

Ei

75  
Azadi Ka  
Amrit Mahotsav



# Competency Focused Practice Questions

Science (Volume 2) | Grade 10



Co-created by

CBSE Centre for Excellence in Assessment  
and  
Educational Initiatives

## PREFACE

Assessments are an important tool that help gauge learning. They provide valuable feedback about the effectiveness of instructional methods; about what students have actually understood and also provide actionable insights. The National Education Policy, 2020 has outlined the importance of competency-based assessments in classrooms as a means to reform curriculum and pedagogical methodologies. The policy emphasizes on the development of higher order skills such as analysis, critical thinking and problem solving through classroom instructions and aligned assessments.

Central Board of Secondary Education (CBSE) has been collaborating with Educational Initiatives (Ei) in the area of assessment. Through resources like the [Essential Concepts document](#) and [A- Question-A-Day \(AQAD\)](#), high quality questions and concepts critical to learning have been shared with schools and teachers.

Continuing with the vision to ensure that every student is learning with understanding, Question Booklets have been created for subjects for Grade 10th and 12th. These booklets contain competency-based items, designed specifically to test conceptual understanding and application of concepts.

### ***Process of creating competency-based items***

All items in these booklets are aligned to the NCERT curriculum and have been created keeping in mind the learning outcomes that are important for students to understand and master. Items are a mix of Free Response Questions (FRQs) and Multiple-Choice Questions (MCQs). In case of MCQs, the options (correct answer and distractors) are specifically created to test for understanding and capturing specific errors/misconceptions that students may harbour. Each incorrect option can thereby inform teachers on specific gaps that may exist in student learning. In case of subjective questions, each question also has a detailed scoring rubric to guide evaluation of students' responses.

Each item has been reviewed by experts, to check for appropriateness of the item, validity of the item, conceptual correctness, language accuracy and other nuances.

### ***How can these item booklets be used?***

There are 187 questions in this booklet.

The purpose of these item booklets is to provide samples of high-quality competency-based items to teachers. The items can be used to–

- get an understanding of what good competency-based questions could look like
- give exposure to students to competency-based items
- assist in classroom teaching and learning
- get inspiration to create more such competency-based items

Students can also use this document to understand different kinds of questions and practice specific concepts and competencies. There will be further additions in the future to provide competency focused questions on all chapters.

The item booklets are aligned with the 2022-23 curriculum. However, a few questions from topic which got rationalized in 2023-24 syllabus are also there in the booklet which may be used as a reference for teachers and students.

*Please write back to us to give your feedback.*

**Team CBSE**

## CONTENTS

1. ACIDS, BASES AND SALTS .....	1
Answer Key & Marking Scheme.....	4
2. CARBON COMPOUNDS .....	6
Answer Key & Marking Scheme.....	7
3. CHEMICAL REACTIONS .....	8
Answer Key & Marking Scheme.....	9
4. CONTROL AND COORDINATION .....	10
Answer Key & Marking Scheme.....	10
5. ELECTRICITY .....	11
Answer Key & Marking Scheme.....	15
6. HEREDITY AND EVOLUTION.....	16
Answer Key & Marking Scheme.....	18
7. HUMAN EYE AND COLOURFUL WORLD .....	19
Answer Key & Marking Scheme.....	20
8. LIFE PROCESSES .....	21
Answer Key & Marking Scheme.....	23
9. METALS AND NON-METALS .....	24
Answer Key & Marking Scheme.....	25
10. OUR ENVIRONMENT .....	26
Answer Key & Marking Scheme.....	26
11. PERIODIC CLASSIFICATION .....	27
Answer Key & Marking Scheme.....	27
12. REFLECTION AND REFRACTION .....	28
Answer Key & Marking.....	28
13. REPRODUCTION .....	29
Answer Key & Marking Scheme.....	31
14. SOURCES OF ENERGY .....	32
Answer Key & Marking Scheme.....	34
15. CHEMICAL SUBSTANCES- NATURE AND BEHAVIOUR.....	35
Answer Key and Marking Scheme .....	42
16. WORLD OF LIVING.....	45
Answer Key and Marking Scheme .....	63
17. NATURAL PHENOMENA .....	74

Answer Key and Marking Scheme .....	78
18. EFFECTS OF CURRENT .....	81
Answer Key and Marking Scheme .....	84
19. NATURAL RESOURCES .....	85
Answer Key and Marking Scheme .....	95

## 1. ACIDS, BASES AND SALTS

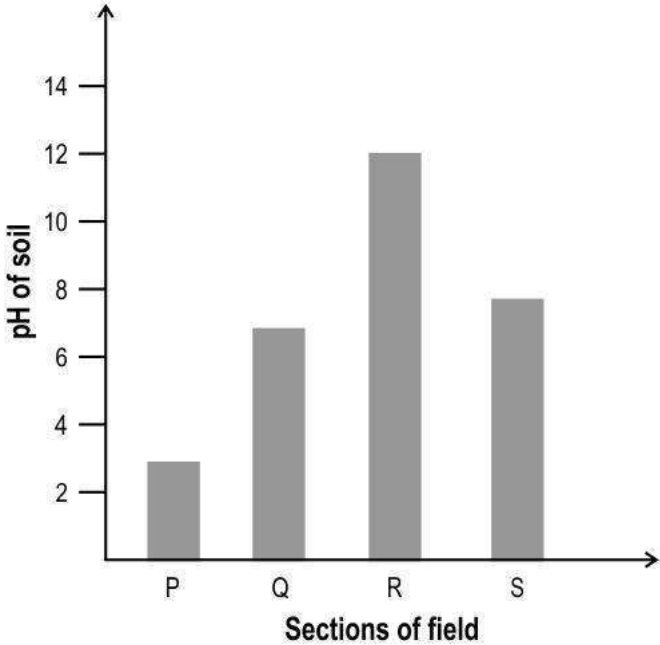
Q. No	Question	Marks															
<b>Multiple Choice Question</b>																	
Q.1	<p>Hydrangea plants develop blue or pink flowers depending on the availability of aluminium from the soil. When the soil is acidic, aluminium is more available to the roots, resulting in blue flowers. When the soil is alkaline, the availability of aluminium decreases, resulting in pink flowers.</p> <p>The graph below is of the pH of the soil at different sections of a field.</p>  <p>In which section of the field will the flowers on ALL the hydrangea plants definitely be blue in colour and in which section will the flowers on ALL the hydrangea plants definitely be pink in colour?</p> <table border="1" data-bbox="400 1644 1190 2011"> <thead> <tr> <th>Option</th> <th>Blue flowers</th> <th>Pink flowers</th> </tr> </thead> <tbody> <tr> <td>W</td> <td>Section P and Q</td> <td>Section R and S</td> </tr> <tr> <td>X</td> <td>Section R and S</td> <td>Section P and Q</td> </tr> <tr> <td>Y</td> <td>Section P, Q and S</td> <td>Section R</td> </tr> <tr> <td>Z</td> <td>Section P</td> <td>Section R</td> </tr> </tbody> </table> <p>A. W</p>	Option	Blue flowers	Pink flowers	W	Section P and Q	Section R and S	X	Section R and S	Section P and Q	Y	Section P, Q and S	Section R	Z	Section P	Section R	1
Option	Blue flowers	Pink flowers															
W	Section P and Q	Section R and S															
X	Section R and S	Section P and Q															
Y	Section P, Q and S	Section R															
Z	Section P	Section R															

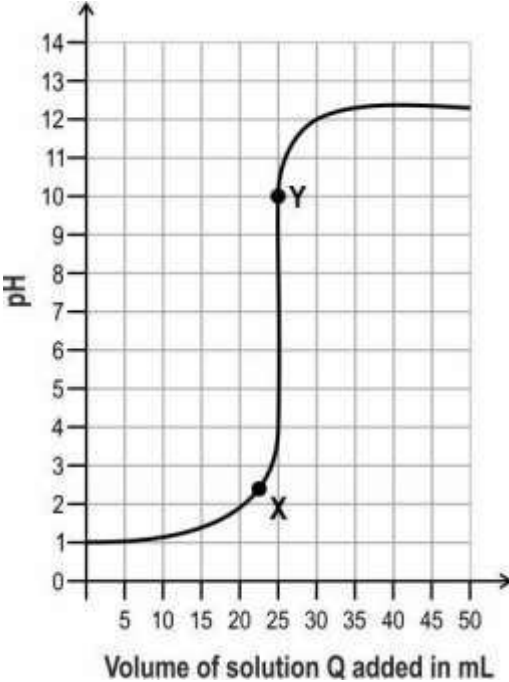
	B. X C. Y D. Z	
<b>Free Response Question/ Subjective Question</b>		
Q.2	An excess of carbon dioxide gas is bubbled through lime water. (a) Will the pH of lime water change? If yes, how? Explain your answer. (b) Write the balanced equation for the reaction.	3
Q.3	Tanu takes 500 mL milk each in two bowls P and Q. She adds curd to both the bowls and baking soda only to bowl Q as shown below. (a) Bowl P - 500 mL milk + 1 teaspoon curd (b) Bowl Q - 500 mL milk + 1 teaspoon curd + 1 teaspoon baking soda In which bowl will the milk form into curd faster? Explain your answer.	3
Q.4	A solution P is taken in a flask and two drops of phenolphthalein indicator is added to it. The graph below shows how the pH of the mixture changes as a solution Q is added dropwise to the flask with stirring. 	3
Q.5	Aditi adds 1 mole of dilute hydrochloric acid to an aqueous solution of 1 mole of sodium carbonate. (a) Write the balanced equation for the reaction that takes place.	5

(b) How will the colour of a red litmus and a blue litmus paper change when dipped in this mixture? Explain why.

Q.6

The presence of acidic gases in the air increases the rate of corrosion. Furthermore, an increase in temperature can also increase the rate of corrosion.

The graph below is created under 4 different conditions (shown below in the table) of temperature and acidic nature of air.

Condition	Temperature (in °C)	pH value
1	20	6
2	30	6
3	30	7
4	20	7

Which of the graphs represents condition 2?

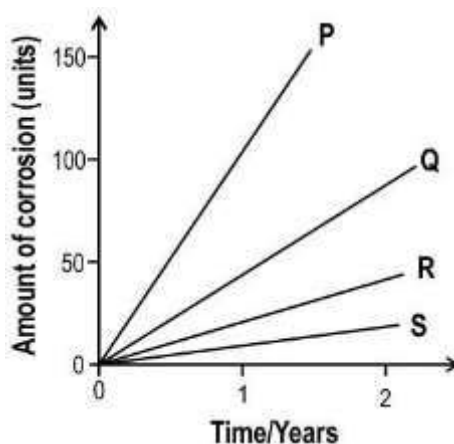

- (a) P
- (b) Q
- (c) R
- (d) S

1

## Answer Key & Marking Scheme

Q. No	Answers	Marks
Q.1	D. Z	1
Q.2	<p>(a)</p> <ul style="list-style-type: none"> <li>- The pH of lime water will decrease. [0.5 marks]</li> <li>- Carbon dioxide, being an acidic oxide, will neutralise lime water which is basic. [1 mark]</li> </ul> <p>OR</p> <ul style="list-style-type: none"> <li>-The products formed, namely, calcium carbonate and Calcium hydrogen carbonate are basic salts but less basic than Calcium hydroxide so pH decreases.</li> </ul> <p>(b) 0.5 marks each for writing the formula of lime water and the product calcium bicarbonate; 0.5 marks for balancing the equation:</p> $\text{Ca(OH)}_2 + 2 \text{CO}_2 \text{ ---> Ca(HCO}_3\text{)}_2$ <p>OR</p> $\text{Ca(OH)}_2 + \text{CO}_2 \text{ ---> CaCO}_3 + \text{H}_2\text{O}$ $\text{CaCO}_3 + \text{CO}_2 + \text{H}_2\text{O ---> Ca(HCO}_3\text{)}_2$	3
Q.3	<p>The milk will form into curd faster in bowl P.</p> <ul style="list-style-type: none"> <li>- Curdling of milk takes place due to formation of lactic acid by bacteria. [1 mark]</li> <li>- In bowl Q, the lactic acid formed by bacteria has to first neutralise the baking soda, which is basic in nature, before the milk starts curdling. [1 mark]</li> </ul>	3
Q.4	<p>(a) 0.5 marks each for the following:</p> <ul style="list-style-type: none"> <li>- solution P: acidic</li> <li>- solution Q: basic</li> </ul> <p>(b) 0.5 marks for each of the following:</p> <ul style="list-style-type: none"> <li>- colour of solution at X: colourless</li> <li>- colour of solution at Y: pink</li> </ul> <p>(c) neutralisation</p>	3
Q.5	<p>(a) 0.5 marks each for writing the formula of each reactant and product:</p> $\text{HCl} + \text{Na}_2\text{CO}_3 \text{ ---> NaCl} + \text{NaHCO}_3$ <p>(b)</p> <ul style="list-style-type: none"> <li>- Red litmus paper will turn blue. [0.5 marks]</li> <li>- There will be no effect on blue litmus paper. [0.5 marks]</li> </ul>	5



	<ul style="list-style-type: none"><li>- The complete neutralisation of 1 mole of sodium carbonate requires 2 moles of hydrochloric acid. [1 mark]</li><li>- Since only 1 mole of HCl is used, neutralisation is incomplete and the mixture will be basic. [1 mark]</li></ul>	
Q.6	Graph P	1

## 2. CARBON COMPOUNDS

Q. No	Question	Marks
<b>Free Response Question/ Subjective Question</b>		
Q.7	<p>Combustion analysis of compound X revealed the ratio of its elements in a molecule to be carbon:hydrogen:oxygen::3:6:2. The compound undergoes esterification to yield an ester and water.</p> <p>(a) Identify the compound X. Write its chemical formula.</p> <p>(b) Write the balanced equation for the combustion of compound X.</p>	2
Q.8	<p>Bonding of oxygen with carbon and with hydrogen are highly exothermic processes. Compare the amount of energy released on combustion of methane and propane.</p> <p>(a) Which compound will yield more energy per mole on combustion? Justify your answer.</p> <p>(b) Write the balanced chemical equations for complete combustion of propane and methane.</p>	3
Q.9	<p>One mole of an alkane P is burned in an excess of oxygen to yield 6 moles of carbon dioxide and 14 moles of water.</p> <p>(a) Write the chemical formula and chemical name of the compound.</p> <p>(b) Will this compound produce a clear or sooty flame on burning? Justify your answer.</p>	3

## Answer Key & Marking Scheme

Q. No	Answers	Marks
Q.7	(a) Propionic acid / Propanoic acid [0.5 marks] C <sub>2</sub> H <sub>5</sub> COOH [0.5 marks] (c) $2\text{C}_2\text{H}_5\text{COOH} + 7\text{O}_2 \rightarrow 6\text{CO}_2 + 6\text{H}_2\text{O} + \text{energy}$	2
Q.8	(a) Energy released per mole will be more in propane since it has more number of carbon atoms. (b) 1 mark for each correct equation: $\text{CH}_4 + 2\text{O}_2 \rightarrow \text{CO}_2 + 2\text{H}_2\text{O}$ $\text{C}_3\text{H}_8 + 5\text{O}_2 \rightarrow 3\text{CO}_2 + 4\text{H}_2\text{O}$	3
Q.9	(a) 1 mark each for the correct name and formula: chemical name - Hexane chemical formula - C <sub>6</sub> H <sub>14</sub> (b) It will burn with a clear flame since it is a saturated hydrocarbon.	3

### 3. CHEMICAL REACTIONS

Q. No	Question	Marks
<b>Free Response Question/ Subjective Question</b>		
Q.10	<p>Photographic film consists of a gelatin emulsion with silver halide grains layered onto a film base. The halides that are used are silver chloride, bromide or iodide. The photographic film is usually stored in metal containers to protect it from light.</p> <p>Write the chemical equation for the possible chemical reaction that this method of storing photographic film is preventing.</p>	1
Q.11	<p>Trupti mixed one teaspoon of baking soda in 500 g of cake mixture. She kept the mixture aside for 5 minutes.</p> <p>Geeta mixed one teaspoon of baking powder in 500 g of the same cake mixture. She also kept the mixture aside for 5 minutes.</p> <p>She then baked the two cakes together in the same oven. Whose cake is likely to rise higher? Justify your answer.</p>	3
Q.12	<p>While cooking in an aluminum vessel, Sudeshna burned some food till all that was left was a completely charred and black residue. She just left the blackened vessel heating on the stove. After an hour she found that the vessel was completely clean, with no trace of any blackness.</p> <p>(a) Write a chemical equation to explain what happened to the charred, black residue that made it disappear.</p> <p>(b) Name the type of reaction referred to in (a).</p>	2

## Answer Key & Marking Scheme

Q. No	Answers	Marks
Q.10	$2\text{AgX} \xrightarrow{\text{Light}} 2\text{Ag} + \text{X}_2$	1
Q.11	<p>Trupti's cake will rise more. [1 mark]</p> <p>Baking powder is a mixture of sodium bicarbonate and tartaric acid. [1 mark]</p> <p>- Baking soda is pure sodium bicarbonate. Hence one teaspoon of baking soda contains more bicarbonate than baking powder and releases more carbon dioxide than baking powder.. [1 marks]</p>	3
Q.12	<p>(a) 0.5 marks each for writing the reactants and product:</p> $\text{C} + \text{O}_2 \rightarrow \text{CO}_2$ <p>(b) 0.5 marks for any of the following:</p> <ul style="list-style-type: none"><li>- combustion</li><li>- oxidation</li><li>- combination</li></ul>	2

## 4. CONTROL AND COORDINATION

Q. No	Question	Marks
<b>Multiple Choice Question</b>		
Q.13	<p>Two statements are given below - one labelled Assertion (A) and the other labelled Reason (R). Read the statements carefully and choose the option that correctly describes statements (A) and (R).</p> <p><i>Assertion (A):</i> All reflex actions are involuntary actions but only some involuntary actions are reflex actions.</p> <p><i>Reason (R):</i> Reflex actions take the shortest route from the receptor (detector of stimulus) to the effector (producer of response).</p> <p>Which of the following is correct?</p> <p>A. Both (A) and (R) are true and (R) is correct explanation of the assertion.</p> <p>B. Both (A) and (R) are true but (R) is not the correct explanation of the assertion.</p> <p>C. (A) is true but (R) is false.</p> <p>D. (A) is false but (R) is true.</p>	1

### Answer Key & Marking Scheme

Q.No	Answers	Marks
Q.13	B. Both (A) and (R) are true but (R) is not the correct explanation of the assertion.	1

## 5. ELECTRICITY

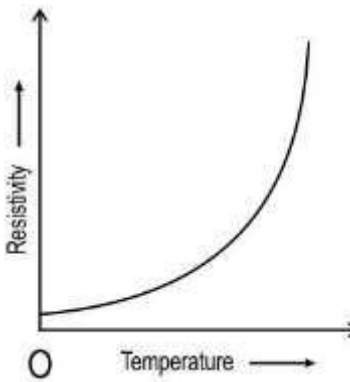
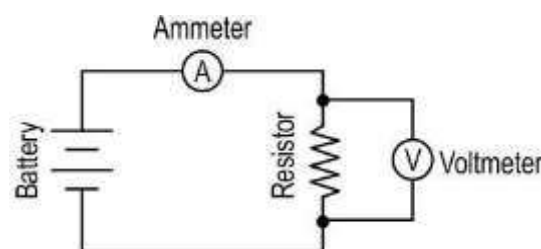
Q. No	Question	Marks
<b>Multiple Choice Question</b>		
Q.14	<p>The graph below shows the variation of resistivity of copper with temperature.</p> <div style="text-align: center;">  </div> <p>Kishore constructs a simple circuit as shown below. The resistor is made of copper.</p> <div style="text-align: center;">  </div> <p>He then heats the copper resistor. What will happen to the current flowing through the circuit? Why?</p> <p>A. The current will increase because the resistance of copper increases with an increase in temperature.</p> <p>B. The current will increase because the resistance of copper decreases with an increase in temperature.</p> <p>C. The current will decrease because the resistance of copper increases with an increase in temperature.</p> <p>D. The current will decrease because the resistance of copper decreases with an increase in temperature.</p>	1
Q.15	Priya has three resistors each of resistance $2\ \Omega$ .	1

	<p>Which of the following resistances will she NOT be able to get by combining these resistors in different combinations?</p> <p>A. <math>0.67 \Omega</math></p> <p>B. <math>0.75 \Omega</math></p> <p>C. <math>3 \Omega</math></p> <p>D. <math>6 \Omega</math></p>																
Q.16	<p>A cylindrical copper wire X of length <math>l</math> and radius <math>r</math> has a resistance <math>R</math> and resistivity <math>\rho</math>. Another copper wire Y has a length <math>2l</math> and a radius <math>2r</math>.</p> <p>Which of the following rows in the table shows the correct resistance and resistivity of the copper wire Y?</p> <table border="1" data-bbox="564 696 1010 1310"> <thead> <tr> <th></th> <th>Resistance</th> <th>Resistivity</th> </tr> </thead> <tbody> <tr> <td>I</td> <td><math>R/2</math></td> <td><math>\rho</math></td> </tr> <tr> <td>II</td> <td><math>R</math></td> <td><math>\rho</math></td> </tr> <tr> <td>III</td> <td><math>R/2</math></td> <td><math>\rho/2</math></td> </tr> <tr> <td>IV</td> <td><math>R</math></td> <td><math>\rho/2</math></td> </tr> </tbody> </table> <p>A. I</p> <p>B. II</p> <p>C. III</p> <p>D. IV</p>		Resistance	Resistivity	I	$R/2$	$\rho$	II	$R$	$\rho$	III	$R/2$	$\rho/2$	IV	$R$	$\rho/2$	1
	Resistance	Resistivity															
I	$R/2$	$\rho$															
II	$R$	$\rho$															
III	$R/2$	$\rho/2$															
IV	$R$	$\rho/2$															
Q.17	<p>The variable resistor <math>R</math> is connected in a circuit, as shown below. A variable resistor is one whose resistance can be changed.</p>	1															



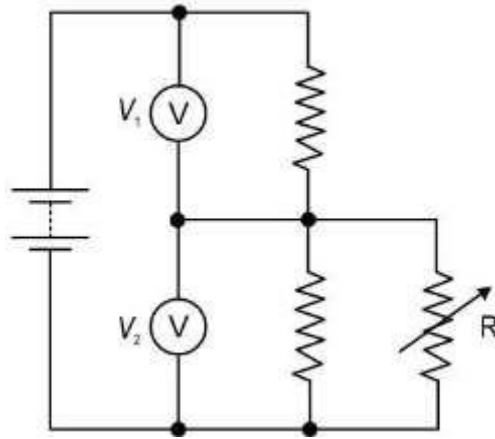

The resistance of  $R$  is increased. What will happen to the voltmeter readings  $V_1$  and  $V_2$ ?

- A.  $V_1$  increases;  $V_2$  increases
- B.  $V_1$  increases;  $V_2$  decreases
- C.  $V_1$  decreases;  $V_2$  increases
- D.  $V_1$  decreases;  $V_2$  decreases

Q.18

Kishore connects two resistors in parallel. He wants to measure the total current through the two resistors.

1

Which of the following shows the correct arrangement to measure the current through Ammeter 'A'?

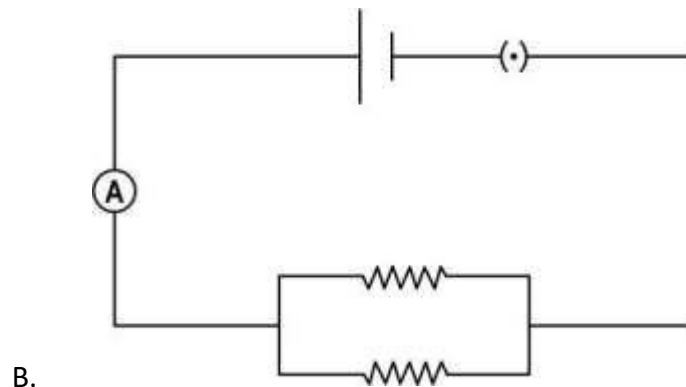
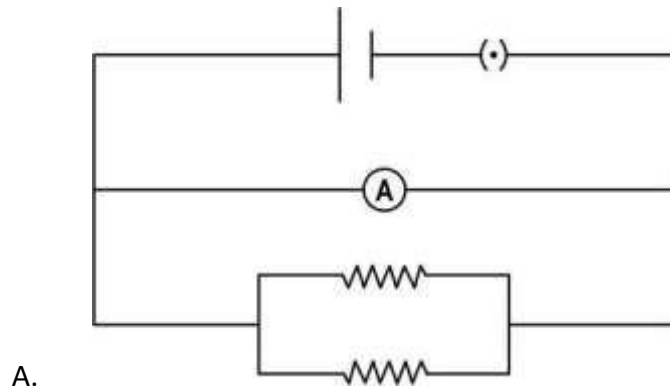

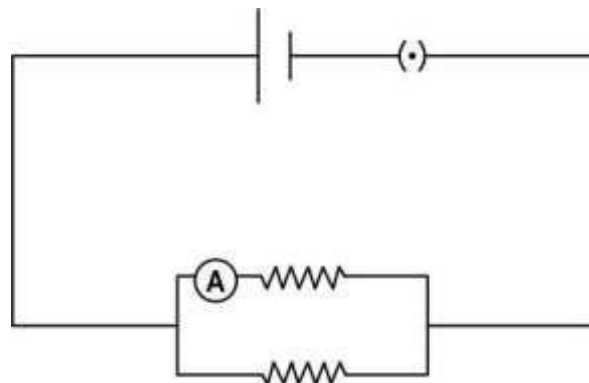

C.

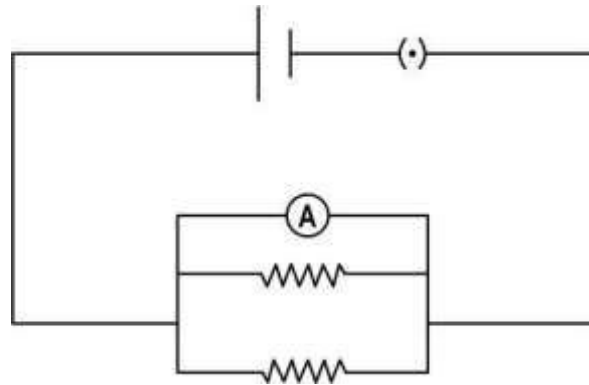

D.

## Answer Key & Marking Scheme

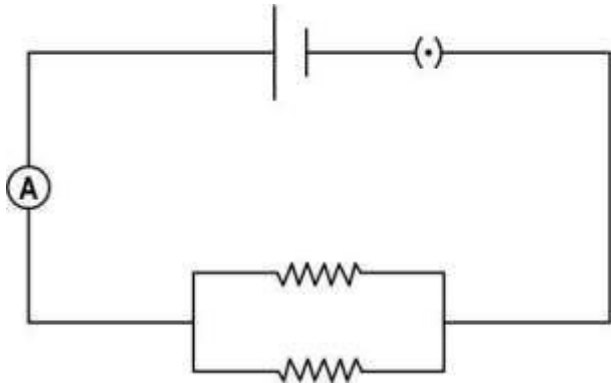
Q. No	Answers	Marks
Q.14	C. The current will decrease because the resistance of copper increases with an increase in temperature.	1
Q.15	B. $0.75 \Omega$	1
Q.16	A. I	1
Q.17	C. $V_1$ decreases; $V_2$ increases	1
Q.18	<p>B.</p>  A circuit diagram showing a battery at the top with a voltmeter connected across it. An ammeter labeled 'A' is on the left vertical wire. The bottom horizontal wire branches into two parallel resistors, which then recombine on the right vertical wire.	1

## 6. HEREDITY AND EVOLUTION

Q. No	Question	Marks
<b>Multiple Choice Question</b>		
Q.19	<p>Manisha is an Indian actress. She was born in Delhi to a homemaker mother and an engineer father. She is around 5 feet tall. She has naturally curly hair. She has trained in contemporary and ballet dancing.</p> <p>Which of these is MOST LIKELY to be true about her children?</p> <p>A. They may dance well.</p> <p>B. They may grow up to have curly hair.</p> <p>C. They may be born to an engineer father.</p> <p>D. They may become famous actors one day.</p>	1
Q.20	<p>Study the diagrams given below that depict the analogy/homology of organs and answer the questions that follow.</p> <div style="text-align: center;"> <p style="text-align: center;">P    Q</p> </div> <p>Which diagram represents evolution of homologous organs?</p> <p>A. only P</p> <p>B. only Q</p> <p>C. both - P and Q</p> <p>D. neither - P nor Q</p>	1
<b>Free Response Question/ Subjective Question</b>		
Q.21	<p>The farmer concludes that the allele for green seeds shows dominance over that of yellow seeds.</p> <p>Is he right? Justify your answer.</p>	1
Q.22	<p>What is the genetic basis of the increase in number of the black peppered moth after the Industrial Revolution?</p>	1
Q.23	<p>The picture below is of the chromosome pairs present in a cell of a person.</p>	2

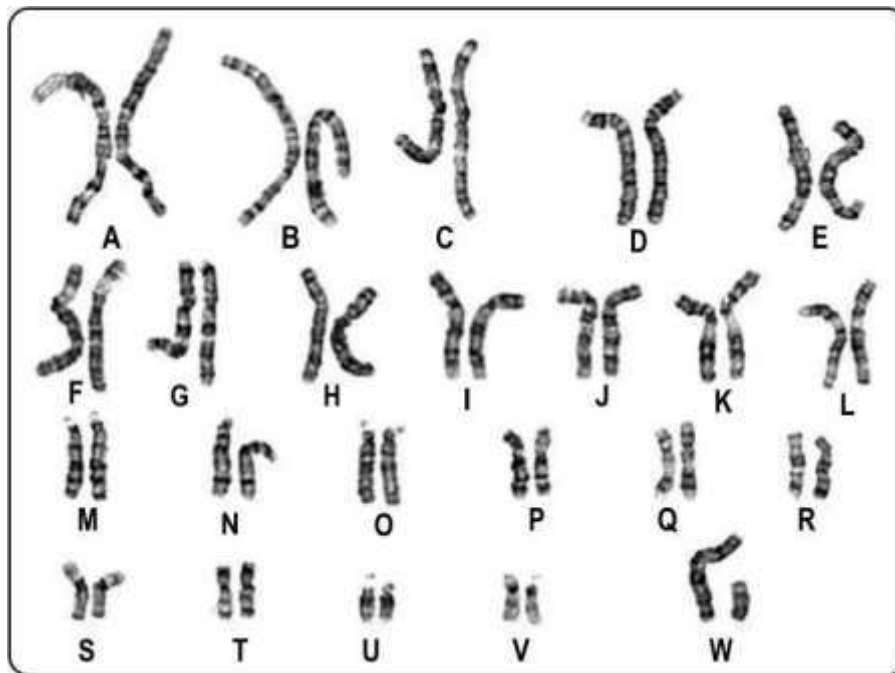

- (a) Identify the sex of the person. Give reasons for your answer.
- (b) State the number of chromosomes present in a male or female gamete.

## Answer Key & Marking Scheme

Q. No	Answers	Marks
Q.19	B. They may grow up to have curly hair.	1
Q.20	A. only P	1
Q.21	Yes, he is right. [0.5 marks] Since the offspring pod has all green seeds, the allele for green seeds is dominant even if present in heterozygous state. [0.5 marks]	1
Q.22	During sexual reproduction, the genes determining darker colour of moths get selected and their frequency increased in the population.	1
Q.23	(a) male. 23rd pair has X and Y chromosomes. (b) 23	2

## 7. HUMAN EYE AND COLOURFUL WORLD

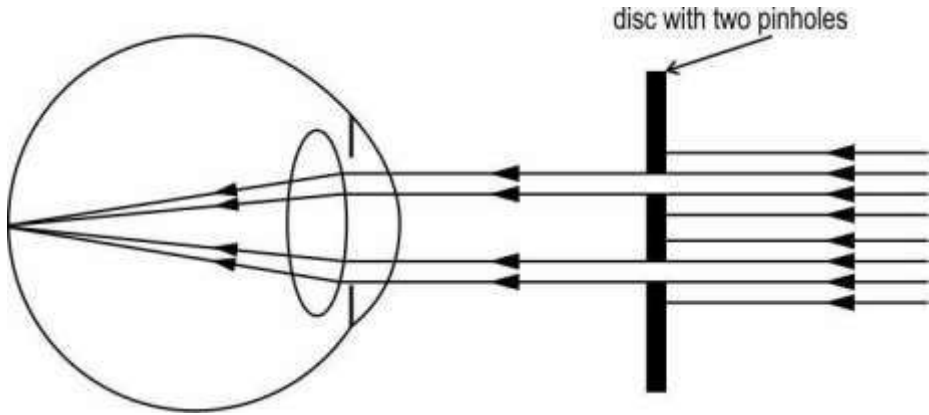
Q. No	Question	Marks
<b>Free Response Question/ Subjective Question</b>		
Q.24	<p>An autorefractor, which is used to automatically measure the refractive errors in a person's eye, makes use of the Scheiner principle explained below.</p> <p>Parallel rays of light from a distant object are limited to two parallel bundles of light using a disc with two pinholes. For an eye with no refractive error, the rays would be focused on the retina, where only one spot can be observed.</p>  <p>(a) For a myopic eye, how many spots will be observed on the retina?</p> <p>(b) Draw a diagram showing how the light rays fall on the retina of a myopic eye?</p> <p>(c) What could be the reason for the observation?</p>	3

## Answer Key & Marking Scheme

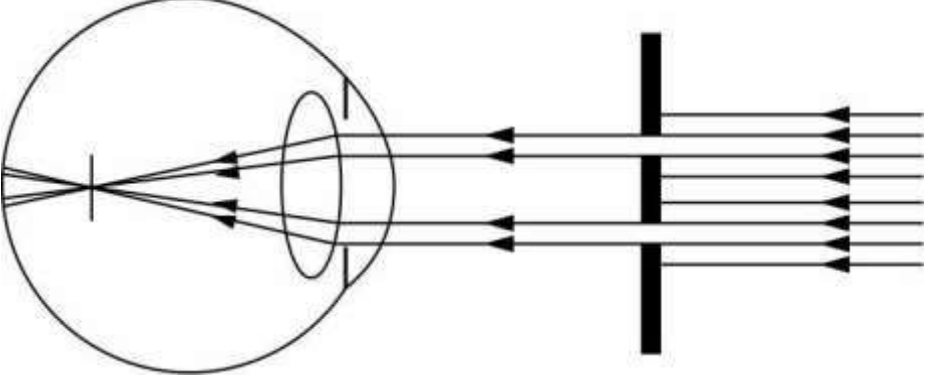
Q. No	Answers	Marks
Q.24	<p>(a) 2 spots</p> <p>(b)</p>  <p>(c) 1 mark for any one of the following:</p> <ul style="list-style-type: none"><li>-elongation of the eyeball</li><li>-excessive curvature of the eye lens</li></ul>	3



## 8. LIFE PROCESSES

Q. No	Question	Marks
<b>Multiple Choice Question</b>		
	<p>Answer the questions based on the following information.</p> <p>William Harvey (1578–1657) was one of the early biologists who studied the bodies of humans and animals. He even dissected the bodies and did experiments with the heart and blood vessels. He concluded from his experiments that the blood leaves the heart through the arteries and returns via the veins. However, he could not explain how blood left the arteries to enter the veins. He said there must be some structure between arteries and veins but he could not find them. Marcello Malphigi (1628–1694) later discovered these structures while studying a dead frog's lungs under a microscope.</p>	1
Q.25	<p>Which of the following structures did Malphigi find in the frog?</p> <p>A. cells</p> <p>B. capillaries</p> <p>C. heart chambers</p> <p>D. small air sacs in lungs</p>	1
Q.26	<p>What is the MOST LIKELY reason why Harvey could NOT find these structures?</p> <p>A. These structures are not found in humans.</p> <p>B. These structures are found only in the lungs.</p> <p>C. These structures become visible only in dead animals.</p> <p>D. These structures were too small to be seen by the naked eye.</p>	1
Q.27	<p>Which of the following statements about arteries and veins is TRUE?</p> <p>A. Arteries have thicker walls than veins.</p> <p>B. Veins have thicker walls than arteries.</p> <p>C. All arteries carry only oxygenated blood.</p> <p>D. All veins carry only deoxygenated blood.</p>	1
Q.28	<p>Which two chambers of the human heart have arteries connected to them?</p> <p>A. left atrium and left ventricle</p> <p>B. right atrium and right ventricle</p> <p>C. left atrium and right atrium</p>	1

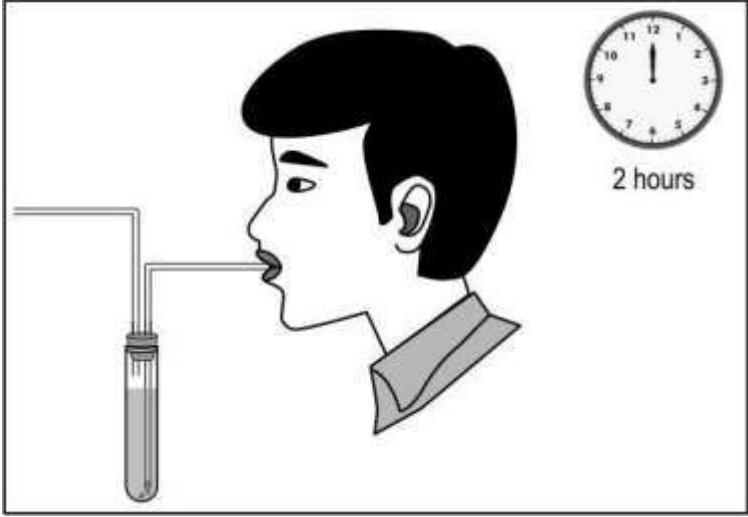
	D. left ventricle and right ventricle	
	<b>Free Response Question/ Subjective Question</b>	
Q.29	<p>Aerobic respiration requires intake of oxygen to breakdown food to release energy.</p> <p>(a) Name the structures through which gaseous exchange takes place in plants and human beings.</p> <p>(b) Name the structure that controls the size of the chest cavity in humans to facilitate exchange of gases.</p> <p>(c) What is the process by which gas exchange occurs in plants?</p> <p>(d) Why is the process named in (c) not sufficient to carry oxygen throughout human body? How is this complemented in humans to ensure that oxygen is carried to all parts of the body?</p> <p>(e) Reactions in living systems can absorb heat or release heat. State whether the heat energy is absorbed/ released during digestion. Also write the scientific term to denote the same.</p>	5
Q.30	<p>Given below is an image of an experiment conducted by a student to understand the process of respiration. He blows into a clear solution present in the test tube and sees that it turns cloudy.</p> <div style="text-align: center;">  </div> <p>(a) What is the most likely substance present in the test tube?</p> <p>(b) What could be the aim of his experiment?</p> <p>(c) What kind of respiration is shown in the experiment? Justify your answer.</p>	3

## Answer Key & Marking Scheme

Q. No	Answers	Marks
Q.25	B. capillaries	1
Q.26	D. These structures were too small to be seen by the naked eye.	1
Q.27	A. Arteries have thicker walls than veins.	1
Q.28	D. left ventricle and right ventricle	1
Q.29	<p>(a) 0.5 marks for each correct answer:  Plants: stomata/guard cells  Human beings: alveoli/ lungs</p> <p>(b) diaphragm</p> <p>(c) diffusion</p> <p>(d) 1 mark for each correct point:  - because diffusion is a slow process and human beings have complex tissues that might not allow diffusion to happen effectively and easily  - carried by the blood/ haemoglobin in the blood</p> <p>(e) 0.5 marks for each correct answer:  - use up heat  - endothermic</p>	5
Q.30	<p>(a) lime water / dilute aqueous solution of calcium hydroxide/ <math>\text{Ca}(\text{OH})_2</math></p> <p>(b) To prove that carbon dioxide is released during respiration.</p> <p>(c) - aerobic respiration [0.5 marks]  - <math>\text{CO}_2</math> is a product of either aerobic respiration or fermentation [0.5 marks]  - fermentation does not take place in human cells. [0.5 marks]</p>	3

## 9. METALS AND NON-METALS

Q. No	Question	Marks
<b>Multiple Choice Question</b>		
Q.31	<p>In which of the following forms do electrovalent compounds conduct electricity?</p> <p>A. only in solid form</p> <p>B. both in solid form and in aqueous solution</p> <p>C. both in aqueous solution and in molten form</p> <p>D. in solid form, molten form and in aqueous solution</p>	1
<b>Free Response Question/ Subjective Question</b>		
Q.32	<div style="text-align: center;"> </div> <p>Many chemical reactions like the one shown below, are carried out in glass-lined, iron chemical reactors instead of directly in iron reactors.</p> $\text{CH}_3\text{COOH} + \text{CH}_3\text{CH}_2\text{OH} \xrightarrow{\text{Sulphuric acid}} \text{CH}_3\text{COOCH}_2\text{CH}_3$ <p>State one advantage of carrying out the reaction in a glass-lined reactor instead of directly in an iron reactor.</p>	1

## Answer Key & Marking Scheme

Q. No	Answers	Marks
Q.31	C. both in aqueous solution and in molten form	1
Q.32	1 mark for any one of the following: - no corrosion of the reactor - no contamination of the product with metal / metal salts	1

## 10. OUR ENVIRONMENT

Q. No	Question	Marks						
<b>Free Response Question/ Subjective Question</b>								
Q.33	<p>Fishes like swordfish and king mackerel are tertiary consumers. Fishes like tilapia and salmon are secondary consumers. The habitat of these fishes are usually contaminated with heavy metals like mercury.</p> <p>Scientists suggest consuming these fishes according to the table given below:</p> <table border="1" style="margin-left: auto; margin-right: auto;"> <thead> <tr> <th>Best to avoid (1 serving/ month)</th> <th>Good to eat (2-3 servings/week)</th> </tr> </thead> <tbody> <tr> <td>King mackerel</td> <td>Tilapia</td> </tr> <tr> <td>Swordfish</td> <td>Pollock</td> </tr> </tbody> </table> <p>What phenomenon is likely to have led the scientists to give such an advisory to the people who consume fish?</p>	Best to avoid (1 serving/ month)	Good to eat (2-3 servings/week)	King mackerel	Tilapia	Swordfish	Pollock	1
Best to avoid (1 serving/ month)	Good to eat (2-3 servings/week)							
King mackerel	Tilapia							
Swordfish	Pollock							

### Answer Key & Marking Scheme

Q. No	Answers	Marks
Q.33	biomagnification of toxic substances in higher trophic levels	1

## 11. PERIODIC CLASSIFICATION

Q. No	Question	Marks
<b>Multiple Choice Question</b>		
Q.34	<p>Elements X and Y are in the same period of the periodic table and have the same valency. The force of attraction between the valence electrons and the nucleus is greater in element X than in element Y.</p> <p>Which of the following is also likely to be true about elements X and Y?</p> <p>A. Y is more electronegative than X.</p> <p>B. X has a greater atomic radius than Y.</p> <p>C. Y has more metallic character than X.</p> <p>D. X forms covalent bonds and Y forms ionic bonds.</p>	1

### Answer Key & Marking Scheme

Q. No	Answers	Marks
Q.34	C. Y has more metallic character than X.	1

## 12. REFLECTION AND REFRACTION

Q. No	Question	Marks
<b>Multiple Choice Question</b>		
Q.35	Which of the following characteristics of a spherical mirror is given by the ratio of the size of the image to the size of the object? A. aperture B. magnification C. focal length D. radius of curvature	1
Q.36	Which of the following does the negative sign in the power -3D signify? A. The focus is on the same side of the lens as the object. B. The focus is on the opposite side of the lens as the object. C. The principal focus is situated outside the principal axis. D. The focal length on one side of the lens is smaller than that on the other.	1
Q.37	Which among the two lenses with power- 3D AND 4D respectively can form a real image? A. only the lens with power -3 D B. only the lens with power 4 D C. both the lenses D. neither of the lenses	1

### Answer Key & Marking

Q.No	Answers	Marks
Q.35	B. magnification	1
Q.36	A. The focus is on the same side of the lens as the object.	1
Q.37	B. only the lens with power 4 D	1



## 13. REPRODUCTION

Q. No	Question	Marks
<b>Multiple Choice Question</b>		
Q.38	<p>Contraceptives help in preventing pregnancies.</p> <p>What function would a contraceptive loop inserted at T serve?</p> <p>A. Stopping sperms from reaching and fertilizing eggs</p> <p>B. Stopping release of sperms</p> <p>C. Blocking the release of eggs</p> <p>D. Stopping egg creation</p>	1
<b>Free Response Question/ Subjective Question</b>		
Q.39	<p>Bindu wants to produce a hybrid variety of tomatoes. She has tomato plants X and Y belonging to two different varieties, one with smooth, long fruits and the other one with wrinkled, round fruits.</p> <p>Tomatoes have bisexual flowers. Bindu carries out the following steps carefully to cross pollinate the flowers of plants X and Y:</p> <ol style="list-style-type: none"> <li>1. She removes a part of the flowers of tomato plant X just before the flowers bloom.</li> <li>2. She manually pollinates the flowers of tomato plant X using pollen from the flowers of tomato plant Y.</li> <li>3. She ties small plastic bags around the pollinated flowers of tomato plant X. The plastic bags are removed after a couple of days.</li> </ol> <p>What could be reason for covering the pollinated flowers of plant X?</p>	1
Q.40	<p>Water hyacinths reproduce both sexually and asexually. They reproduce sexually by producing seeds through flowers, and asexually by bud formation or fragmentation. It undergoes reproduction through either of the methods depending on environmental conditions. Water hyacinths bloom freely in water-rich conditions whereas, reproduction for survival is more effort-intensive in water-scarce conditions.</p> <p>(a) Explain why this variation in reproduction is required in water hyacinths.</p> <p>(b) Which mode of reproduction is likely to occur in the following conditions? Justify:</p>	4

	(i) abundance of water (ii) scarcity of water	
Q.41	<p>Compare the reproductive parts of flowers and humans and answer the questions below:</p> <p>(a) Which part of the human female reproductive system has a similar function as the stigma in a flower? Give a reason to support your answer.</p> <p>(b) Testes in the male reproductive system would correspond to which part of the male reproductive system in a flower? Justify.</p> <p>(c) The style of a flower and the fallopian tube in humans correspond functionally with each other. Is this statement true? Justify your answer.</p>	3

## Answer Key & Marking Scheme

Q. No	Answers	Marks
Q.38	A. Stopping sperms from reaching and fertilizing eggs	1
Q.39	to prevent pollen from other plants from reaching the stigma	1
Q.40	<p>(a) 1 mark for each point:</p> <ul style="list-style-type: none"> <li>- The population of each species thrives in its specific habitat/niche, having particular environmental conditions which can change due to reasons beyond the organisms' control</li> <li>- Having variation ensures greater chances of survival through such changes.</li> </ul> <p><i>[Accept any other valid answer]</i></p> <p>(b) 0.5 marks each for the following points:</p> <p>(i)</p> <ul style="list-style-type: none"> <li>- asexual reproduction</li> <li>- In its natural environment, the organism is likely to undergo an energy-efficient method of reproduction such as asexual reproduction.</li> </ul> <p>(ii)</p> <ul style="list-style-type: none"> <li>- sexual reproduction</li> <li>- In a stressed environment, the organism is likely to opt for the effort-intensive method for survival.</li> </ul> <p><i>[Accept any other valid answer]</i></p>	4
Q.41	<p>(a) 0.5 marks for identifying the part and 0.5 marks for the reason:</p> <ul style="list-style-type: none"> <li>- Part - Cervix/Vagina</li> <li>- Reason - The stigma of the flower serves as the point of entry of the male gametes/pollen grains, similarly, the cervix serves as the point of entry of the male gametes/sperm in humans/ vagina receives the male gametes in humans.</li> </ul> <p>(b) 0.5 marks for identifying the part and 0.5 marks for the reason:</p> <ul style="list-style-type: none"> <li>- Part - anther</li> <li>- Function - produces male gametes in form of pollen, just like testes which produce sperms</li> </ul> <p>(c) 0.5 for stating true/false and 0.5 marks for the reason:</p> <ul style="list-style-type: none"> <li>- False</li> <li>- Reason - the main function of the fallopian tube is to serve as the point of fertilisation, which is not the function of the style in flowers.</li> </ul> <p><i>[Accept any other valid answer]</i></p>	3

## 14. SOURCES OF ENERGY

Q. No	Question	Marks
<b>Multiple Choice Question</b>		
Q.42	<p>Place X is a metropolitan city with many high-rise buildings and parks. Place Y is an elevated location with cottages and large open spaces.</p> <p>Which of the two places would be LESS SUITABLE to set up a wind energy farm and why?</p> <p>A. Place X, as there are parks.</p> <p>B. Place Y, as it is at an elevation.</p> <p>C. Place Y, as it has large open spaces.</p> <p>D. Place X, as there are high-rise buildings.</p>	1
Q.43	<p>Mohan owns a large livestock farm near a pond. The farm is on an elevation. It receives a steady wind speed of 10 km/h. The area is sunny for the greater part of the day on most days.</p> <p>Which of the following could be the sources of energy on his farm?</p> <p>P) hydro-electricity</p> <p>Q) biomass</p> <p>R) wind</p> <p>S) solar</p> <p>A. only P and S</p> <p>B. only Q and S</p> <p>C. only Q and R</p> <p>D. only P and R</p>	1
Q.44	<p>The best source of energy to power satellites in space is solar energy.</p> <p>Select the reasons that justify the above statement.</p> <p>P) It is easily available.</p> <p>Q) It is the only inexhaustible form of energy.</p> <p>R) It does not need to be transported as a source of fuel.</p> <p>A. only P and Q</p> <p>B. only Q and R</p> <p>C. only P and R</p>	1

	D. all- P, Q and R	
<b>Free Response Question/ Subjective Question</b>		
Q.45	<p>Although wind is present everywhere, wind energy devices are not commonly found in residential areas.</p> <p>State any TWO reasons why harnessing wind energy is NOT a common practice in residential areas.</p>	2
Q.46	<p>Hydropower plants are used to generate electricity, commonly, from waterfalls.</p> <p>In the absence of waterfalls,</p> <p>(a) What kind of setup has to be made to enable a flowing water source to generate electricity?</p> <p>(b) How does the setup mentioned in (a) help to generate electricity?</p>	2
Q.47	<p>A region 'X' along the coast, with large vacant space experiences a wind speed of 32 km/h for most of the year.</p> <p>(a) Describe, briefly, the setup and the process involved in generating electricity using the given wind speed.</p> <p>(b) State TWO factors that make region X a suitable location to set up a wind energy farm.</p> <p>(c) Apart from wind energy, identify TWO forms of energy that can be generated using renewable sources in region X. Justify your answer.</p>	5

## Answer Key & Marking Scheme

Q. No	Answers	Marks
Q.42	D. Place X, as there are high-rise buildings.	1
Q.43	B. only Q and S	1
Q.44	C. only P and R	1
Q.45	<p>1 mark each for any two reasons such as:</p> <ul style="list-style-type: none"> <li>- Devices that harness wind energy require large areas of land which is generally scarce in residential areas.</li> <li>- Buildings in residential areas may block the wind reducing its speed to below 15 m/s required to run a turbine.</li> </ul> <p>(Accept any other valid answer.)</p>	2
Q.46	<p>(a) High-rise dams can be constructed on the river to obstruct the flow and collect water in the reservoirs.</p> <p>(b) Water falling from the high level of the reservoir turns the turbines at the bottom of the dam, converting the potential energy of the falling water into electricity.</p>	2
Q.47	<p>(a) 0.5 marks for each of the following:</p> <ul style="list-style-type: none"> <li>- A wind energy farm OR windmill has to be set up in the open space available near the coast.</li> <li>- The kinetic energy of the wind causes the windmill to rotate.</li> <li>- The rotating windmill turns the turbine of an electric generator thereby generating electricity.</li> </ul> <p>(b) 1 mark for each of the following:</p> <ul style="list-style-type: none"> <li>- High wind speed that can be used to harness more energy.</li> <li>- availability of large open spaces to set up a windmill/ wind energy farm</li> </ul> <p>(c) 0.5 marks each for identifying the two forms of energy and 0.5 marks for the justification:</p> <ul style="list-style-type: none"> <li>- wave energy</li> <li>- tidal energy</li> <li>- Justification: Since the region is located along the coast, it allows for the generation of electricity using tides and wave speed/size of marine water.</li> </ul>	5

## 15. CHEMICAL SUBSTANCES- NATURE AND BEHAVIOUR

Q. No	Question	Marks										
<b>Multiple Choice Question</b>												
Q.48	<p>Manav found an unknown solid substance on a riverbank. To check its nature, he carried out some tests on the substance and recorded his observations in the table shown below.</p> <table border="1" style="margin-left: auto; margin-right: auto;"> <tbody> <tr> <td style="background-color: #cccccc;"></td> <td style="background-color: #cccccc;"></td> </tr> <tr> <td>Effect of heat</td> <td>melts on heating</td> </tr> <tr> <td>Ductility</td> <td>can be stretched into a thin strand</td> </tr> <tr> <td>Malleability</td> <td>can be beaten into a thin sheet</td> </tr> <tr> <td>Electrical conductivity</td> <td>does not conduct electricity</td> </tr> </tbody> </table> <p>Which of the following could the substance be?</p> <p>A. It is a polymer.            B. It is a metal.            C. It is glass.            D. It is wax.</p>			Effect of heat	melts on heating	Ductility	can be stretched into a thin strand	Malleability	can be beaten into a thin sheet	Electrical conductivity	does not conduct electricity	1
Effect of heat	melts on heating											
Ductility	can be stretched into a thin strand											
Malleability	can be beaten into a thin sheet											
Electrical conductivity	does not conduct electricity											
Q.49	<p>Trupti has given the following reasons for Gold being the most abundantly used metal for jewellery:</p> <p>(i) It has high ductility.            (ii) It has high malleability.            (iii) It shines more than other metals.            (iv) It reacts quickly with oxygen to form a protective layer of oxide.            (v) It does not react with water &amp; oxygen even at high temperatures.</p> <p>Which of the reasons given is/are INCORRECT?</p> <p>A. only (iii)            B. only (iv)            C. only (iv) &amp; (v)            D. only (i), (ii) &amp; (iii)</p>	1										

Q.50	<p>Sheetal has two test tubes, one containing dilute hydrochloric acid and the other dilute sulphuric acid but they are not labelled.</p> <p>Adding which of the following to the test tubes will help her to find out which test tube contains hydrochloric acid and which contains sulphuric acid?</p> <p>A. Blue litmus paper B. Zinc metal strips C. Sodium carbonate D. Barium carbonate</p>	1
Q.51	<p>Two statements are given - one labelled Assertion (A) and the other labelled Reason (R). Read the statements carefully and choose the option that correctly describes statements A and R.</p> <p>Assertion (A): An alloy may be a compound consisting of a metal and a non-metal.</p> <p>Reason (R): An alloy is made by melting a metal and then dissolving other elements in it in definite proportions.</p> <p>A. Both A and R are true and R is the correct explanation for A. B. Both A and R are true but R is not the correct explanation for A. C. A is true but R is false. D. A is false but R is true.</p>	1
Q.52	<p>Freshly cut pieces of iron are stored in three closed containers P, Q and R containing dry air, oxygen and nitrogen respectively.</p> <p>In which of the containers is the Iron likely to rust?</p> <p>A. Only P B. Only P and Q C. All - P, Q and R D. In none of them</p>	1
Q.53	<p>Gautam has to courier a sample of silver bromide powder to a laboratory for analysis.</p> <p>Which of the following containers can he use to pack the sample?</p> <p>P) Transparent glass bottle Q) Opaque plastic bottle R) Black paper packet</p> <p>A. Only P B. Only P or Q</p>	1



	<p>C. Only Q or R D. Any of P, Q or R</p>																					
Q.54	<p>Two statements are given - one labelled Assertion (A) and the other labelled Reason (R). Read the statements carefully and choose the option that correctly describes statements A and R.</p> <p>Assertion (A): Potassium metal burns and produces a flame when thrown in water..</p> <p>Reason (R): The reaction of potassium with water is highly exothermic and violent.</p> <p>A. Both A and R are true and R is the correct explanation for A. B. Both A and R are true but R is not the correct explanation for A. C. A is true but R is false. D. A is false but R is true.</p>	1																				
Q.55	<p>Doing which of the following will break the bonds in a crystal of sodium chloride?</p> <p>A. Passing an electric current through it B. Crushing it into a fine powder C. Mixing it with kerosene D. Mixing it with water</p>	1																				
Q.56	<p>In the list given below, a metal to the right is more reactive than a metal that is to its left.</p> <table border="1" style="margin-left: auto; margin-right: auto;"> <tr> <td>Copper</td> <td>Tin</td> <td>Nickel</td> <td>Cobalt</td> <td>Iron</td> <td>Zinc</td> </tr> </table> <p>The table below gives the colour of the metal sulphate salt solutions.</p> <table border="1" style="margin-left: auto; margin-right: auto;"> <thead> <tr> <th>Metal salt solution</th> <th>Colour of aqueous metal salt solution</th> </tr> </thead> <tbody> <tr> <td>Copper sulphate</td> <td>blue</td> </tr> <tr> <td>Tin sulphate</td> <td>yellow</td> </tr> <tr> <td>Nickel sulphate</td> <td>green</td> </tr> <tr> <td>Cobalt sulphate</td> <td>pink</td> </tr> <tr> <td>Iron sulphate</td> <td>green</td> </tr> <tr> <td>Zinc sulphate</td> <td>colourless</td> </tr> </tbody> </table>	Copper	Tin	Nickel	Cobalt	Iron	Zinc	Metal salt solution	Colour of aqueous metal salt solution	Copper sulphate	blue	Tin sulphate	yellow	Nickel sulphate	green	Cobalt sulphate	pink	Iron sulphate	green	Zinc sulphate	colourless	1
Copper	Tin	Nickel	Cobalt	Iron	Zinc																	
Metal salt solution	Colour of aqueous metal salt solution																					
Copper sulphate	blue																					
Tin sulphate	yellow																					
Nickel sulphate	green																					
Cobalt sulphate	pink																					
Iron sulphate	green																					
Zinc sulphate	colourless																					

	<p>Adding nickel and iron metal to which of the following solutions will show that iron is more reactive than nickel?</p> <p>A. Copper sulphate B. Tin sulphate C. Cobalt sulphate D. Zinc sulphate</p>	
Q.57	<p>Carbon compounds undergo combustion in oxygen to give carbon dioxide along with heat and light.</p> <p>The same number of molecules of each of the following carbon compounds undergo complete combustion.</p> <p>P) CH<sub>3</sub>COOH Q) CH<sub>3</sub>CH<sub>2</sub>COOH R) CH<sub>3</sub>CH=CH<sub>2</sub> S) CH<sub>3</sub>CH<sub>2</sub>CH<sub>2</sub>OH</p> <p>Which of them will produce the same amount of carbon dioxide?</p> <p>A. Only P and Q B. Only Q and S C. Only P, Q and R D. Only Q, R and S</p>	1
<b>Free response question/Subjective Question</b>		
Q.58	<p>A redox reaction is defined as a type of chemical reaction that involves transfer of electrons between reacting atoms, molecules or ions - one gains and the other loses electrons.</p> <p>Study the equation given below that shows the reaction between zinc oxide and hydrochloric acid.</p> $\text{ZnO} + 2 \text{HCl} \rightarrow \text{ZnCl}_2 + \text{H}_2\text{O}$ <p>(a) Is this a double displacement reaction? Justify your answer. (b) Is this a redox reaction? Justify your answer. (c) Name another type of reaction that this is an example of.</p>	4
Q.59	<p>A metal oxide XO on being heated with carbon does NOT produce carbon dioxide.</p>	1

	Give a possible explanation for this behaviour of the metal oxide.													
Q.60	Farida checks the pH of a bottle of milk at 10:00 AM and finds it to be 6.0. She leaves the milk bottle on the table at room temperature (30 °C). She checks the pH of the milk again at 4:00 PM.  How is the pH of the milk at 4:00 PM likely to compare with the pH of milk at 10:00 AM? Justify your answer.	2												
Q.61	On opening a bottle of soda, Nishchal observed that there was a lot of effervescence and some of the soda water bubbled out of the bottle.  (a) Write the equation for the chemical reaction taking place.  (b) Identify the type of reaction.	2												
Q.62	The molecular formulae of three carbon compounds are:  CH <sub>2</sub> O, C <sub>2</sub> H <sub>4</sub> O, C <sub>3</sub> H <sub>6</sub> O  (a) Identify the compound that can exist as two isomers having different functional groups.  (b) Write the structures of the two isomers.	2												
Q.63	Uzma peeled and cut some potatoes and left them in an open bowl. After a few minutes, she observed that the cut potato pieces had turned brown.  Radhika also peeled and cut some potatoes. She kept the cut potato pieces immersed in a bowl of water. The potato pieces in water did NOT turn brown.  Explain the difference in the reaction of the cut potato pieces in the two cases.	1												
Q.64	The densities of water and magnesium metal at different temperatures are given in the table below.  <table border="1" data-bbox="343 1400 1252 1803"> <thead> <tr> <th>Temperature</th> <th>Density of magnesium metal</th> <th>Density of water</th> </tr> </thead> <tbody> <tr> <td>25 °C (room temperature)</td> <td>1.738</td> <td>0.99</td> </tr> <tr> <td>100 °C (boiling point of water)</td> <td>-</td> <td>0.958</td> </tr> <tr> <td>650 °C (melting point of magnesium)</td> <td>1.64</td> <td>-</td> </tr> </tbody> </table> 'Magnesium floats in boiling water because its density decreases on heating.'  Is the statement above true or false? If true, give a reason. If false, correct it.	Temperature	Density of magnesium metal	Density of water	25 °C (room temperature)	1.738	0.99	100 °C (boiling point of water)	-	0.958	650 °C (melting point of magnesium)	1.64	-	1
Temperature	Density of magnesium metal	Density of water												
25 °C (room temperature)	1.738	0.99												
100 °C (boiling point of water)	-	0.958												
650 °C (melting point of magnesium)	1.64	-												
Q.65	Bala was monitoring the pH of the reaction mixture of ethanoic acid and ethanol in the presence of an acid.	2												

	What change is he likely to observe in the pH of the mixture as the reaction proceeds? Explain why.	
Q.66	A red litmus paper and a blue litmus paper are added to distilled water in a test tube. A small piece of calcium metal is now added to the water.  What will be the change in the colour of the litmus papers? Justify your answer.	2
Q.67	Sugar free chewing gum, as shown below, have baking soda as one of their key ingredients and are considered to be good to keep teeth healthy.   <p style="text-align: center;">Chewing gum</p> What is likely to be the function of baking soda in the chewing gum?	1
Q.68	Study the compounds displayed below:  <div style="display: flex; justify-content: space-around; align-items: center;"> <div style="text-align: center;"> <math display="block">\begin{array}{c} \text{H} \quad \text{H} \\   \quad   \\ \text{C} = \text{C} \\   \quad   \\ \text{H} \quad \text{H} \end{array}</math> <p><b>A</b></p> </div> <div style="text-align: center;"> <math display="block">\begin{array}{c} \text{H} \quad \text{H} \\   \quad   \\ \text{H}-\text{C}-\text{C}-\text{H} \\   \quad   \\ \text{H} \quad \text{H} \end{array}</math> <p><b>B</b></p> </div> <div style="text-align: center;"> <math display="block">\begin{array}{c} \text{H} \quad \text{H} \\   \quad   \\ \text{H}-\text{C}-\text{C}-\text{O}-\text{H} \\   \quad   \\ \text{H} \quad \text{H} \end{array}</math> <p><b>C</b></p> </div> </div> <div style="display: flex; justify-content: space-around; align-items: center;"> <div style="text-align: center;"> <math display="block">\begin{array}{c} \text{H} \\   \\ \text{H}-\text{C}-\text{H} \\   \\ \text{H} \end{array}</math> <p><b>D</b></p> </div> <div style="text-align: center;"> <math display="block">\begin{array}{c} \text{O} \\    \\ \text{H}-\text{C}-\text{O}-\text{H} \end{array}</math> <p><b>E</b></p> </div> <div style="text-align: center;"> <math display="block">\begin{array}{c} \text{H} \quad \text{H} \quad \text{H} \\   \quad   \quad   \\ \text{C} = \text{C} - \text{C} - \text{H} \\   \quad \quad   \\ \text{H} \quad \quad \text{H} \end{array}</math> <p><b>F</b></p> </div> </div> <p>(a) Identify all the compounds that are the first members of their respective homologous series.</p> <p>(b) Which of the above compounds are likely to undergo non-catalytic hydrogenation reaction?</p> <p>(c) Which TWO compounds will combine to form an ester? Justify with an equation for the reaction.</p>	4
Q.69	The reactants of two reactions are given below.	3

	<p>1) <math>\text{Ca} + 2 \text{H}_2\text{O} \rightarrow</math></p> <p>2) <math>\text{CaO} + \text{H}_2\text{O} \rightarrow</math></p> <p>(a) Write the chemical formula of the common product formed in the two reactions.</p> <p>(b) Identify the type of reaction that will occur in (1) and (2)</p>																					
Q.70	<p>Excess carbon dioxide gas is continuously bubbled through a solution of slaked lime.</p> <p>(a) Describe how the appearance of the solution will change.</p> <p>(b) Write balanced chemical equations to explain the change described in the answer to part (a). Also mention the states of the reactants and products for each reaction.</p>	5																				
Q.71	<p>The list given here is known as the Electrochemical Series of metals. A metal to the right is more reactive than a metal that is to its left in the list.</p> <table border="1" style="margin-left: auto; margin-right: auto;"> <tbody> <tr> <td>Copper</td> <td>Tin</td> <td>Nickel</td> <td>Cobalt</td> <td>Iron</td> <td>Zinc</td> </tr> </tbody> </table> <p>The table below gives the colour of a few metal sulphate salt solutions.</p> <table border="1" style="margin-left: auto; margin-right: auto;"> <tbody> <tr> <td></td> <td></td> </tr> <tr> <td>Copper sulphate</td> <td>blue</td> </tr> <tr> <td>Tin sulphate</td> <td>yellow</td> </tr> <tr> <td>Nickel sulphate</td> <td>green</td> </tr> <tr> <td>Cobalt sulphate</td> <td>pink</td> </tr> <tr> <td>Iron sulphate</td> <td>green</td> </tr> <tr> <td>Zinc sulphate</td> <td>colourless</td> </tr> </tbody> </table> <p>To show that iron is more reactive than nickel, Smita adds nickel metal and iron metal to copper sulphate solution in separate test tubes.</p> <p>Will her test show which is more reactive? Justify your answer.</p>	Copper	Tin	Nickel	Cobalt	Iron	Zinc			Copper sulphate	blue	Tin sulphate	yellow	Nickel sulphate	green	Cobalt sulphate	pink	Iron sulphate	green	Zinc sulphate	colourless	2
Copper	Tin	Nickel	Cobalt	Iron	Zinc																	
Copper sulphate	blue																					
Tin sulphate	yellow																					
Nickel sulphate	green																					
Cobalt sulphate	pink																					
Iron sulphate	green																					
Zinc sulphate	colourless																					
Q.72	<p>To compare the reactivity of magnesium and aluminium two friends carried out the following tests.</p> <ul style="list-style-type: none"> <li>- Shardul reacted the metals with hydrochloric acid.</li> <li>- Ashwin reacted the metals with boiling water.</li> </ul> <p>Whose test will differentiate between the two metals based on their reactivity? Explain why.</p>	3																				

## Answer Key and Marking Scheme

Q.No	Answers	Marks
Q.48	A. It is a polymer.	1
Q.49	B. Only (iv)	1
Q.50	D. Barium carbonate	1
Q.51	D. A is false but R is true.	1
Q.52	D. (in none of them)	1
Q.53	C. Only Q or R	1
Q.54	D. A is false but R is true.	1
Q.55	D. mixing it with water	1
Q.56	C. Cobalt sulphate	1
Q.57	D. Only Q, R and S	1
Q.58	(a) Yes, it is. [0.5 marks] Since there is an exchange of ions between the reactants. [1 mark] (No marks to be given if justification not given.) (b) No, it is not. [0.5 marks] Since none of the reactants have gained or lost an electron. [1 mark] (No marks to be given if justification not given.) (c) neutralisation reaction	4
Q.59	(a) The metal is more reactive than carbon.	1
Q.60	- The pH will be below 6.0. [1 mark] - The bacteria in the milk will change the lactose in the milk to lactic acid. [1 mark] (no marks to be given without justification.)	2
Q.61	(a) $\text{H}_2\text{CO}_3 \rightarrow \text{H}_2\text{O} + \text{CO}_2$ (b) decomposition reaction	2
Q.62	(a) $\text{C}_3\text{H}_6\text{O}$ (b) $\text{CH}_3 - \text{CO} - \text{CH}_3$ [0.5 marks]  $\text{CH}_3 - \text{CH}_2 - \text{CHO}$ [0.5 marks]	2

Q.63	The browning of the potato pieces kept in the open bowl is likely to be due to an oxidation reaction between the potato and air. The oxidation is prevented by keeping the potato under water as it is not in contact with air.	1
Q.64	- False. - Magnesium floats when placed in boiling water because of the bubbles of hydrogen gas forming on its surface as it reacts with hot water.	1
Q.65	- He will observe an increase in the pH of the reaction mixture. [1 mark] - The amount of acid in the reaction mixture keeps decreasing as ethanoic acid gets converted to the ester. [1 mark]	2
Q.66	- The red litmus paper will turn blue. [0.5 marks] - The blue litmus paper will remain blue. [0.5 marks] - Calcium reacts with water to form calcium hydroxide which is basic in nature. [1 mark] (no marks to be given if justification is not given or is incorrect)	2
Q.67	The baking soda neutralises the acids that form in the plaque between the teeth.	1
Q.68	(a) A,D,E (1 mark for all three correct answers, 0.5 marks for any two correct answers.) (b) 0.5 marks each for both correct names: compound A and compound F (c) compound E and compound C [0.5 marks each] $\text{HCOOH} + \text{CH}_3\text{CH}_2\text{OH} \rightarrow \text{CH}_3\text{CH}_2\text{COOH} + \text{H}_2\text{O}$ [1 mark]	4
Q.69	(a) $\text{Ca}(\text{OH})_2$ (b) 1 mark each for the following: - (1) displacement reaction - (2) combination reaction (Accept any other correct answer.)	3
Q.70	(a) The clear solution of slaked lime will first turn milky (whitish in colour), due to the formation of a precipitate of calcium carbonate. [1 mark] On passing excess carbon dioxide, the solution will slowly become clear again due to formation of calcium bicarbonate which is water soluble. [1 mark] (b) 1 mark for each balanced equation, and 0.5 marks for writing the states of the substances in each equation. $\text{Ca}(\text{OH})_2(\text{aq}) + \text{CO}_2(\text{g}) \rightarrow \text{CaCO}_3(\text{s}) + \text{H}_2\text{O}(\text{l})$ [1.5 marks] $\text{CaCO}_3(\text{s}) + \text{H}_2\text{O}(\text{l}) + \text{CO}_2(\text{g}) \rightarrow \text{Ca}(\text{HCO}_3)_2(\text{aq})$ [1.5 marks]	5

Q.71	<p>The test will not be able to tell which is more reactive.</p> <p>Both nickel and iron are more reactive than copper and will displace copper from the copper sulphate solution turning it green in colour.</p>	2
Q.72	<p>Only Ashwin's test</p> <p>1 mark each for the following:</p> <ul style="list-style-type: none"> <li>- Only magnesium reacts with boiling water releasing hydrogen gas. Aluminium does not react with boiling water, but reacts only with steam. [1 mark]</li> </ul> <p><math>\text{Mg} + 2 \text{H}_2\text{O} (\text{l}) \rightarrow \text{Mg}(\text{OH})_2 + \text{H}_2</math></p> <p><math>\text{Al} + \text{H}_2\text{O} (\text{l}) \rightarrow \text{no reaction}</math></p> <ul style="list-style-type: none"> <li>- Both magnesium and aluminium react with hydrochloric acid producing salt and hydrogen gas. [1 mark]</li> </ul> <p><math>\text{Mg} + 2 \text{HCl} \rightarrow \text{MgCl}_2 + \text{H}_2</math></p> <p><math>2 \text{Al} + 6 \text{HCl} \rightarrow 2 \text{AlCl}_3 + 3 \text{H}_2</math></p>	3

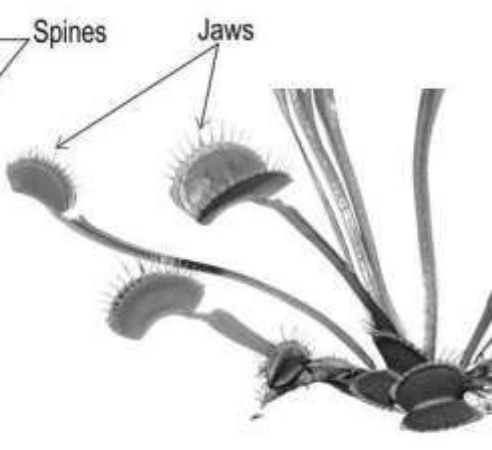

## 16. WORLD OF LIVING

Q.No	Question	Marks
<b>Multiple Choice Question</b>		
Q.73	<p>Study the diagrams given below that depict the analogy/homology of organs and answer the question that follow.</p> <div style="display: flex; justify-content: space-around; align-items: center;"> <div data-bbox="288 577 718 795" style="text-align: center;"> <p>Leaf ———→</p> <p style="margin-left: 40px;">Modify to climb a support → Tendril in pea</p> <p style="margin-left: 40px;">Modify to provide protection → Spine in Barberry</p> <p><b>P</b></p> </div> <div data-bbox="750 604 1308 795" style="text-align: center;"> <p>Leaf in pea ———→</p> <p style="margin-left: 40px;">Adapt to climb a support → Tendril in pea. Tendril in cucurbits</p> <p style="margin-left: 40px;">Stem in cucurbits ———→</p> <p><b>Q</b></p> </div> </div> <p>In cactus, leaves are modified into spines. In Venus flytrap, leaves are modified into jaws.</p> <div style="display: flex; justify-content: space-around; align-items: center; text-align: center;"> <div data-bbox="383 929 702 1433">  <p><b>Cactus</b></p> </div> <div data-bbox="734 929 1228 1433">  <p><b>Venus flytrap</b></p> </div> </div> <p>Which diagram are the spines in the cactus and the jaws in the venus flytrap an example of?</p> <p>A. Only P            B. Only Q            C. Both - P and Q            D. Neither - P nor Q</p>	1
Q.74	<p>Which of the following would be true about the wings of a bat and wings of a bird?</p> <p>A. They are analogous organs with same functions.            B. They are analogous organs with different function.            C. They are homologous organs with same function.</p>	1

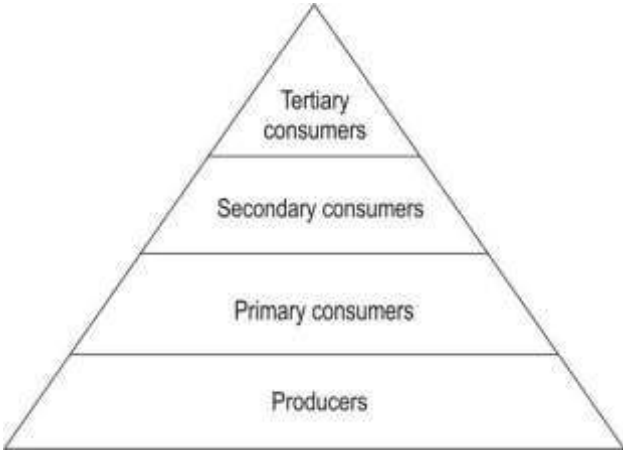
	D. They are homologous organs with different functions.	
Q.75	<p>Two statements are given - one labelled Assertion (A) and the other labelled Reason (R). Read the statements carefully and choose the option that correctly describes statements A and R.</p> <p>Assertion (A): Desert plants take in carbon dioxide for photosynthesis during the night.</p> <p>Reason (R): In desert plants, the stomata are closed during the day to conserve water by reducing transpiration.</p> <p>A. Both A and R are true and R is the correct explanation of A.  B. Both A and R are true but R is not the correct explanation of A.  C. A is true but R is false.  D. A is false but R is true</p>	1
Q.76	<p>Given below are some biotic and abiotic components of an ecosystem.</p> <p>rock, rainfall, sunlight, mango tree, rabbit</p> <p>Which of these components can continue to exist in the absence of the other component/s?</p> <p>A. Only sunlight  B. Only rock and sunlight  C. Only mango tree and rabbit  D. Only rock, sunlight and rainfall</p>	1
Q.77	<p>Shown below are the trophic levels of an ecosystem.</p>  <p>In which of the levels can an omnivore be present?</p> <p>A. Only secondary consumers  B. Only secondary and tertiary consumers  C. Only primary and secondary consumers</p>	1

	D. Only primary, secondary and tertiary consumers	
Q.78	<p>If the total energy at the trophic level of producers in an ecosystem is 'E', then which of the following corresponds to the energy available to the tertiary consumers?</p> <p>A. <math>E/10</math>  B. <math>10 \times E</math>  C. <math>E/1000</math>  D. <math>1000 \times E</math></p>	1
Q.79	<p>Two statements are given - one labelled Assertion (A) and the other labelled Reason (R).</p> <p>Assertion (A): Plants that can reproduce asexually cannot reproduce sexually.</p> <p>Reason (R): Asexual reproduction does not involve the production of gametes.</p> <p>Which of the following correctly describes statements A and R?</p> <p>A. (A) and (R) are true and (R) is the reason for (A).  B. (A) and (R) are true, but (R) is not the reason for (A).  C. (A) is false, but (R) is true  D. (A) is true, but (R) is false.</p>	1
Q.80	<p>Biological magnification is the increase in concentration of certain substances in the tissues of organisms at successively higher levels in a food chain.</p> <p>Which of the following could the increase be a result of?</p> <p>P) Inability of environmental processes to break down the substance.  Q) High rate of excretion of the substance by the organism.  R) Low rate of internal degradation of the substance by organisms.</p> <p>A. Only P  B. Only P and R  C. Only Q and R  D. All - P, Q and R</p>	1
Q.81	<p>Two statements are given below - one labelled Assertion (A) and the other labelled Reason (R).</p> <p>Assertion (A): Blood cells do not receive or pass information to the rest of the human body.</p> <p>Reason (R): Blood cells are not directly connected with neurons.</p>	1

	<p>Which of the following is CORRECT?</p> <p>A. Both A and R are true, and R is the correct explanation for A.  B. Both A and R are true, but R is not the correct explanation for A.  C. A is true, but R is false.  D. A is false, but R is true.</p>	
Q.82	<p>If a tall pea plant bearing red flowers (TTRr) is crossed with another pea plant that is short and has white flowers (ttrr), what percentage of GAMETES will have both alleles for short and white flowers?</p> <p>A. 0%  B. 25%  C. 50%  D. 75%</p>	1
	<p>Rett syndrome is a condition caused due to the mutation of a gene located on the X chromosome such that if an individual carries even a check of the mutated gene they show symptoms of the condition.</p> <p>Consider two cases:  Case I: The father is affected (<math>X^R Y</math>) but the mother is not (XX).  Case II: The father is not affected (XY) but the mother is (<math>X^R X</math>).</p> <p>Answer Q.83 and Q.84 based on the facts given above.</p>	
Q.83	<p>What is the probability of the sons showing symptoms of the disease in Case I?</p> <p>A. 0%  B. 50%  C. 75%  D. 100%</p>	1
Q.84	<p>What percentage of daughters will be affected in Case II?</p> <p>A. 0%  B. 25%  C. 50%  D. 100%</p>	1
Q.85	<p>A person views an object placed at a certain distance from him. Under which of the following scenarios will the ciliary muscles contract to make the eye lens thicker?</p> <p>A. Amount of light falling on the object is increased  B. Amount of light falling on the object is decreased  C. Object is moved closer to the eye</p>	1

	D. Object is moved away from the eye	
Q.86	<p>Which of the following is/are TRUE about traits that have NOT been naturally selected?</p> <p>X) They were always detrimental to the life of the organism.</p> <p>Y) Their frequency reduces in subsequent generations.</p> <p>Z) Organisms carrying these traits cannot reproduce at all.</p> <p>A. Only X B. Only Y C. Only Y and Z D. Only X and Z</p>	1
Q.87	<p>Gautam notices that Geeta wears spectacles that contain concave lens. Which of the following conditions could she be suffering from?</p> <p>A. Myopia B. Hypermetropia C. Presbyopia D. Night blindness</p>	1
Q.88	<p>In their natural habitats, and in normal conditions, in which of the following organisms does the offspring exhibit genetic differences from their parents?</p> <p>A. Cyanobacteria B. Amoeba C. Planaria D. Ant</p>	1
Q.89	<p>Two statements are given below - one labelled Assertion (A) and the other labelled Reason (R).</p> <p>Assertion (A): An organism with 24 chromosomes undergoes binary fission to give rise to daughter cells with 12 chromosomes each.</p> <p>Reason (R): Binary fission gives rise to two identical daughter cells.</p> <p>Which of the following is correct?</p> <p>A. Both A and R are true, and R is the correct explanation for A. B. Both A and R are true, but R is not the correct explanation for A. C. A is true, but R is false D. A is false, but R is true.</p>	1
Q.90	Which of the following actions helps the eye in focusing on distant objects?	1

	<p>A. Pupil dilation          B. Thickening of the eye lens          C. Relaxation of the ciliary muscles          D. Contraction of the ciliary muscles</p>	
Q.91	<p>A certain class of herbicides does not allow pollen tube formation. Which of the following processes does it inhibit?</p> <p>A. Cross-pollination          B. Self-pollination          C. Seed dispersal          D. Fertilisation</p>	1
	<p>Study the diagrams given below that depict the analogy/homology of organs and answer the question that follow.</p> <div style="display: flex; justify-content: space-around; align-items: center;"> <div style="text-align: center;"> <p><b>P</b></p> </div> <div style="text-align: center;"> <p><b>Q</b></p> </div> </div>	
Q.92	<p>Sweet potato is a root that stores food. Potato is a stem that stores food.</p> <p>Which diagram(s) is/are the example/s above related to?</p> <p>A. Only P          B. Only Q          C. Both - P and Q          D. Neither - P nor Q</p>	1
Q.93	<p>Here is an image of a pea plant climber. The tendrils at the tip of the plant tend to circle around an object or a surface.</p> <div style="text-align: center;"> </div> <p>When are tendrils likely to grow rapidly?</p>	1

	<p>A. When the plant is kept warm          B. When the plant is well watered          C. When the tendril is exposed to light          D. When the tendril is in contact with a surface</p>	
Q.94	<p>Pneumatophores are a special type of root found in mangrove trees. They help the trees by absorbing oxygen needed for the process of respiration in the roots.</p>  <p>Choose the statement/s that is/are TRUE about the movement exhibited by pneumatophores.</p> <p>P) They show negative geotropism as they grow against gravity.          Q) They show positive phototropism to absorb sunlight.          R) They show positive geotropism as the roots grow below the ground.</p> <p>A. Only P          B. Only Q          C. Both P &amp; Q          D. Both Q &amp; R</p>	1
Q.95	<p>Identify the example that BEST describes a response to a stimulus.</p> <p>A. Absorption of sunlight by chloroplast          B. Germination of pollen grains on the stigma          C. Absorption of nutrients from the soil through root hairs          D. Transportation of water and nutrients through the xylem</p>	1
Q.96	<p>Person X met with an accident and injured a part of the hindbrain.</p> <p>Identify the function that is most likely to be affected due to the injury.</p> <p>A. Display of emotions          B. Walking in a straight line          C. Regulation of blood pressure          D. Maintenance of body temperature</p>	1

Q.97	<p>A plant 'X' is placed in a closed box and is left unwatered for 15 days.</p> <p>Identify the plant hormone that is MOST LIKELY to be released and the reason for it.</p> <p>A. Auxins are released in response to the absence of light.          B. Cytokinins are released to enhance the growth of the shoot.          C. Abscisic acid is released in response to the scarcity of water.          D. Gibberellins are produced in response to the absence of water.</p>	1
<b>Free response question/Subjective Question</b>		
Q.98	<p>There are different nutrients required by the human body. These are in 3 major categories of carbohydrates, fats and proteins (apart from vitamins, minerals and roughage).</p> <p>(a) Digestion of nutrient R happens in the stomach. Identify R.</p> <p>(b) Consider fats and oils from your diet as large globules in your digestive tract. Name the reaction that can help in making these easier to absorb.</p> <p>(c) What is the difference in the kind of medium required for digestive enzymes in the stomach and the small intestine to work?</p>	3
Q.99	<p>In a population of 10,000 ladybugs spread over the entire country, there are 7500 red-colored with black spots, 1200 purple-colored with black spots, and remaining are white-colored with black spots.</p> <p>Which colored ladybugs have an evolutionary advantage? Why?</p>	2
	<p>Bindu wants to produce a hybrid variety of tomatoes. She has tomato plants X and Y belonging to two different varieties, one with smooth, long fruits and the other one with wrinkled, round fruits.</p> <p>Tomatoes have bisexual flowers. Bindu carries out the following steps carefully to cross pollinate the flowers of plants X and Y:</p> <ol style="list-style-type: none"> <li>1. She removes a part of the flowers of tomato plant X just before the flowers bloom.</li> <li>2. She manually pollinates the flowers of tomato plant X using pollen from the flowers of tomato plant Y.</li> <li>3. She ties small plastic bags around the pollinated flowers of tomato plant X. The plastic bags are removed after a couple of days.</li> </ol>	
Q.100	<p>Bindu now wants to try producing a hybrid variety of pumpkins from two varieties P and Q. Pumpkin plants have unisexual flowers, with both male and female flowers on all plants.</p> <p>There is a slight variation in the procedure as described below:</p> <p>- She does NOT remove any part from the pumpkin flowers she wants to pollinate.</p>	2

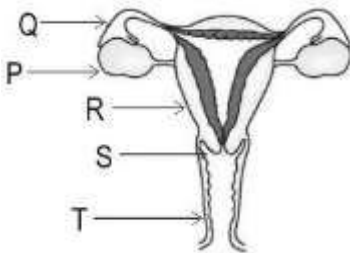

	<p>- However, she still ties small plastic bags around the manually pollinated flowers.</p> <p>Explain why Bindu does not remove any part from the flowers to be pollinated, but still ties small plastic bags after pollination.</p>	
Q.101	<p>Read the two statements below.</p> <p>(P) Adrenaline is also called the fight or flight hormone.</p> <p>(Q) Adrenaline affects the heart to increase heart rate for optimum delivery of oxygen to muscles.</p> <p>Does statement (Q) offer a valid explanation for statement (P)? Justify your answer.</p>	1
Q.102	<p>Human systems work in coordination with each other.</p> <p>Pratik spent an hour in the swimming pool and found himself breathing heavily.</p> <p>(a) Name the:</p> <p>(i) system/s that help his body regain normalcy</p> <p>(ii) system/s that help the systems mentioned in (a-i) to function</p> <p>(b) What can happen to the composition of Pratik's blood if the system/s mentioned in (a-i) does/do not respond properly?</p>	2
Q.103	<p>Vasectomy is a method of contraception in males where the vasa deferentia are tied or sealed so as to prevent sperm from entering the urethra.</p> <p>The diagram below represents the human female reproductive system with some of its parts marked P, Q, R, S, T.</p> <div style="text-align: center;">  </div> <p>(a) Identify the labelled part that will be operated on for 'tubectomy' in females. State its function.</p> <p>(b) Kavya says that if part R is removed the female would not be able to produce eggs. Is she correct? Justify.</p>	3
Q.104	<p>A new sugarcane plant is genetically the same as the parent plant, but a child of human parents is genetically not the same as its parents. Explain why.</p>	2
Q.105	<p>Cyanobacteria, also known as blue-green algae, are a group of photosynthetic bacteria that can fix atmospheric nitrogen and thrive in diverse habitats. They</p>	3

have the ability to produce large amounts of biomass and accumulate lipids suitable for biofuel production.

Shown below are two boxes, X and Y. Containers with water that contains cyanobacteria are placed in both boxes.

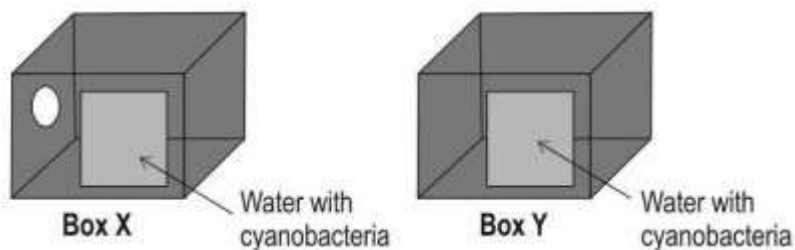

(a) Ideally, how should the samples of water with cyanobacteria be kept in order to get products that can be used for maximum production of biofuels?

(b) In which of the boxes, is cyanobacteria likely to have better growth and why?

Q.106

Hormones in Animals are secreted in specific quantities by glands in the body. The secretion of these hormones is also regulated by the body.

3

(a) The table below gives the normal reading of blood glucose levels before and after eating.

Before eating	After eating
80-100	170-200

Ram's blood glucose level is 275. Name the hormone that would be released to regulate the blood glucose level.

(b) Explain the regulation of the hormone named in answer (a) in TWO points.

Q.107

The stimulus of touch triggers different responses in different plants.

4

A blue pea plant is kept in a well-lit area. The shoot tip curls around the support while growing.



(a) The curling of the shoot tip is in response to touch, not sunlight. Describe an experiment to prove this statement.

	(b) Explain the steps by which the Venus flytrap plant traps insects.	
Q.108	<p>Nitu and Ria went for a routine health check. The doctor tapped the patellar tendon that is below the kneecap. Nitu showed a knee-jerk reaction but Ria didn't show any reaction.</p> <p>(a) What does the lack of reaction in Ria indicate?</p> <p>(b) If Ria sees a sharp object and does not step on it, what kind of action is it? Describe the neural path followed for this action.</p> <p>(c) Write TWO points explaining the neural pathway followed for the knee-jerk reaction in Nitu.</p>	4
Q.109	<p>Here is a conversation between Ria and Lipa:</p> <p>Ria: The sky appears blue as the blue light scatters the most.</p> <p>Lipa: The sky is blue because it reflects the blue of the seas and oceans.</p> <p>Who is correct? Justify your answer.</p>	2
Q.110	<p>Roopa conducts an experiment with light. She notices that when light rays fall on the surface of a certain object, the light rays change direction. When the light leaves the object from another surface, the light rays bend again.</p> <p>(a) What could be the object that Roopa used to conduct this experiment?</p> <p>(b) Why does the light bend twice? Explain with two points.</p>	3
Q.111	<p>Tina was star gazing. She observed celestial objects P and Q. They were visible brightly in the night sky. She concluded that one was a star and the other was a planet.</p> <p>(a) What could she have observed to arrive at her conclusion?</p> <p>(b) If these celestial objects P and Q were to be observed from the moon, would Tina be able to distinguish them as a star and a planet? Why or Why not?</p>	3
Q.112	<p>Nia looked at an object X that was kept near her. She could see it clearly. She then looked at object Y which was kept farther away. She could see object Y also clearly.</p> <p>(a) Which part of the eye enables a person to see clearly, both, objects that are near and those that are far away? Why?</p> <p>(b) Describe the eye changes that enable nearby objects to be seen clearly.</p> <p>(c) Describe the eye changes that enable far-away objects to be seen clearly.</p>	3
Q.113	The figures P and Q show the state of the heart at stages of the cardiac cycle.	2

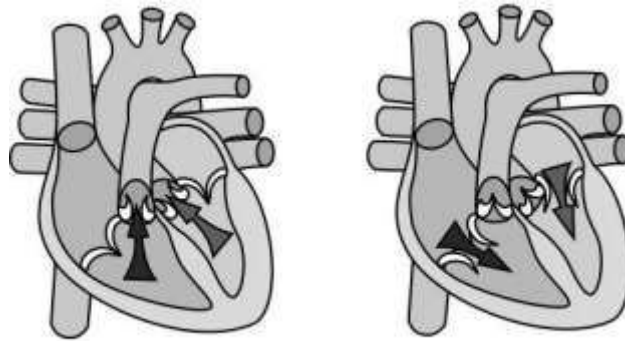

Figure P

Figure Q

Identify the blood pressure values that will be obtained at the stages of the heart, shown in figures P and Q, for a normal person at rest.

Q.114 In the digestive tract, food is moved forward by the rhythmic contraction of muscles lining the tract. This process is called peristalsis.  
List ALL the parts of the digestive tract in which peristalsis occurs.

3

Q.115 In most adults, the left atrium is separated from the right atrium by a septum (wall) to prevent the oxygen-rich blood in the left atrium from mixing with the blood containing a higher amount of carbon dioxide in the right atrium. The patent foramen ovale (PFO) is a hole in the septum separating the left and right atria (upper chambers) of the heart. This hole exists in everyone before birth, but most often closes shortly after a baby is born.  
Explain why the hole in the septum separating the atria does not cause problems in a baby before it is born.



1

Q.116 Shown below are the diagrammatic representations of the circulatory systems of three organisms X, Y and Z.

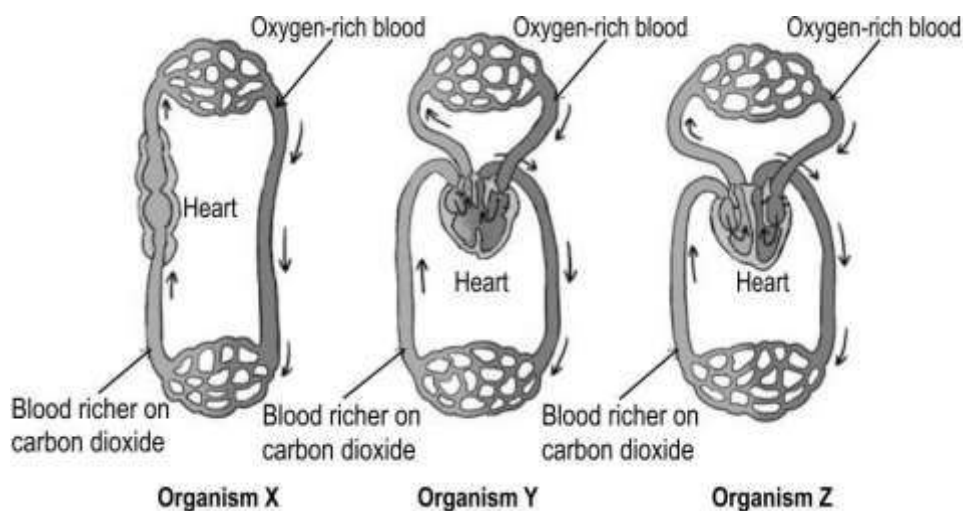
3



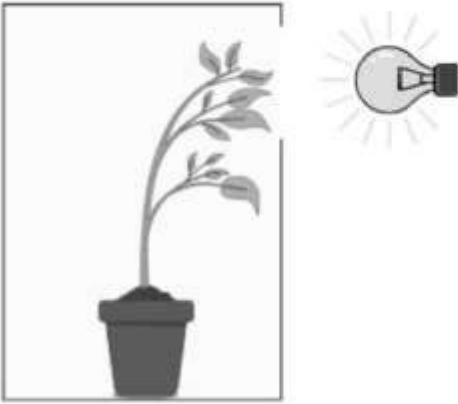

(a) Identify which organism is a fish. Give a reason for your answer.  
(b) Identify the organism(s) that does/do NOT require energy to maintain their body temperature.

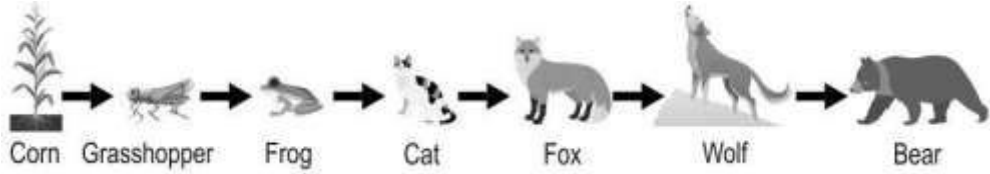
<p>Q.117</p>	<p>The two pictures below illustrate tropism in plants. P shows a plant bending towards light. Q shows a plant twining around a pole.</p> <div style="display: flex; justify-content: space-around; align-items: center;"> <div style="text-align: center;">  <p>P. Plant bending towards light</p> </div> <div style="text-align: center;">  <p>Q. Plant twining around a pole</p> </div> </div> <p>Based on the pictures, what is true about the growth rate of the plant cells on the side away from the stimulus as compared to the growth rate of the plant cells on the side towards the stimulus?</p>	<p>1</p>
<p>Q.118</p>	<p>The picture below shows a cow looking for food in the garbage.</p> <div style="text-align: center;">  </div> <p>Very often, while eating some food the animal also swallows plastic. The plastic that the animal swallows remains undigested and accumulates in the stomach. This eventually leads to starvation as there is less and less space for real food.</p> <p>Give one reason for plastic remaining undigested in an cow's stomach.</p>	<p>1</p>
<p>Q.119</p>	<p>In the food chain given below, which position would a vulture occupy? Justify your answer.</p> <p>Plants -----&gt; Rabbit -----&gt; wild cat -----&gt; lion</p>	<p>2</p>
<p>Q.120</p>	<p>Observe the food chain shown below.</p>	<p>2</p>

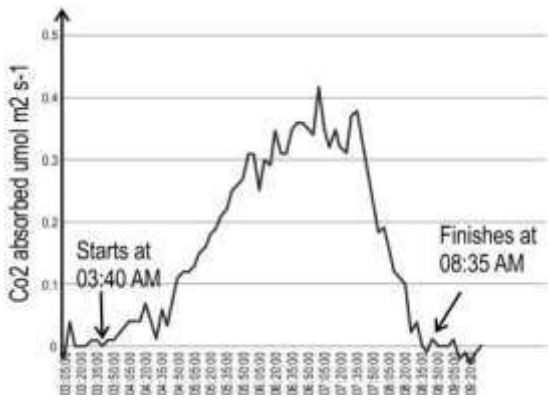
	 <p>Is such a food chain likely to exist in nature? Justify your answer.</p>	
Q.121	<p>'Plants and animals give out carbon dioxide all the time.'</p> <p>Is this statement true or false? Justify your answer.</p>	2
Q.122	<p>State what is required for two or more food chains to form a food web.</p>	1
Q.123	<p>Raman's mother moved her leg immediately as she saw that she was about to step on Raman's toy.</p> <p>Netra says this action is a reflex action as it was a quick action whereas Kabir says it was a reflex action because it was an involuntary response.</p> <p>Is either of them CORRECT? Justify your answer.</p>	2
Q.124	<p>A scientist wanted to determine whether a tall pea plant X was TT or Tt.</p> <p>To do this he crossed two X plants:</p> <p>(i) one with a pea plant known to carry the TT traits</p> <p>(ii) one with a pea plant known to carry the tt traits</p> <p>(a) Considering that X could be TT or Tt, what ratios would he obtain in both crosses - (i) and (ii)? Show the crosses.</p> <p>(b) Based on the ratios obtained in (a), a cross with which parent - (i) or (ii) - would help in identifying whether X was TT or Tt? Justify.</p>	5
Q.125	<p>Genetic drift can greatly increase variation in a population.</p> <p>Is this statement TRUE? Justify.</p>	2
Q.126	<p>Give ONE reason why genetic drift is not the same as natural selection.</p>	1
Q.127	<p>Before Darwin's theory of evolution, another theory existed that postulated that any physical changes that occurred in an organism through its lifetime could be transmitted to its offspring.</p> <p>Using one example, explain why this theory cannot be true.</p>	2
Q.128	<p>One parent suffered from a disease which was then seen only in the male children of subsequent generations and not seen in the female children.</p> <p>Is this disorder likely to be linked to the sex chromosome of the individuals or not? Justify your answer.</p>	1
Q.129	<p>Justify the following statements:</p> <p>(a) Organisms that originate from a common ancestor may look very different from each other.</p>	2

	(b) Organisms that have similar-looking structures may not necessarily come from a common ancestor.	
Q.130	<p>(a) Ketaki thinks that the fresh dialysing fluid that enters the dialysis machine is rich in urea.</p> <p>Is she correct? Why or why not?</p> <p>(b) Urination is a _____ (voluntary/involuntary/both voluntary and involuntary) process.</p>	2
Q.131	<p>In diabetic patients, with high blood glucose levels, the urine sample also consists of high levels of glucose. This is mainly because, in the nephron, glucose is not reabsorbed back into the blood.</p> <p>Explain why does reabsorption not take place in two points.</p>	2
Q.132	<p>In respiration, glucose is broken down into a 3-C molecule called pyruvate, in the cytoplasm of the cell.</p> <p>Is this particular process aerobic or anaerobic in nature? Justify your answer.</p>	1
Q.133	<p>The graph below shows the hours of the day during which a plant absorbs CO<sub>2</sub>.</p>  <p>(a) In what kind of weather conditions is this plant likely to be growing? Give a reason to support your answer.</p> <p>(b) When is photosynthesis likely to happen in such plants?</p>	2
Q.134	<p>Walnut plants belong to a category of plants where the male and female flowers grow separately on the same plant. A scientist took three plants - P, Q and R. He removed the male flowers from plant P and the female flowers from plant Q. Plant R, he left as it is - with both flowers on the same plant. He kept all three plants in an open space.</p> <p>Will any of these plant/s bear fruits? Justify your answer.</p>	2
Q.135	<p>Consider a woman suffering from a disease that is not linked to the sex chromosome. A geneticist wanted to know the likelihood of this disease passing on to future generations. To identify this, it was important to identify if the disease is caused by a dominant allele or a recessive one. The geneticist made a chart of the appearance of this disease in the family members related to the woman.</p>	2

	State TWO observations in the family history that will help the geneticist identify that the disease is caused by a dominant trait.	
Q.136	<p>A terrarium contains soil and a variety of plants inside a glass container. It is watered and sealed. The soil gives the required nutrients, and plants use the carbon dioxide present in the air inside the container to prepare food using sunlight.</p>  <p>(a) Can this terrarium be called an ecosystem? Give a reason.  (b) List the biotic and abiotic components of this ecosystem.</p>	3
Q.137	<p>Neuronal coordination of the body is generally much faster than chemical coordination of the body.</p> <p>Mark the above statement as true or false and justify your answer.</p>	2
Q.138	<p>Here is a picture of a germinating seed.</p>  <p>(a) What is the environmental stimulus required for the seed to develop roots downwards and shoots upwards? Name the respective phenomenon.  (b) What environmental factor in the experimental setup shown below can be altered in Figure X to observe the direction of root growth as observed in Figure Y?</p>	3



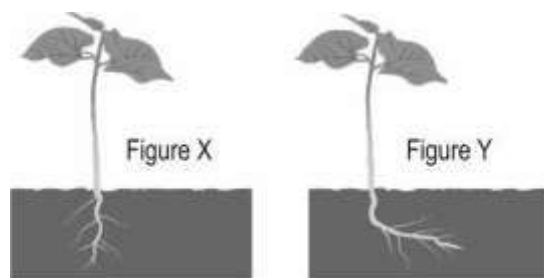

(c) Name the tropic movement that occurs when pollen tubes grow towards ovules.

Q.139

(a) What is the role of auxin in a plant?  
 (b) What should be the direction of light for the shoot tip to bend toward a side as given in the image below?

3

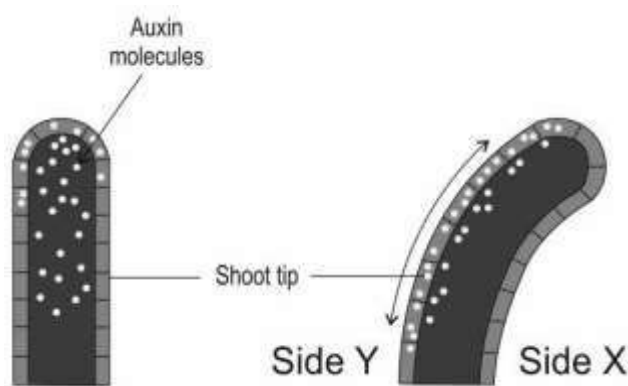

(c) Describe the mechanism involved in the bending of a shoot tip due to stimulation by light.

Q.140

The thyroid hormone controls the body's metabolism. The two main hormones thyroid releases are thyroxine (T4) and triiodothyronine (T3), which collectively comprise the thyroid hormone. The thyroid-stimulating hormone (TSH) in the pituitary gland stimulates the thyroid to release the hormones.

3

Ram lives in a remote part of a Himalayan village. He visited the doctor with symptoms of tightness in the throat and a hoarse voice. The doctor asked for a thyroid profile and blood sugar test.

Given below are the test results:

Test	Normal/Reference range	Amount in sample
TSH	0.4-5 mIU/L	6 mIU/L
T3	4.6-12 µg/dL	1.76 µg/dL
T4	80-180 ng/dL	21 ng/dL
Blood sugar (post-meal)	170-200 mg/dL	180 mg/dL

	<p>(a) What could be the deficiency disease Ram maybe suffering from? Justify.</p> <p>(b) State TWO reasons why the doctor prescribed a thyroid test.</p>	
Q.141	<p>Raghav was watching Nia and made the following observation:</p> <p>Nia was practicing boxing. As her opponent swung an arm, Nia blinked her eyes and ducked down. Nia retaliated with a punch.</p> <p>(a) Raghav said that the blinking of eyes and ducking down are both reflex actions. Is he correct? Justify.</p> <p>(b) Explain the nervous process involved in Nia's retaliation with a punch in TWO points.</p>	4
Q.142	<p>Raj is blindfolded. He is made to taste the food without seeing it. He concludes that the food is burnt.</p> <p>(a) What specific component of the tongue helped him conclude the taste of the food?</p> <p>(b) If the food was crunchy, which part of the brain would help him recognise this texture of the food?</p>	2

## Answer Key and Marking Scheme

Q. No	Answers	Marks
Q.73	A. Only P	1
Q.74	A. They are analogous organs with same functions.	1
Q.75	A. Both A and R are true and R is the correct explanation of A.	1
Q.76	B. Only rock and sunlight	1
Q.77	D. Only primary, secondary and tertiary consumers	1
Q.78	C. E/1000	1
Q.79	C. (A) is false, but (R) is true	1
Q.80	B. Only P and R	1
Q.81	D. A is false, but R is true.	1
Q.82	C. 50%	1
Q.83	A. 0%	1
Q.84	C. 50%	1
Q.85	C. Object is moved closer to the eye	1
Q.86	B. Only Y	1
Q.87	A. Myopia	1
Q.88	D. Ant	1
Q.89	D. A is false, but R is true.	1
Q.90	C. Relaxation of the ciliary muscles	1
Q.91	D. Fertilisation	1
Q.92	B. Only Q	1
Q.93	D. when the tendril is in contact with a surface	1
Q.94	A. Only P	1
Q.95	B. Germination of pollen grains on the stigma	1

Q.96	B. Walking in a straight line	1
Q.97	C. Abscisic acid is released in response to the scarcity of water.	1
Q.98	(a) protein (b) emulsification (c) Digestive enzymes in the stomach need an acidic medium while those in the small intestine need an alkaline medium.	3
Q.99	1 mark for each:  - Red-colored ladybugs have an evolutionary advantage.  - This is because they are present in the largest numbers throughout the country.	2
Q.100	1 mark for each reason:  - She does not remove any part from the flowers to be pollinated because the female pumpkin flowers don't have any male parts.  - She still ties the pollinated flowers because the pollen from other male flowers can still reach the stigma.  (Award marks for any other correct justification)	2
Q.101	Yes, it does. [0.5 marks]  The effect of adrenaline is to prepare the muscles of the body for a fight or escape response. [0.5 marks]	1
Q.102	(a) 0.5 marks for each correct name:  (i) circulatory and respiratory systems  (ii) nervous system  (b) increased carbon dioxide quantity in blood	2
Q.103	(a) 1 mark for each of the following:  Part Q - Fallopian tube  Function - Acts as the fertilization place for egg & sperm.  (b) 0.5 mark for each of the following:  - No, she is not correct	3

	<p>- Eggs are produced in the ovaries which are intact.</p> <p>OR The uterus does not play a role in producing eggs.</p> <p>[Accept any other valid reason.]</p>	
Q.104	<p>- New sugarcane plants are produced by vegetative propagation which is an asexual method of reproduction. Only one parent is involved and there is no mixing of gametes. [1 mark]</p> <p>- Humans reproduce through sexual reproduction involving two parents and the mixing of male and female gametes, which results in the offspring having the genes of both parents. [1 mark]</p>	2
Q.105	<p>(a) 1 mark for each of the following:</p> <p>- Cyanobacteria in box X are likely to have better growth.</p> <p>- Cyanobacteria are photosynthetic bacteria that need sunlight which can enter only in box X as it has an opening.</p> <p>(b) The containers should be kept in the open, where there is maximum exposure to sunlight.</p>	3
Q.106	<p>(a) Insulin would be released in response to the high glucose level.</p> <p>(b) 1 mark for each of the following points:</p> <p>- When the level of glucose increases, the cells of the pancreas release insulin.</p> <p>- When the level of glucose is stabilized, the cells of the pancreas regulate the production of insulin and reduce insulin production through a feedback mechanism.</p>	3
Q.107	<p>(a) Growth needs to be observed in each of the following plants:</p> <p>- Keep a blue pea plant with a stick in the dark and another one with a stick in the sunlight [1 mark]</p> <p>- Keep another blue pea plant without a stick in the dark and another one without a stick in the sunlight [1 mark]</p> <p>(b) 1 mark for each point:</p> <p>- The venus fly trap plant's leaves have hairs sensitive to touch.</p> <p>- When a fly sits on the leaf, it triggers/stimulates the hairs and in response to this the leaf traps shut.</p>	4

Q.108	<p>(a) Ria's lack of reaction in response to the tapping of the patellar tendon indicates possible damage to the central nervous system or a neurological problem.</p> <p>(b) 1 mark for each of the following:</p> <ul style="list-style-type: none"> <li>- If Ria sees a sharp object and does not step on it, it is a voluntary action.</li> <li>- The neural path followed is - signal from the eyes is passed to the brain, and from the brain, the message is passed to move away by the motor nerve to the legs/effector organ.</li> </ul> <p>(c) 1 mark for each of the following:</p> <ul style="list-style-type: none"> <li>- Tapping of the patellar tendon initiates the neural signal, which is transmitted through the sensory neuron to the spinal cord.</li> <li>- From the spinal cord, the signal to stretch the leg is passed through the motor neuron to the leg muscle.</li> </ul>	4
Q.109	<p>Ria is correct. (1 Mark)</p> <ul style="list-style-type: none"> <li>-The sky appears blue as blue light has a shorter wavelength than red light.</li> <li>-Scattering is inversely proportional to the wavelength of light.</li> </ul> <p><i>(Give 1 mark if both points are mentioned)</i></p>	2
Q.110	<p>(a) Roopa could have used any transparent object which could be made of glass or plastic.</p> <p>(b) 1 mark for each of the following:</p> <ul style="list-style-type: none"> <li>- Light goes through two refractions in the object. The first one is the air-glass interface when light is incident on the object.</li> <li>- The second one is the glass-air interface when the ray of light emerges out of the object. This happens because light has travelled from an optically denser medium to an optically rarer medium.</li> </ul>	3
Q.111	<p>(a) One of the celestial objects was twinkling, while the other was not. (1 mark)</p> <p>(b)</p> <ul style="list-style-type: none"> <li>- If the celestial objects were to be observed from the moon, Tina would not be able to distinguish them as a star or a planet.</li> <li>- Since there is no atmosphere on the moon, stars would not appear to twinkle.</li> </ul> <p>(1 mark for each point.)</p>	3

Q.112	<p>(a) The lens of the eye, because it has the ability to adjust its focal length.</p> <p>(b) When we are looking at nearby objects closer, the ciliary muscles contract. This increases the curvature of the eye lens. The eye lens then becomes thicker. The focal length of the eye lens decreases. This enables us to see nearby objects clearly.</p> <p>(c) The curvature of the eye lens can be modified to some extent by the ciliary muscles. The change in the curvature of the eye lens changes its focal length. When the muscles are relaxed, the lens becomes thin, and its focal length increases. This enables us to see distant objects clearly.</p>	3
Q.113	<p>1 mark each for the following:</p> <ul style="list-style-type: none"> <li>- Figure P: 120</li> <li>- Figure Q: 80</li> </ul>	2
Q.114	<p>0.5 marks for each of the following:</p> <ul style="list-style-type: none"> <li>- pharynx</li> <li>- oesophagus</li> <li>- stomach</li> <li>- small intestine</li> <li>- large intestine</li> <li>- anus</li> </ul>	3
Q.115	<p>A baby does not use its lungs when it is growing in the womb. [1 mark]</p> <p>OR</p> <p>The hole in the septum does not cause problems in an unborn infant as the developing embryo gets nutrition and oxygen from the mother's blood through the placenta and umbilical cord. [1 mark]</p>	1
Q.116	<p>(a) organism X [1 mark]</p> <p>1 mark for any one of the following:</p> <ul style="list-style-type: none"> <li>- fishes have a two-chambered heart.</li> <li>- In fishes, the blood passes through the heart only once during one cycle</li> </ul> <p>(b) 0.5 marks each for the following:</p>	3

	<ul style="list-style-type: none"> <li>- organisms X</li> <li>- organism Y</li> </ul>										
Q.117	The cells on the side away from the stimulus grow faster than the cells on the side of the stimulus.	1									
Q.118	Cows do not produce the enzyme required to break down and digest plastic material.	1									
Q.119	<p>A vulture would occupy a position after the lion.</p> <p>Vultures are scavengers that feed on the remains of dead organisms.</p>	2									
Q.120	<p>Such a food chain is not likely to exist in nature.</p> <p>The food chain shown has too many trophic levels. Due to the loss of energy at each level, there will not be enough energy available at the higher trophic levels.</p>	2									
Q.121	<ul style="list-style-type: none"> <li>- True. [1 mark]</li> <li>- Plants and animals respire continuously and hence give out the product of respiration, carbon dioxide, all the time. [1 mark]</li> </ul> <p>(No marks to be awarded without justification.)</p>	2									
Q.122	<p>They must have an organism that is eaten by two or more other kinds of organisms.</p> <p><i>[Accept any other valid answer.]</i></p>	1									
Q.123	<p>0.5 marks for each of the following:</p> <ul style="list-style-type: none"> <li>- Neither of them is correct.</li> <li>- The action was a voluntary action in response to seeing the toy.</li> </ul> <p><i>[Accept any other valid justification.]</i></p>	2									
Q.124	<p>(a) 0.5 marks each for the correct crosses and the correct ratios:</p> <p>(i) <b>If X was TT</b></p> <table border="1" style="margin-left: auto; margin-right: auto;"> <tr> <td></td> <td>T</td> <td>T</td> </tr> <tr> <td>T</td> <td>TT</td> <td>TT</td> </tr> <tr> <td>T</td> <td>TT</td> <td>TT</td> </tr> </table>		T	T	T	TT	TT	T	TT	TT	5
	T	T									
T	TT	TT									
T	TT	TT									



All tall plants would be obtained.

If X was Tt

	T	t
T	TT	Tt
T	TT	Tt

All tall plants would be obtained.

(ii) If X was TT

	T	T
t	Tt	Tt
t	Tt	Tt

All tall plants would be obtained.

If X was Tt

	T	t
t	Tt	tt
t	Tt	tt

1:1 ratio of tall:short plants.

*[Award marks if the cross is shown in any other correct manner.]*

(b) 0.5 marks for each of the following:

- (ii) would be helpful

- In (ii), the ratios of offspring obtained were different for TT and Tt whereas in (i) the ratios were the same for TT and Tt so it would not be possible to determine whether X is TT or Tt based on (i).

Q.125 1 mark for each of the following:

2

	<p>- False.</p> <p>- Genetic drift causes a change in the population of species which can result in the wiping out of some variants completely which results in decreased variation in a population.</p> <p><i>[Accept any other valid justification. No marks to be awarded if the correct justification is not written.]</i></p>	
Q.126	Genetic drift is a chance event that does not depend on a trait's suitability to the environment which drives natural selection.	1
Q.127	<p>1 mark for each of the following:</p> <p>- Humans with amputated legs give birth to children with properly formed limbs.</p> <p>- This theory talks about the inheritance of non-genetic characteristics which do not affect the genetic makeup of an organism.</p> <p><i>[Accept any other valid answer.]</i></p>	2
Q.128	<p>0.5 marks for each of the following:</p> <p>- Yes it is linked to the sex chromosome/Y chromosome.</p> <p>- If it was not linked to the Y chromosome it would be seen in the daughters as well.</p>	1
Q.129	<p>1 mark for each of the following:</p> <p>(a) Over time, mutations and variations cause organisms coming from the same ancestor to accumulate a lot of differences causing them to look very different from each other.</p> <p>(b) It is possible for unrelated organisms to have similar-looking organs especially when they live in similar environments/undergo the same selective pressure.</p> <p><i>[Accept any other valid answer.]</i></p>	2
Q.130	<p>(a)</p> <p>- No she is not correct. <i>[0.5 marks]</i></p> <p>- During dialysis, nitrogenous wastes such as urea leave the blood and enter the dialysing fluid by diffusion due to a concentration difference and so urea cannot be present in the fluid otherwise urea from the blood will not get excreted into the dialysing fluid. <i>[1 mark]</i></p>	2

	(b) both voluntary and involuntary	
Q.131	<p>1 mark for each of the following:</p> <ul style="list-style-type: none"> <li>- Reabsorption of nutrients in the nephron is a process mainly driven by osmosis.</li> <li>- When some of the glucose from the blood is filtered in the urine, it does not get reabsorbed as the concentration of glucose is already high in the blood and so there is little/no concentration gradient causing glucose to be retained in the urine.</li> </ul>	2
Q.132	<p>0.5 marks for each of the following:</p> <ul style="list-style-type: none"> <li>- anaerobic</li> <li>- This step occurs in all organisms, even those that respire anaerobically and so this process is likely to be anaerobic.</li> </ul> <p><i>[Accept any other valid answer.]</i></p>	1
Q.133	<p>(a) 0.5 marks each for the following:</p> <ul style="list-style-type: none"> <li>- in dry and arid conditions/deserts</li> <li>- Since gas exchange is not happening in the day, it indicates that stomata is likely to be closed, which is common in dry conditions.</li> </ul> <p>(b) in the day</p>	2
Q.134	<ul style="list-style-type: none"> <li>- Plants P and R will bear fruits [0.5 marks for naming each plant]</li> <li>- Plant P has the female reproductive organs which can receive pollen and fertilisation can take place. [0.5 marks]</li> <li>- Plant R has both sexes on the same plant facilitating pollination and fertilisation. [0.5 marks]</li> </ul>	2
Q.135	<p>1 mark each for any TWO of the following:</p> <ul style="list-style-type: none"> <li>- At least one parent of the woman will also have the disease.</li> <li>- Other than her, some of her siblings would also have the disease.</li> <li>- In each generation, one or more individuals will have the disease.</li> </ul> <p><i>[Accept any other valid answers.]</i></p>	2
Q.136	<p>(a) The terrarium can be called an ecosystem because all the components of the terrarium are interacting with each other.</p>	3

	<p>(b)</p> <ul style="list-style-type: none"> <li>- The biotic components are the variety of plants and other organisms present in the soil. [1 mark]</li> <li>- The abiotic components are soil, sunlight, air and water. [give 1 mark if all the components are written]</li> </ul>	
Q.137	<p>True</p> <p>Neuronal coordination is faster due to rapid electrical signalling, direct point-to-point communication, and immediate responses, whereas chemical coordination relies on slower hormone diffusion through the bloodstream.</p>	2
Q.138	<p>(a) 0.5 marks for identifying the stimulus and 0.5 marks for naming the phenomenon.</p> <ul style="list-style-type: none"> <li>-roots growing downwards- stimulus: gravity, phenomenon: positive geotropism</li> <li>-shoot growing upwards-stimulus: sunlight, phenomenon: positive phototropism</li> </ul> <p>(b) The environmental factor that can be altered is adding a source of water/nutrients towards one side of the root.</p> <p>(c) The tropic movement that occurs when pollen tubes grow towards ovules is called chemotropism.</p>	3
Q.139	<p>(a) 0.5 marks for each keyword.</p> <p>Auxin in the plant promotes:</p> <ul style="list-style-type: none"> <li>-cell growth</li> <li>-cell elongation.</li> </ul> <p>(b) The light source should be at Side X for the shoot tip to bend</p> <p>(c) 0.5 marks for each point</p> <ul style="list-style-type: none"> <li>- When the light comes from one side of the plant, then the plant hormone auxin gets diffused towards the side of the shoot that is away from sunlight.</li> <li>- This concentration of auxin stimulates cell growth and elongation on the side of the shoot away from light.</li> </ul>	3
Q.140	<p>(a) 0.5 marks each for the following:</p> <ul style="list-style-type: none"> <li>- The deficiency disease is goitre.</li> </ul>	3

	<p>- T3 and T4 level for Ram is less than the given normal range while TSH is high.</p> <p>(b) 1 mark each for the following:</p> <p>- The geographical location of Ram indicated the possibility of low levels of iodine availability in food.</p> <p>-The symptoms described indicated iodine deficiency.</p>	
Q.141	<p>(a)1 mark for each point</p> <p>- Blinking of eyes is not a reflex action. It is an involuntary action that happens with or without a stimulus.</p> <p>- Nia ducked down because of reflex action.</p> <p>(b)1 mark for each point</p> <p>-Nia's brain received the signal from the eyes through sensory nerves, and the brain processed this signal.</p> <p>- The brain sent the signal to the hand, through motor nerves to punch back</p>	4
Q.142	<p>(a) The gustatory receptors on the tongue help us to identify the taste of the food.</p> <p>(b) Fore brain has a specialized function of hearing. Crunch in the food can be heard, and this is processed by the forebrain</p>	2

## 17. NATURAL PHENOMENA

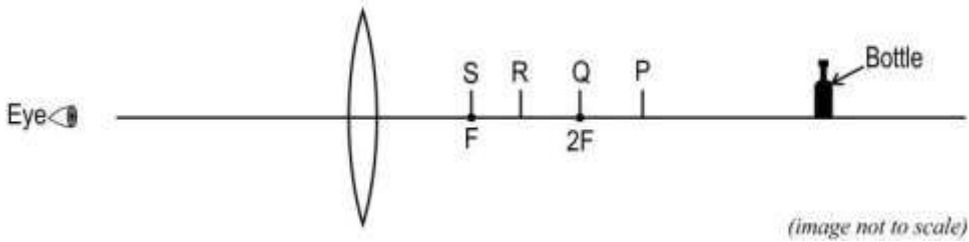
Q.No	Question	Marks
<b>Multiple Choice Question</b>		
Q.143	<p>Diabetic retinopathy causes damage to blood vessels in the retina.</p> <p>Which of the following would NOT happen in a person having diabetic retinopathy?</p> <p>A. Focussing on objects at different distances            B. Formation of a clear image of the object            C. Change in the size of the pupil            D. Entry of light into the eye</p>	1
Q.144	<p>A bottle is viewed through a convex lens as shown below. The bottle appears inverted at first. The bottle is now moved slowly towards the lens.</p>  <p>At which of the marked points will the image appear upright?</p> <p>A. P            B. Q            C. R            D. S</p>	1
Q.145	<p>Two statements are given below - one labelled Assertion (A) and the other labelled Reason (R).</p> <p>Assertion (A): For making danger signals and signs that are at a distance, a colour with a longer wavelength is used.</p> <p>Reason (R): Colours with longer wavelengths travel faster than the other colours.</p> <p>Which of the following is correct?</p> <p>A. Both A and R are true, and R is the correct explanation for A.            B. Both A and R are true, but R is not the correct explanation for A.            C. A is true, but R is false.</p>	1

D. A is false, but R is true.

**Free response question/Subjective Question**

Q.146 The image given below indicates defective vision in Ram.

5

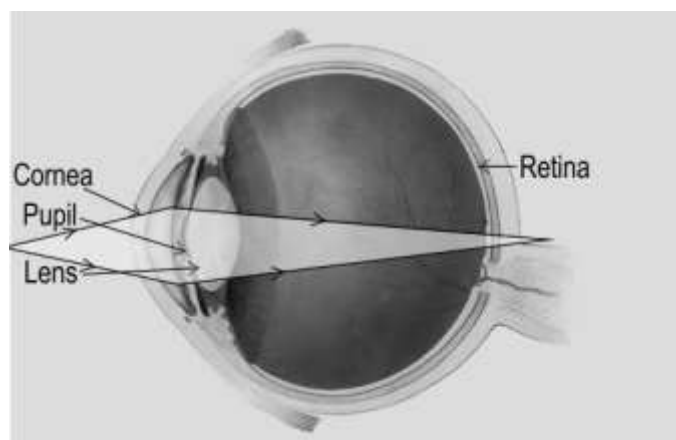

- (a) Based on the given information, what could be the nature of the eye defect?  
(b) State the type of lens to be used to correct his vision. Justify your choice.  
(c) The near point of Ram's eye is 75 cm. Calculate the focal length and power of the lens he should use while reading a book kept at a distance of 25 cm from the eye.

Q.147 Neeti took some clear gel beads and soaked them in water for a few hours. The gel beads absorbed water and increased in size. She then placed these beads in a glass container. The beads were clearly visible in the container as shown below.

2

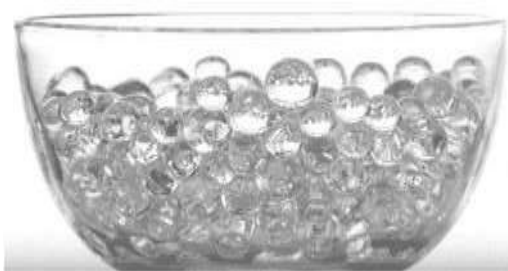

Neeti then added water to the container and it appeared as shown below.

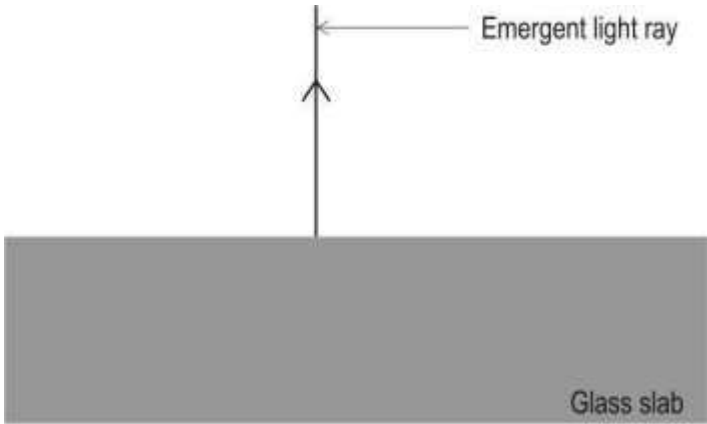
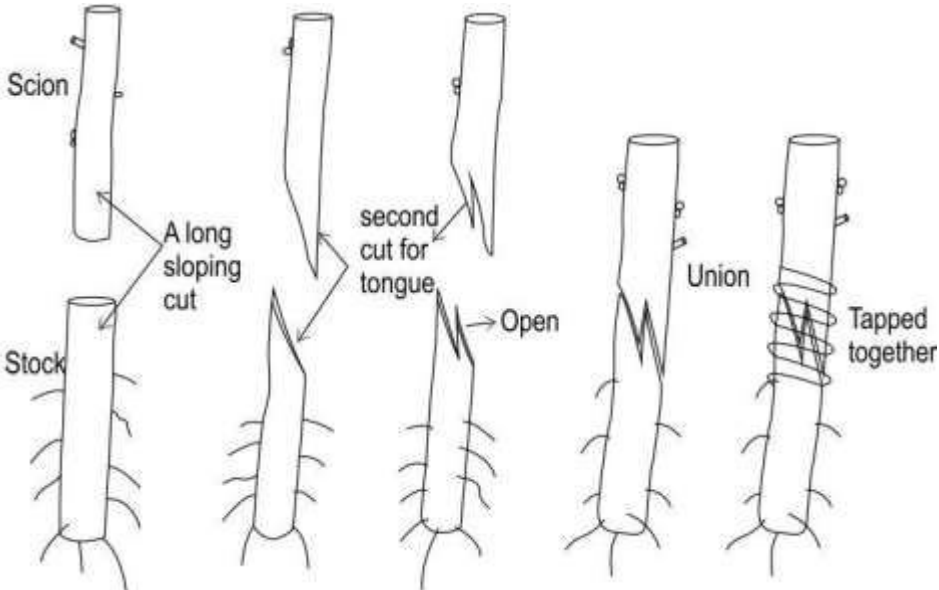

(a) Why are the gel beads not visible on adding water?

	(b) Would the gel beads shown in the first image be visible if placed in oil instead of water? Give a reason for your answer.	
Q.148	<p>The ray of light emerging from a rectangular glass slab into air is shown in the diagram below.</p>  <p>Copy the diagram and draw the path of the same light ray as it enters from air and passes through the glass slab.</p>	2
Q.149	<p>The ozone layer absorbs harmful ultraviolet rays. Chlorine released by certain substances such as chlorofluorocarbons (CFCs) and hydrochlorofluorocarbons (HCFCs) contributes to ozone depletion.</p> <p>Large volcanic eruptions produce large amounts of tiny particles called aerosols, which increase chlorine's effectiveness in destroying ozone.</p> <p>State one possible reason why erupting volcanoes, though increasing chlorine's effectiveness at destroying ozone, do not pose a serious threat to the ozone layer.</p>	1
Q.150	<p>Ajay took a stem cutting (scion) from a red rose plant and a stem (stock) from a white rose plant. After cutting both the stems, he arranged and tied them as shown below.</p> 	2

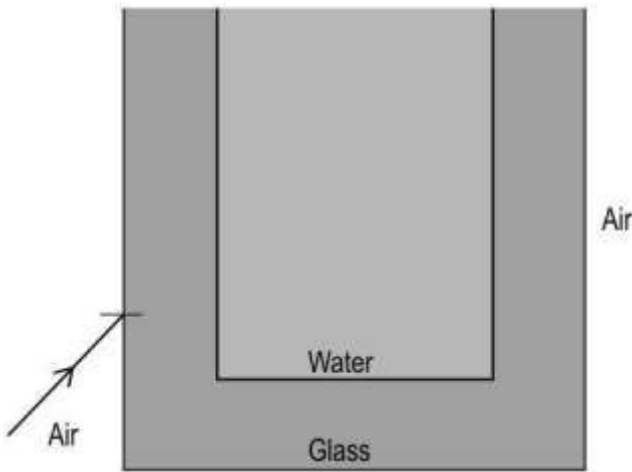

	(a) Name the type of asexual reproduction seen here. (b) What will be the colour of the roses that will be produced in the new plant?	
Q.151	State TWO points of similarities between the processes of reproduction in hydra and bryophyllum.	2
Q.152	A concave lens has a power of $-2.0D$ . It forms an image of an object at a distance of 10 cm from the lens. (a) Find the distance of the object from the lens. (b) Find the magnification produced.	4
Q.153	A light ray is incident on the wall of a glass tank as shown below.  Draw a rough diagram of the path of the light ray as it passes through the glass tank and the water and emerges again into air. Draw the normal at each interface.	3
Q.154	While walking along the riverbank, Trupti found a smooth, milky white stone. When a ray of sunlight fell upon it, she observed that the stone appeared bluish in colour and the light that passed through it appeared orange in colour. (a) Identify the phenomenon that Trupti observed as sunlight fell upon the stone. (b) How would the size of the stone particles compare to the wavelength of visible light?	2

## Answer Key and Marking Scheme

Q. No	Answers	Marks
Q.143	B. Formation of a clear image of the object	1
Q.144	D. S	1
Q.145	B. Both A and R are true, but R is not the correct explanation for A.	1
Q.146	<p>(a) The nature of the eye defect is hypermetropia.</p> <p>( 1 mark for correct answer)</p> <p>(b) 1 mark for each point</p> <p>-The type of lens to be used to correct his vision is a convex lens.</p> <p>- The image of a nearby object is being formed behind the retina and by using a convex lens the light rays can be converged further causing the image to be focused correctly on the retina.</p> <p>(c)0.5 mark for the formula, 0.5 mark for the final answer</p> $\frac{1}{f} = \frac{1}{v} - \frac{1}{u}$ $\frac{1}{f} = \frac{1}{-75} - \frac{1}{-25}$ $\frac{1}{f} = -\frac{1}{75} + \frac{1}{25}$ $f = 20cm$ <p>For distant vision,</p> <p>The focal length is <math>p = 1/f</math></p> $p = 100/20$ $p = 5 D$	5
Q.147	<p>(a) The water-filled gel beads have nearly the same refractive index as water and hence light does not bend as it moves from water to the beads.</p> <p>(b) The gel beads would be visible when placed in oil, as the refractive index of water is different from that of the oil.</p>	2
Q.148	1 mark for drawing the incident ray entering the glass slab and 1 mark for drawing the refracted ray as it passes through the glass slab:	2

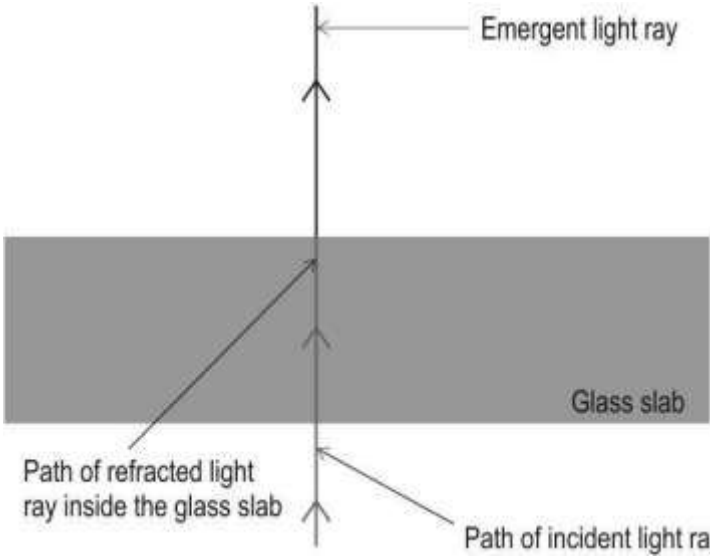
		
Q.149	Volcanic eruptions do not occur frequently.	1
Q.150	<p>(a) It is also called vegetative propagation/grafting.</p> <p>(b) The new plant would produce red flowers.</p>	2
Q.151	<p>(1 mark for each point )</p> <ul style="list-style-type: none"> <li>- The offspring that are produced are genetically identical to the parent.</li> <li>- Single parent is involved in the process of reproduction.</li> </ul> <p>(Accept any other valid points)</p>	2
Q.152	<p>(a)</p> <p>Power of lens <math>D = -2.0 = 1/f</math></p> <p><math>f = -1/2 = -50 \text{ cm}</math> [1 mark]</p> <p>lens formula <math>1/v - 1/u = 1/f</math> [1 mark]</p> <p><math>1/u = 1/v - 1/f = 1/-10 - (1/-50)</math></p> <p><math>= -5 - (-1) / 50</math></p> <p><math>= -4/50</math></p> <p><math>u = 50/-4 = -12.5 \text{ cm}</math> [1 mark]</p> <p>(b) magnification <math>= v/u</math></p> <p><math>= -10/-12.5 = 0.8</math></p>	4

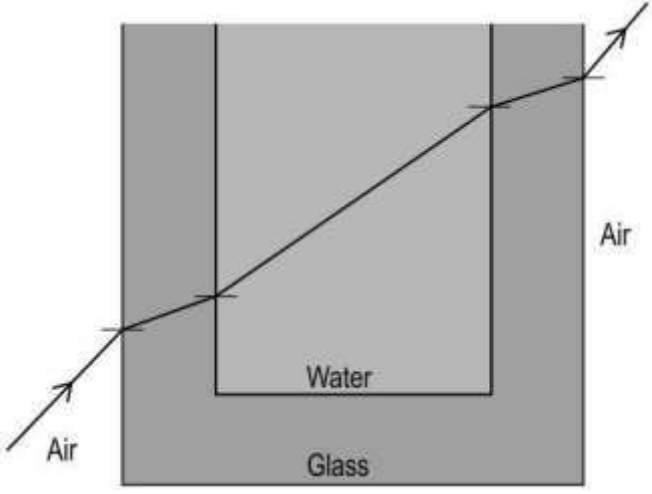
<p>Q.153</p>	 <p>(0.5 marks each for drawing the rays correctly at each interface. 1 Mark for drawing the normal at each interface.)</p>	<p>3</p>
<p>Q.154</p>	<p>(a) scattering of light</p> <p>(b) The stone particles would be smaller than the wavelength of visible light.</p>	<p>2</p>

## 18. EFFECTS OF CURRENT

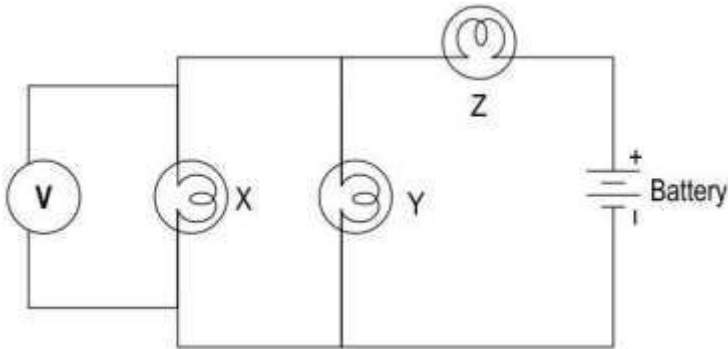
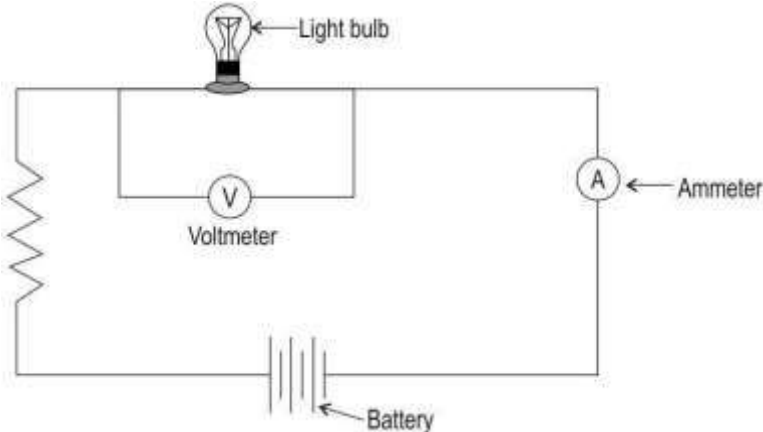
Q.No	Question	Marks
<b>Multiple Choice Question</b>		
Q.155	<p>The electric circuit below consists of a voltmeter, a battery and three bulbs X, Y and Z.</p>  <p>The reading on the voltmeter represents the potential difference across which bulb(s)?</p> <p>A. Only X            B. Both X and Y            C. Both X and Z            D. All X, Y and Z</p>	1
<b>Free response question/Subjective Question</b>		
Q.156	<p>Of all the components in the circuit shown below, the current flowing through the voltmeter is the least.</p> <p>Explain why.</p> 	1

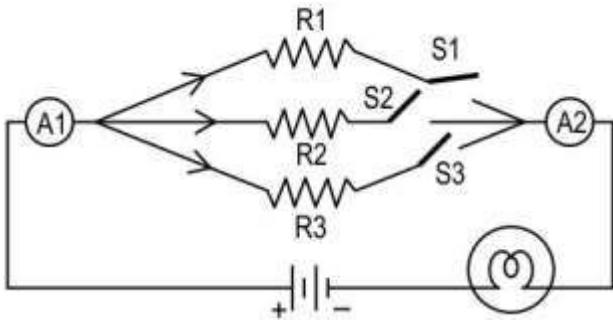
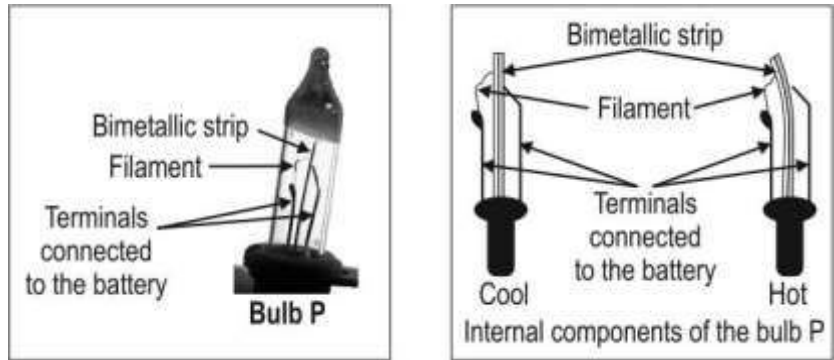
<p>Q.157</p>	<p>The circuit shown below has a bulb, three resistors R1, R2 and R3, and three switches S1, S2 and S3. There are also two ammeter A1 and A2 in the circuit.</p>  <p>How will the reading on ammeter A2 compare with the reading on ammeter A1 when</p> <p>(i) All the three switches are closed?</p> <p>(ii) One switch is closed?</p>	<p>1</p>
<p>Q.158</p>	<p>Before cleaning the light bulb in his room, Gautam turned off the light by turning the switch off. Yet, he received an electric shock while cleaning the bulb.</p> <p>Explain why the bulb connection was live though the switch was off.</p>	<p>1</p>
<p>Q.159</p>	<p>The picture shown below is of a special bulb P which is used in some circuits of series lights. Its filament is joined to the two terminals through a bimetallic strip, as shown. When the filament gets heated and glows, it also heats up the bimetallic strip which bends when heated.</p>  <p>Besides its function as a light bulb, which other component of a normal electric circuit is this bulb likely to function as? Justify your answer.</p>	<p>3</p>
<p>Q.160</p>	<p>The picture below shows two diagrams of the wiring of an electric clothes iron. The thermostat is a device that can be set at a particular temperature, and controls the heating temperature of the iron by automatically shutting off and on. The indicator light is connected differently in the two diagrams.</p>	<p>4</p>

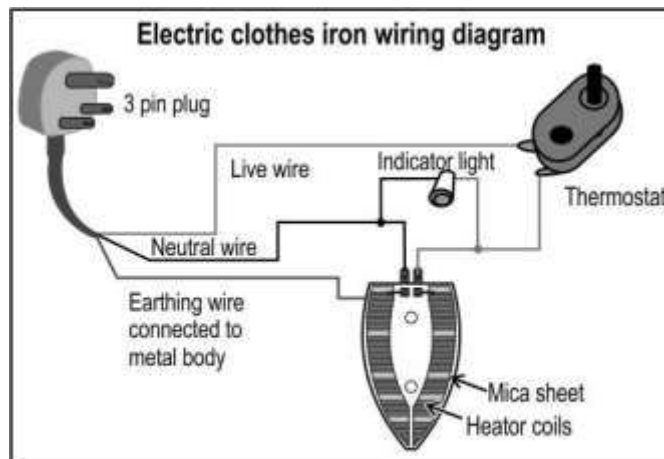

Figure 1

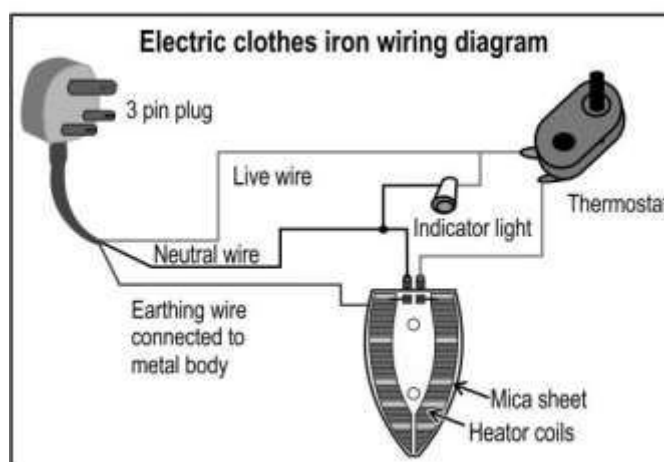

Figure 2

- Explain how the difference in the connections affects the functioning of the indicator light.
- Does this difference change the heating of the iron? Justify your answer.
- State the function of the earthing wire.

## Answer Key and Marking Scheme

Q.No	Answers	Marks
Q.155	B. Both X and Y	1
Q.156	Of all the components, the voltmeter has the highest resistance.	1
Q.157	The reading on ammeter A2 will be the same as the reading on ammeter A1. The reading on ammeter A2 will be equal to the reading on ammeter A1. 0.5 mark for each correct answer.	1
Q.158	The switch was connected in the neutral wire instead of the live wire.	1
Q.159	The bulb acts as a switch, shutting the lights off and on. [1 mark]  - On heating, the bimetallic strip expands and bends away from the terminal thus breaking contact with the terminal connected to the battery and thus breaking the circuit. [1 mark]  - On cooling, the bimetallic strip contracts and becomes straight again thus making contact once again with the terminal connected to the battery and switching on the lights. [1 mark]	3
Q.160	(a) 1 mark each for the following:  - In figure 1, the indicator light will go off and on as the thermostat controlling the heating of the coils cuts off and on.  - In figure 2, the indicator light will go off only when the main switch is put off.  (b) The difference in the connections will not change the heating of the iron as the thermostat will be controlling the heating of the coils by cutting off and on, though the light remains on continuously.  (c) The earthing wire protects against electric shocks.	4



## 19. NATURAL RESOURCES

Q.No	Question	Marks
<b>Multiple Choice Question</b>		
Q.161	<p>Here is a solar light installed on the roof of a house in New Delhi (latitude of <math>28.70^{\circ}</math> N and longitude of <math>77.10^{\circ}</math> E)</p>  <p>Towards which direction is the solar panel likely to be tilted for maximum conversion of solar energy to electricity in a day?</p> <p>A. North B. South C. East D. West</p>	1
Q.162	<p>The graph below shows the extinction rates of different vertebrate species from the year 1500- 2014.</p> <p><i>(Note: The extinction rate is the percentage of species that would go extinct over a period of time.)</i></p>	1

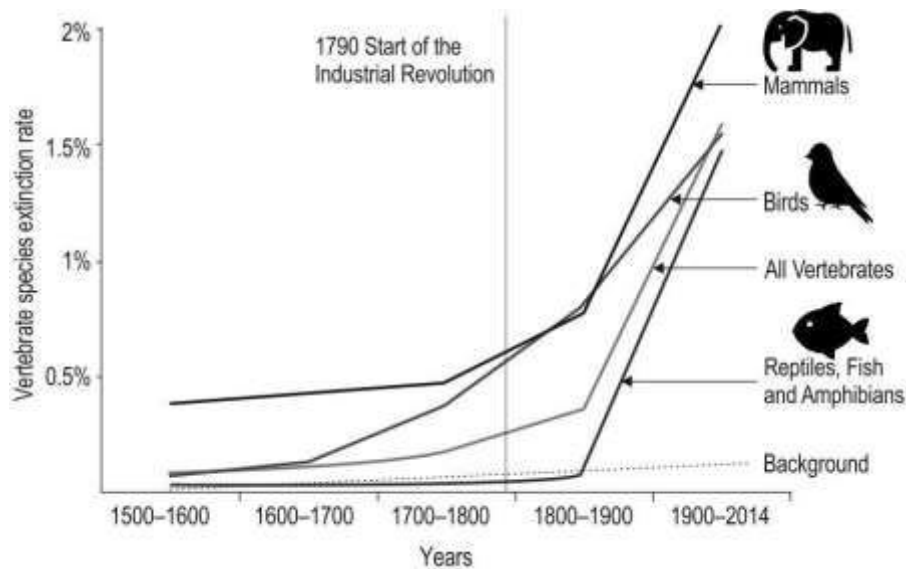

Based on the graph, which of the following is TRUE?

- A. Species flourished before the industrial revolution.
- B. Most species were extinct between the year 1500 to 1600
- C. There was an increase in the number of species between the years 1800 to 2014
- D. Reptiles, fish and amphibians are always fewer in number as compared to other vertebrates.

Q.163

Here is a schematic diagram of trees growing in monoculture (trees of the same species growing together) and polyculture (trees of different species growing together).

1

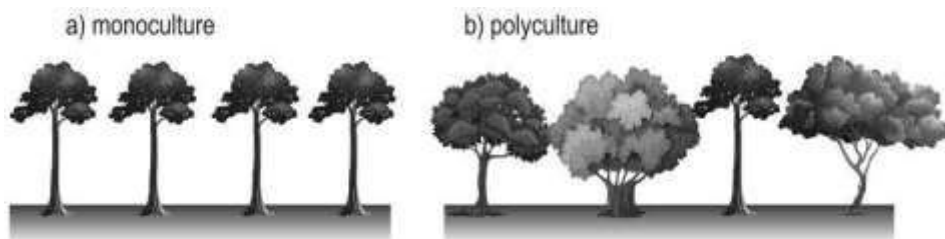

In monoculture, the trees have a uniform canopy while in polyculture the trees have a species-specific canopy.

But now the forest areas are cleared to grow a single type of crop such as teak year after year for the production of teakwood.

What can such a type of practice do?

- A. Reduce global warming
- B. Promote biodiversity
- C. Amplify global warming
- D. Impede biodiversity

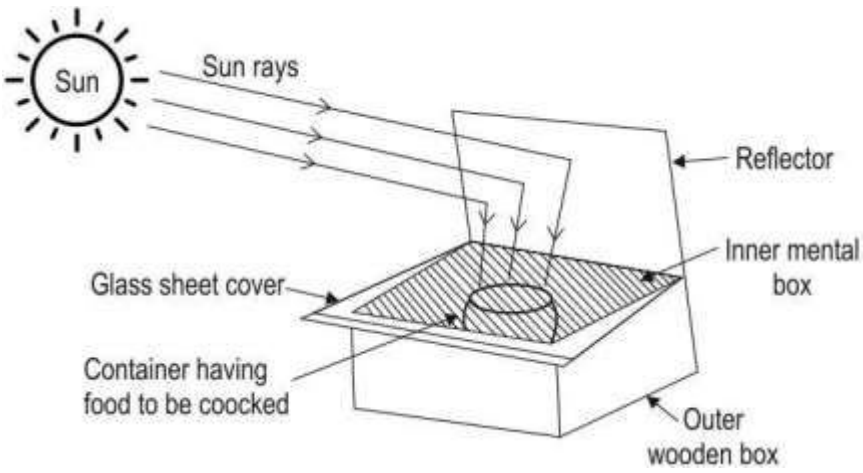
<p>Q.164</p>	<p>Shown below is a labelled diagram of a solar cooker.</p>  <p>Which is MOST likely the correct reason for covering the solar cooker with a thick glass sheet?</p> <p>A. To reflect sunlight better  B. To reflect harmful uv rays  C. To prevent heat from escaping  D. To prevent the absorption of heat</p>	<p>1</p>
<p>Q.165</p>	<p>Compostable plastics are biodegradable in conditions conducive to composting. Other biodegradable plastics degrade when buried in the soil (in landfills or anaerobic digestors).</p> <p>Which of the following statements is likely to be true?</p> <p>P) Compostable is always biodegradable.  Q) Biodegradable is not always compostable.</p> <p>A. Only P  B. Only Q  C. Both P and Q  D. Neither P nor Q</p>	<p>1</p>
<p>Q.166</p>	<p>Diclofenac is a drug that is administered to cattle that undergoes the process of biological magnification.</p> <p>Which of the following is likely to have the highest amount of the drug in it?</p> <p>A. Cheetah  B. Vultures  C. Goats  D. Foxes</p>	<p>1</p>

Free response question/Subjective Question

Q.167

The diagram below represents a pyramid of numbers for a food chain.

3

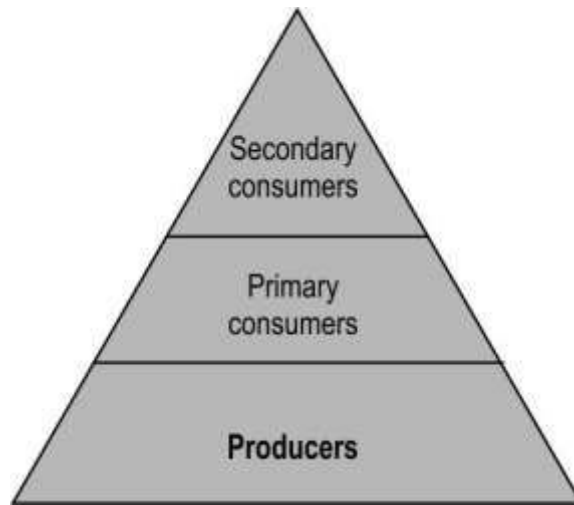

- (a) Why do successive trophic levels in this taper as we move from bottom to top?
- (b) What is the average proportion of energy expected to be transferred from one trophic level to the next?
- (c) Cite an example of an inverted pyramid of numbers.

Q.168

On an overnight train journey Varun found tea being served in various kinds of cups as shown below:

2



Earthen cup



Plastic cup



Paper cup



Ceramic cups

- (a) Which kind of tea cup is most harmful for the environment and why?

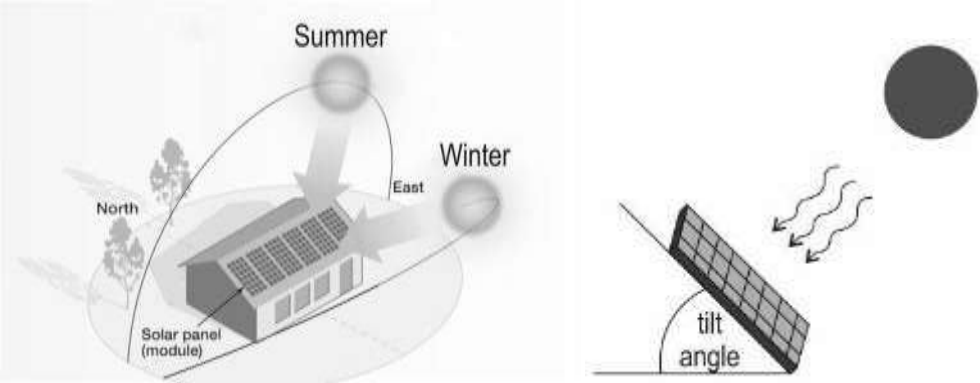
	(b) Which one of the tea cups is made from the most environment friendly material and why?	
Q.169	The 10% law of energy transfer between trophic levels talks of only 10% of the energy being transferred from one trophic level to the next.  In what form is this energy transferred from one trophic level to the next?	1
Q.170	Solar cell panels are used to generate electricity using solar energy. The energy output of the solar cells is maximum when sunlight falls perpendicular to the solar panels.  Given below is a schematic diagram of a setup of solar panels on a roof and a diagram showing the tilt angle.  	2
	(a) In which hemisphere is this setup likely to be located?  (b) If the setup is located closer to the equator, how would the tilt angle change?	
Q.171	Ritu bought two sets of single-use disposable cups. One of them is made of Styrofoam (thermocool), which is obtained from petroleum products. The other one is made of sugarcane waste.  Which of them is likely to remain in the environment or landfill longer? Why?	1
Q.172	India has adopted Bharat Stage (BS) Emission Standards since 2000, modelled on Euro norms. The Bharat Stage emission standards regulate tailpipe emissions of air pollutants including particulate matter (PM), oxides of Nitrogen (NO <sub>x</sub> ) as well as carbon monoxide (CO), and hydrocarbons (HC).  Bharat stage standard III (BS III) was introduced in the year 2010, and Bharat stage standard IV (BS IV) was introduced in the year 2017.  Here is a comparison of petrol and diesel emission norms.	4

**PETROL EMISSION NORMS**

Norm	CO	HC	NOX	HC+NOX	PM
BS-III	2.30	0.20	0.15	-	-
BS-IV	1.00	0.10	0.08	-	-
Euro-VI	1.00	0.10	0.06	-	0.005

**DIESEL EMISSION NORMS**

Norm	CO	HC	NOX	HC+NOX	PM
BS-III	0.64	-	0.50	0.56	0.05
BS-IV	0.50	-	0.25	0.30	0.005
Euro-VI	0.50	-	0.06	0.17	0.005

All figures in g/km Source: Indian Emissions Regulations/ARAI

- (a) How can the use of fuel non-compliant with emission standards contribute to global warming and toxicity to the environment?
- (b) Can a diesel vehicle purchased in the year 2014, with an engine that has passed BS III be used in the year 2020? Justify
- (c) Petrol cars fitted with particulate filters are among the cleanest cars. How does this satisfy the petrol emission norm?

Q.173

An image of a water reservoir belonging to the Dholavira civilization (3000 BCE to 1700 BCE) is given below.



- (a) How would this water reservoir system have helped in water conservation?
- (b) Give two examples of how water stored in the ground can help to reduce water pollution.

Q.174

The drug Diclofenac was administered to the cattle as an anti-inflammatory drug to ease pain and aches. When these animals died, the carcasses of dead cattle that were administered the drug were disposed off in the wastelands.

The graph given below gives information on the effect of the drug Diclofenac on the population of vultures.

3

2

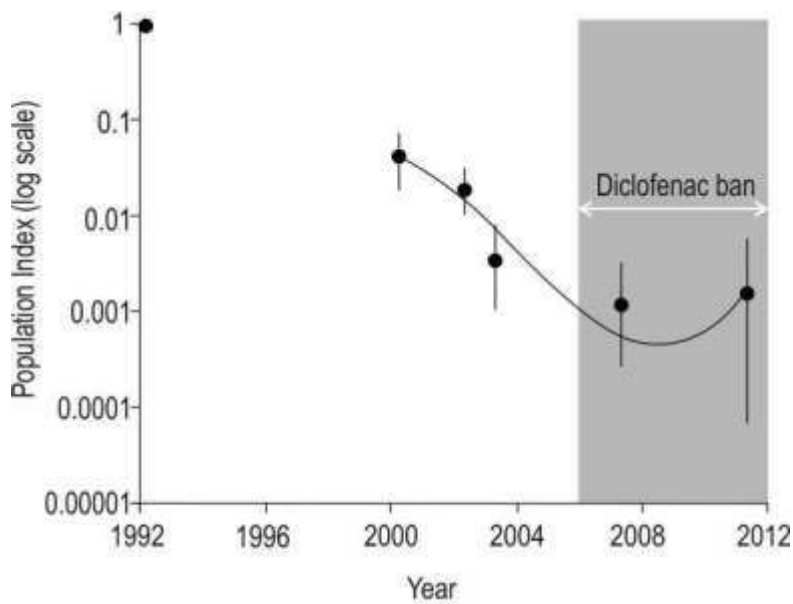

- (a) How did the usage of such drugs impact the population of vultures?  
 (b) What could be the effect on the vultures after the ban of the drug Diclofenac?

Q.175 A food web consists of many interrelated food chains. It represents the feeding relationship between many food chains. An aquatic food web is represented in the image given below.

2

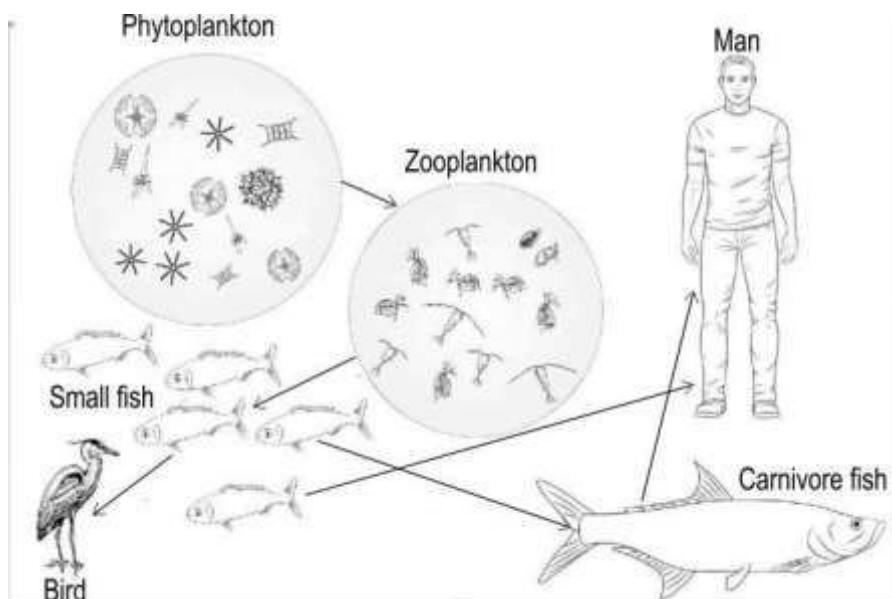

Consider that a dam is constructed across the river where this aquatic food web exists. The small fishes in the river generally travel upstream to lay eggs which was not possible after the construction of the dam.

The population of which organism is MOST likely to increase due to the construction of the dam? Justify.

Q.176 Ratan stays in New Delhi, which is at a latitude of  $28^\circ$  N. He wants to design a house such that maximum sunshine is obtained throughout the day.

2

	<p>What direction should his windows face for maximum availability of sunlight during the daytime?</p> <p>Justify your answer.</p>											
Q.177	<p>Both biogas and coal are fuels that can be used for energy production.</p> <p>Write one advantage that biogas has over coal.</p>	1										
Q.178	<p>In a solar furnace, the temperature at the focal point may reach 3,500 °C (6,330 °F), and this heat can be used to generate electricity, melt steel and so on.</p> <p>(a) Which commonly used solar equipment works on a similar principle as that of the solar furnace?</p> <p>(b) Describe two features of the equipment mentioned in answer (a) that enable it to gather and trap heat.</p> <p>(c) Which of the places are best suited to use solar furnaces to generate electricity?</p>	4										
Q.179	<p>Most of the plastic articles that we use in our daily life are made from chemicals obtained from petroleum. After use, most of this plastic ends up as waste in landfills or the oceans. Nowadays, many products are made of plastic obtained from natural, plant-based products such as corn starch.</p> <p>What is likely to be the main difference between these two types of plastics?</p>	1										
Q.180	<p>Straws made from palm leaves are organic. These single-use drinking straws are made of dried leaves that naturally fall to the ground.</p> <p>Paper straws are made of food-grade paper and water-based adhesive or glue. Both paper straws and palm leaf straws are biodegradable.</p> <p>(a) State an advantage of palm leaf straws over paper straws.</p> <p>(b) Why can single-use palm straws be recycled again?</p>	2										
Q.181	<p>Tina is trying to make responsible choices by following the 5R's of waste management.</p> <p>She has categorised her activities in the table given below.</p> <table border="1" data-bbox="268 1675 1316 2027"> <thead> <tr> <th></th> <th>Activity</th> </tr> </thead> <tbody> <tr> <td><b>Reduce</b></td> <td>use public transport</td> </tr> <tr> <td><b>Reuse</b></td> <td>discoloured water bottle used to keep water in the refrigerator</td> </tr> <tr> <td><b>Recycle</b></td> <td>a broken cup used as a planter</td> </tr> <tr> <td><b>Repurpose</b></td> <td>old tyres made into stools</td> </tr> </tbody> </table>		Activity	<b>Reduce</b>	use public transport	<b>Reuse</b>	discoloured water bottle used to keep water in the refrigerator	<b>Recycle</b>	a broken cup used as a planter	<b>Repurpose</b>	old tyres made into stools	3
	Activity											
<b>Reduce</b>	use public transport											
<b>Reuse</b>	discoloured water bottle used to keep water in the refrigerator											
<b>Recycle</b>	a broken cup used as a planter											
<b>Repurpose</b>	old tyres made into stools											

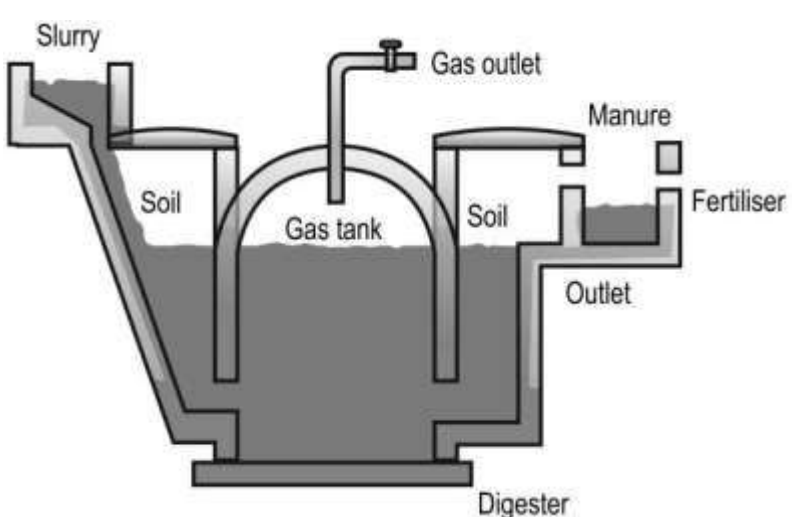

	<b>Refuse</b>	carry steel straw to drink tender coconut or juice outside	
	Which of the activities is placed under the wrong heading? Where should it be placed and Why?		
Q.182	Forests and sanctuaries are usually rich in biodiversity and are biodiversity hotspots. Can man-made lakes be considered biodiversity hotspots? Justify the statement.		1
Q.183	In a national park, domestic animals from the nearby villages were sent to graze regularly. Over a period of time, the population of big cats or carnivores in the national park were found to decline. What is likely to have led to a decrease in the number of big cats in this national park?		2
Q.184	Small ponds, created by building check dams across streams, dry up a few months after the rainy season. This is due to loss of water by evaporation and by seepage into the soil. Loss of water by which of these methods could actually be beneficial to farmers in the dry season? Justify your answer.		2
Q.185	Nuclear power plants are typically constructed away from densely populated urban areas. Mention any TWO reasons why.		2
Q.186	Here's a schematic diagram of a biogas plant. 		2
	(a) What is the main product obtained at the end of the process of digestion? (b) State one modification that can be made in the biogas plant which will prevent the generation of the major product identified in (a). Justify your answer.		

Q.187	(a) Even though nuclear energy doesn't produce excess greenhouse gases like other sources of energy, it is not considered a clean form of energy. Justify the statement.  (b) In TWO points explain how nuclear reactions help in the production of energy in nuclear reactors.	3
-------	---	---

## Answer Key and Marking Scheme

Q.No	Answers	Marks
Q.161	B. South	1
Q.162	A. Species flourished before the industrial revolution.	1
Q.163	D. Impede biodiversity	1
Q.164	C. To prevent heat from escaping	1
Q.165	C. Both P and Q	1
Q.166	B. Vultures	1
Q.167	(a) because the number of organisms in each level keeps reducing at successive trophic levels  (b) 10%  (c) 1 mark any correct answer such as: - an ecosystem with parasites - an ecosystem of saprophytes  [Accept any other valid answer]	3
Q.168	(a) 0.5 marks each for name and reason: - plastic - because plastic is non-biodegradable  (b) 0.5 marks each for name and reason: - earthen cups - because they are made from naturally occurring material	2
Q.169	chemical energy	1
Q.170	(a) This setup is likely to be located in the Northern Hemisphere.  (b) If the setup is located closer to the equator, the tilt angle would decrease.	2
Q.171	(a) 0.5 marks for each of the following:	1

	<ul style="list-style-type: none"> <li>- Styrofoam is likely to remain in the environment or landfill longer.</li> <li>- Styrofoam is not biodegradable.</li> </ul>	
Q.172	<p>(a) 1 mark for each point</p> <ul style="list-style-type: none"> <li>-A non-compliant fuel when burnt releases oxides of sulphur, nitrogen and carbon dioxide in high amounts. All three are greenhouse gases, and high environmental concentration leads to increased global warming.</li> <li>-Besides global warming, oxides of Nitrogen and Sulphur are toxic to the environment by causing acid rain.</li> </ul> <p><i>(accept any other valid answers)</i></p> <p>(b) The vehicle can be used only if it fulfils the BS-IV diesel emission norms.</p> <p>(c) Particulate filter would filter the particulate matter. Cars that have a particulate filter eliminate particulate emissions into the environment.</p>	4
Q.173	<p>(a) Water reservoir system helps in recharging groundwater. As water seeps into the ground, it recharges the wells and other groundwater sources.</p> <p>(b) 1 mark for each point</p> <ul style="list-style-type: none"> <li>- As it is not stagnant open water, there won't be a breeding ground for mosquitoes in the water.</li> <li>- This water will not come in direct contact with human and animal waste.</li> </ul>	3
Q.174	<p>(a) The usage of drugs like Diclofenac impacted the population of vultures as the vultures fed on the carcass of the cattle, the drug administered in the cattle affected the vultures, thus causing their death.</p> <p>(b) The ban on the drug Diclofenac, would possibly increase the population of vultures</p>	2
Q.175	<p>1 mark for each of the following:</p> <ul style="list-style-type: none"> <li>- The population of zooplankton may increase.</li> <li>- If small fish cannot lay eggs, their rate of reproduction will decline over time, leading to lower consumption of zooplankton.</li> </ul> <p><i>[Accept any other valid answer.]</i></p>	2
Q.176	<p>Ratan's house windows should face South.</p> <p>As Delhi is at 28° N latitude, the sun will always be towards the south of Delhi, and the sunlight will enter the windows facing south throughout the day.</p>	2

Q.177	- Biogas is 75% methane, and burns without creating smoke or particulate matter.	1
Q.178	(a) Solar cooker uses a similar principle as that of a solar furnace.  (b) 1 Mark for each point:  - A solar cooker has mirrors that reflect light falling on it to a single focal point.  - A solar cooker has blackened inner surfaces in the wooden box of the solar cooker to absorb radiations from the beam of sunlight.  (c) The places that are best suited to use solar furnaces to generate electricity are the ones that receive steady sunlight throughout the year.  (accept any other valid answer)	4
Q.179	-The plastic made from chemicals obtained from petroleum will be non-biodegradable. The plastic obtained from natural, plant-based products is biodegradable. [1 mark]  <b>OR</b>  Only the plastics obtained from natural products is biodegradable. [1 mark]  (Marks to be given for any other valid answer.)	1
Q.180	(a) The palm leaves are easily available and can be used directly in making palm-leaf straws. To make paper straws, the paper needs to be manufactured first which involves the usage of a lot of water and chemicals that lead to pollution.  (b) Since palm leaves are made from a natural source, they are biodegradable and can be recycled.	2
Q.181	<i>(1 mark for each point)</i>  - A broken cup used as a planter is misplaced under the recycle column.  - This has to be placed under the repurpose column.  -It is a new product, but it is not melted/remoulded, it is just used for a different purpose.	3
Q.182	- Yes.  - The man-made lakes have an ecosystem with many species of animals and plants in them. The range of different life forms represents a biodiversity hotspot.	1

	<i>(No marks are to be awarded without justification)</i>	
Q.183	<p>1 mark for each of the following:</p> <ul style="list-style-type: none"> <li>- Due to cattle grazing in the national park, the other wild herbivores would not get sufficient food/plants to graze on, which is likely to cause a decline in their population.</li> <li>- A decline in the herbivore population directly impacts the population of big cats or carnivores.</li> </ul>	2
Q.184	<ul style="list-style-type: none"> <li>- Seepage of water into the soil could be beneficial in the dry season. [1 mark]</li> <li>- Seepage of water into the soil recharges the ground water which can be used in the dry months. [1 mark]</li> </ul>	2
Q.185	<p><i>[1 mark each for any two of the following points]</i></p> <ul style="list-style-type: none"> <li>- Minimizes the risk of radiation exposure in densely populated areas.</li> <li>- Facilitates more efficient evacuation plans in case of emergencies.</li> <li>- Mitigates noise disturbances to nearby residents.</li> <li>- Nuclear plants require extensive land building facilities and safety buffers.</li> </ul> <p><i>[Accept any other valid answer]</i></p>	2
Q.186	<p>(a) Methane is the main product obtained at the end of the process of digestion.</p> <p>(b)</p> <ul style="list-style-type: none"> <li>- Modification: Adding an inlet of air into the digester will prevent the generation of methane. <i>[0.5 marks]</i></li> <li>- Justification: Methane is produced by anaerobic bacteria in the absence of air, so adding an inlet of air will allow air to enter, thus, eliminating the anaerobic condition inside the digester. <i>[1 mark]</i></li> </ul>	2
Q.187	<p>(a) Nuclear energy produced does not pollute with greenhouse gases like other sources of energy but used/spent fuel continues to release harmful radiations which results in environmental contamination.</p> <p>(b) 1 mark each for the following points:</p> <ul style="list-style-type: none"> <li>- In nuclear fission, the nucleus of a heavy atom such as uranium/plutonium/thorium is bombarded with low-energy neutrons and gets split into lighter nuclei.</li> </ul>	3

	- An enormous amount of energy is released during the process which is used in the production of steam and the generation of electricity.	
--	---	--

**Ei**



---

**Central Board of Secondary Education  
Shiksha Sadan, 17, Rouse Avenue,  
New Delhi-110002**