

# Chapter 1

## Basic of Computer Organisation

New syllabus  
2023-24

# Computer Science

## Class XI (As per CBSE Board)

Visit : [python.mykvs.in](http://python.mykvs.in) for regular updates

# Basics of Computer Organisation

---

## Introduction to computer system

A computer is an electronic device, under the control of instructions stored in its memory that can accept data (input), process the data according to specified rules (Program) on processor & produces information (output), and store the information for future use.

## Data vs Information

**Data** are raw numbers or other findings which, by themselves, are of limited value.

**Information** is data that has been converted into a meaningful and useful context.

**Computers are being used extensively nowadays in everyday life/every field**

**In the form of laptop, desktop, smartphone, gadgets etc**

Visit : [python.mykvs.in](http://python.mykvs.in) for regular updates

# Basics of Computer Organisation

---

## Introduction to computer system

### Advantages of computer

- Speed
- Accuracy
- Huge storage
- Versatility
- Tirelessness

### Disadvantages of computer

- Data security issue
- Computer crimes
- Health risk
- Bad impact on environment if not properly disposed off



Visit : [python.mykvs.in](http://python.mykvs.in) for regular updates

# Basics of Computer Organisation

---

## Introduction to computer system

Any digital computer performs five functions in gross term.

1. Take data as input
2. Stores data/instructions
3. Process those stored data
4. Generate the output
5. Control all above steps



Visit : [python.mykvs.in](http://python.mykvs.in) for regular updates

# Basics of Computer Organisation

---

## Introduction to computer system

**Computer Components** Any kind of computers consists of HARDWARE AND SOFTWARE.

**Hardware:** Computer hardware is the collection of physical elements/parts that constitutes a computer system, such as the monitor, mouse, keyboard, computer data storage, hard drive disk (HDD), system unit (graphic cards, sound cards, memory, motherboard and chips), etc. all of which are physical objects & can be touched.

**Software :** Software is a generic term for organized collections of computer data and instructions, often broken into two major categories: system software that provides the basic nontask-specific functions of the computer, and application software which is used by users to accomplish specific tasks.

Visit : [python.mykvs.in](http://python.mykvs.in) for regular updates

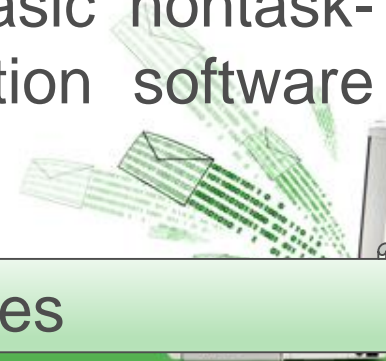

# Basics of Computer Organisation

## Introduction to computer system

## Functional components of a computer

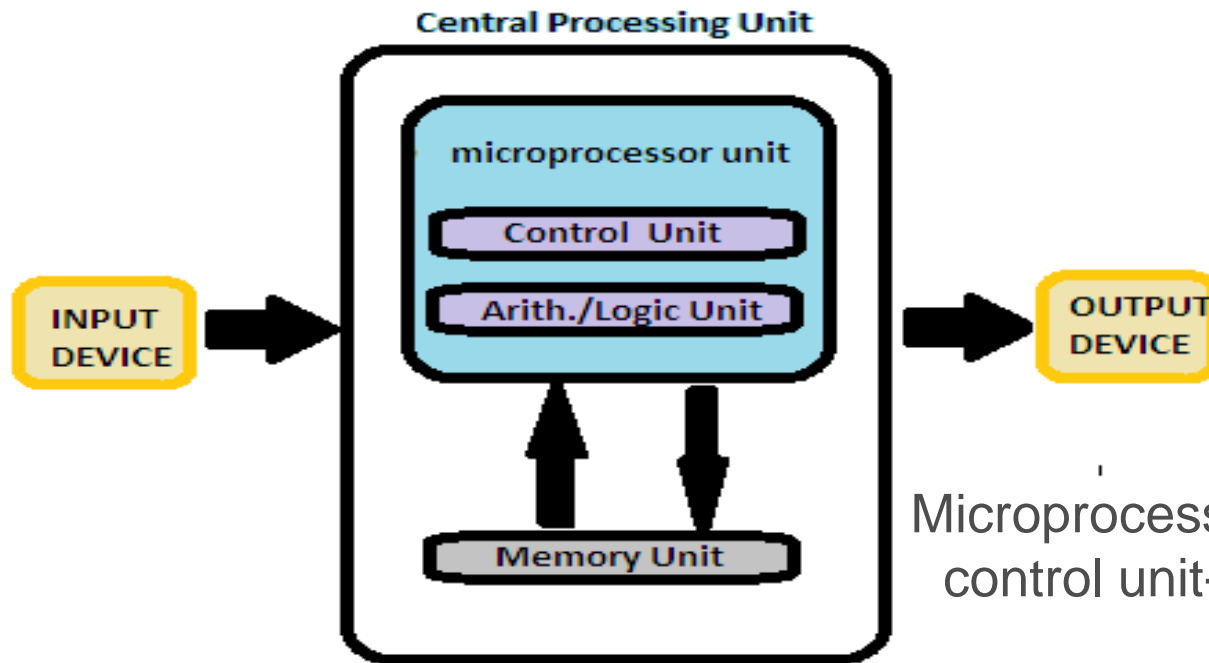

Von Neuman Computer Architecture

Microprocessor unit(mpu) = (CU+ALU)  
control unit+arithmetic / logical unit

**CPU=MPU+Memory Unit**

Visit : [python.mykvs.in](http://python.mykvs.in) for regular updates

# Basics of Computer Organisation

---

## Hardware

### Input/Output Units

#### Input Unit

A device through which data and programs from the outside world enter the computer system.

#### Output unit

A device through which results stored in the computer memory are made available outside the computer system.



Visit : [python.mykvs.in](http://python.mykvs.in) for regular updates

# Basics of Computer Organisation

## Hardware

**Central processing unit** – Comprises three parts

### 1. Arithmetic/Logic Unit

Performs basic arithmetic operations such as addition and subtraction  
Performs logical operations such as AND, OR, and NOT. Most modern ALUs have a small amount of special storage units called **registers** that can be accessed faster than main memory.

### 2. Control unit

It organizes the computer to work computer as single unit & generates control signals for various devices regarding read/write or execute operation

### 3. Memory

A collection of cells, each with a unique address

Most computers are byte-addressable

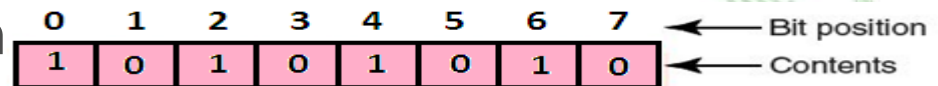

Visit : [python.mykvs.in](http://python.mykvs.in) for regular updates



# Basics of Computer Organisation

**Memory Units** – How much memory is required for a file/data/program etc. is measured by memory units. Following are the memory units.

UNIT	STORAGE	ABBREVIATION
Bit	Binary Digit, Single 1 or 0	B
Nibble	4 bits	-
Byte/Octet	8 bits	B
Kilobyte	1024 bytes	KB
Megabyte	1024 KB	MB
Gigabyte	1024 MB	GB
Terabyte	1024 GB	TB
Petabyte	1024 TB	PB
Exabyte	1024 PB	EB
Zettabyte	1024 EB	ZB
Yottabyte	1024 ZB	YB

Visit : [python.mykvs.in](http://python.mykvs.in) for regular updates

# Basics of Computer Organisation

## Memory Types

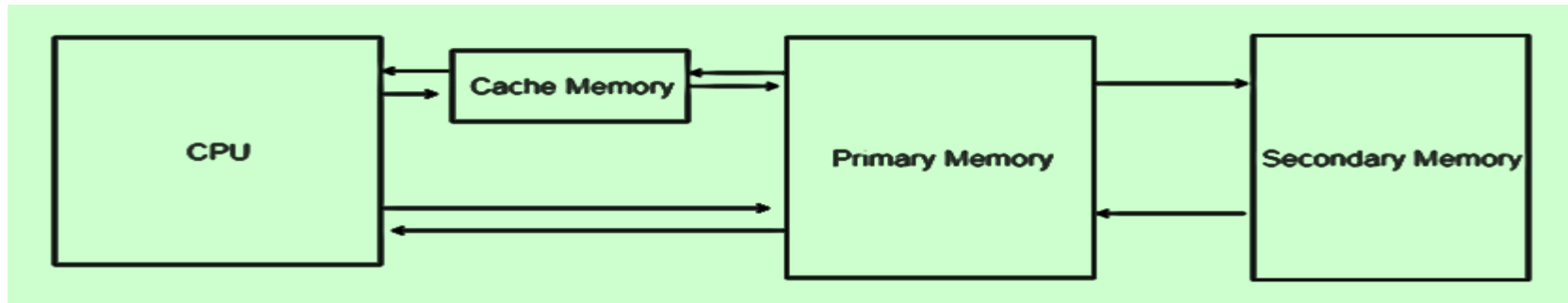

### \*Primary Memory

**Random Access Memory (RAM)** - is a type of volatile memory that stores information on an integrated circuit which holds the data mainly when the program is being executed by the CPU. As it is volatile in nature so it can't store data permanently.

**Read Only Memory (ROM)** - a non-volatile memory chip in which data are stored permanently, and can not be altered by

Visit : [python.mykvs.in](http://python.mykvs.in) for regular updates

**Secondary memory.** A storage, which supplements the main

# Basics of Computer Organisation

---

**Cache Memory** - is the volatile computer memory which is very nearest to the CPU, so also called CPU memory, and is between CPU and RAM all the Recent Instructions are Stored into the Cache Memory. It is the fastest memory that provides high-speed data access to a computer microprocessor.



Visit : [python.mykvs.in](http://python.mykvs.in) for regular updates

# Basics of Computer Organisation

## Difference between RAM and ROM

RAM	ROM
1- Used in the computer's regular operations, after loading the OS.	Used mostly in a computer's start-up process.
2- With RAM, writing data is a fast process.	Writing data to ROM is very slow.
3- RAM is a type of volatile memory, meaning the stored data is lost when powering off.	ROM is a type of non-volatile memory, meaning that the data will not be lost when power is removed.
4- A RAM chip can store quite a lot of data, up to 16 GB.	ROM chips usually store only a few megabytes of information, around 4 MB per chip.
5- There are two main types of RAM: dynamic (DRAM) and static (SRAM).	ROM types include EPROM, EEPROM, PROM and Mask ROM.
6- Example of RAM: RAM chips like 2GB, 4GB, 8GB etc of different companies like Corsair, Kingston etc.	Example of ROM: cartridge in video game consoles, computer BIOS.

Secondary Storage  
Magnetic

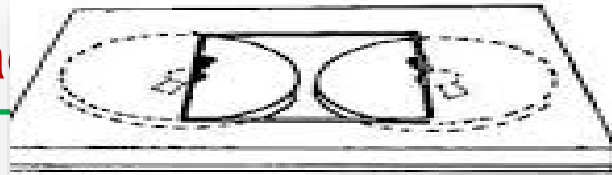

Visit : [python.mykvs.in](http://python.mykvs.in) for regular updates

# Basics of Computer Organisation

## Secondary Storage Devices

### Hard disk

Fixed Head HDD / Movable head HDD

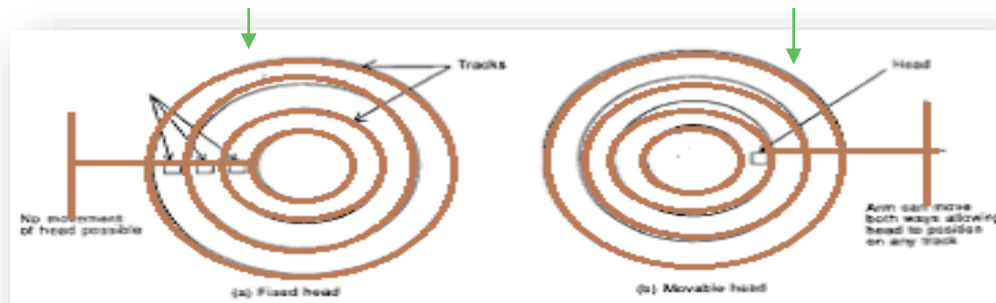

A hard disk is a set of stacked disks. Each disk has data recorded electromagnetically in concentric circles, or tracks, on the disk

### Hard Drive Types

1. Parallel Advanced Technology Attachment (PATA)
2. Serial ATA (SATA)
3. Small Computer System Interface (SCSI)
4. Solid State Drives (SSD)

Upto 12 TB sized HDD is available in the market



Visit : [python.mykvs.in](http://python.mykvs.in) for regular updates

# Basics of Computer Organisation

## Input Devices

Input devices can send data or information to a computer or another device.

**Keyboard:** It is an input device which sends data in to the computer. The data send depends on the key pressed by the user.

**Mouse:** A mouse is a small handheld input device which controls a cursor in a graphical user interface. It can move and select text, files, folders etc. on our computer according to the user input.

**Scanner:** Scanner optically reads and document, file or image and then changes it into digital signal and sends to the computer.

**OMR:** optical mark recognition/ reader, is used to read marks on a document and send them to computer.

**OCR:** OCR stands for optical character Recognition, is an input device which reads printed text and sends that to computer.

**MICR:** Magnetic Ink Character Reader is an input device which generally finds application is banks to process cheques.

**Microphone:** it receives audio generated by some input source and sends it to a computer.

**Webcam:** it sends the captured images to a computer.

**Graphics Tablets:** This input device is used to draw using hand.

**Trackballs:** an upside down mouse ,encased within a socket. Is a cursor control device.

**Barcode reader:** It is used to read the barcode of various items and feed the same to computer.

**Gamepad:** Also known as joy pad is the input controller for video games.

**Joystick:** these input devices are used to control video games.



Visit : [python.mykvs.in](http://python.mykvs.in) for regular updates

# Basics of Computer Organisation

---

## Output Devices

A device that can receive data from computer or another device and create output with that data is called output device. Examples of various output devices are as :

**Monitor:** A monitor is an output device that is responsible for receiving data from a computer and displaying that information as text or images for users to see.

**Speakers:** Receives sound signal from a computer and then plays that sound signal and thus we hear songs or music or any other audio.

**Projector:** Gets data from a computer and displays or projects the same information onto a screen or a wall. Projector cannot directly accept data from a user and send that data to another device.



Visit : [python.mykvs.in](http://python.mykvs.in) for regular updates

# Basics of Computer Organisation

## Both Input / Output Devices

An input/output device is capable of receiving data from users or another devices and also sending data to another devices or computers. That means a devices which can be used as both input device and output device are called Input / Output (I/O) devices. Some examples of input/output devices are as:

**USB drive:** Also known as pen drive or flash stick works as both input device to computer and as an output device. USB drives receive or save data from a computer as an input and it can also send data to a computer or another device.

**Facsimile:** Facsimile or FAX machine has a scanner which is an input device and a small printer to provide output.

**Modems:** It is used to transmit and receive data from one computer to another computer or other devices using telephone lines

**CD-RW drives and DVD-RW drives:** Receives data from a computer as input to copy onto and save into writable CD or DVD. We also use CDs or DVDs to transfer data to a computer.

**Touch Screen:** Touch screen is both input and output device. By touching the screen input is provided and being a screen, it is used as an output device.

**Headsets:** Headset consists of speaker as an output device and microphone functions as an input device.

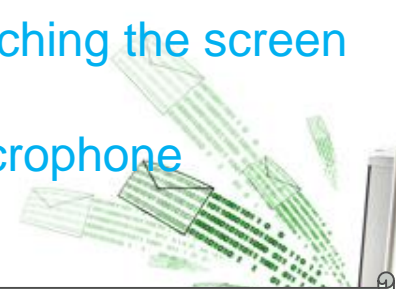

Visit : [python.mykvs.in](http://python.mykvs.in) for regular updates