



केन्द्रीय विद्यालय संगठन
KENDRIYA VIDYALAYA SANGATHAN

आंचलिक शिक्षा एवं प्रशिक्षण संस्थान, मैसूर

**ZONAL INSTITUTE OF EDUCATION AND TRAINING,
MYSURU**

विज्ञान में योग्यता आधारित मूल्यांकन: परीक्षण वस्तुओं की रचना

Competency Based Assessment in Science: Design of test Items

(11.12.2023 -15.12.2023)



सुश्री मीनाक्षी जैन/Ms Menaxi Jain

निदेशक/Director

आंचलिक शिक्षा एवं प्रशिक्षण संस्थान, मैसूर

ZONAL INSTITUTE OF EDUCATION AND TRAINING, MYSURU

CONTENT CREATORS

SL. NO	NAME OF THE TEACHER	Designation	KV WHERE WORKING	REGION
1	Mr Anil Kumar G (ACD)	Principal	NAL Banglore	Banglore
2	Ms Sheeja Menon (RP)	TGT(Sci)	INS Dronacharya	Ernakulam
3	Ms Neeta Wage (RP)	TGT(Sci)	Hebbal	Banglore
	BENGALURU REGION	GROUP 1	GAGANYAAN	
1	Mr Ganapathi T	TGT(Sci)	AFS bidar	Banglore
2	Mr. Hemant Sau	TGT(Sci)	chamraj nagar	Banglore
3	Ms Smriti Kaushik	TGT(Sci)	DRDO	Banglore
4	Ms Mangala Mohan Gaikwad	TGT(Sci)	Raichur	Banglore
5	Ms Seema Saraswat	TGT(Sci)	No. 1 Jalahalli	Banglore
6	Ms Seema Sakhare	TGT(Sci)	Karwar	Banglore
	CHENNAI REGION	GROUP 2	CHANDRAYAAN	
7	Ms Archana Kumari	TGT(Sci)	NO.1 Port Blair	Chennai
8	Ms Mansi Nagar	TGT(Sci)	MINAMBAKKAM	Chennai
9	Mr Aakash Kapoor	TGT(Sci)	Neyveli	Chennai
10	Ms R Rajani Nadar	TGT(Sci)	Nagercoil	Chennai
11	Ms Manita Bharti	TGT(Sci)	AFS Avadi	Chennai
12	Ms S Hemalatha	TGT(Sci)	Anna Nagar	Chennai
13	Ms A M Smita	TGT(Sci)	Ashok Nagar	Chennai
14	Ms Megha Jakhar	TGT(Sci)	DGQA	Chennai
	ERNAKULAM	GROUP 3	MANGALYAAN	
15	Ms Sudha T V	TGT(Sci)	Ezhimala	Ernakulam
16	Ms C V Prasanna	TGT(Sci)	Keltron Nagar	Ernakulam
17	Ms Seena C S	TGT(Sci)	NAD Aluva	Ernakulam
18	Mr. Hemender Singh Yadav	TGT(Sci)	Ramavarmapuram	Ernakulam
19	Ms Sheena C George	TGT(Sci)	RB Kottayam	Ernakulam
20	Ms Shamila S	TGT(Sci)	Pattom Shift I	Ernakulam
21	Dr. Sreejith Gopalan	TGT(Sci)	Kollam	Ernakulam
	HYDERABAD	GROUP 4	ADITYA L-1	
22	Mr Md Abdul I Shariff	TGT(Sci)	CRPF Barkas	Hyderabad
23	Ms Neha Singh	TGT(Sci)	No.1 Golconda	Hyderabad
24	Mr D Raghunath Babu	TGT(Sci)	AFS Hakimpet	Hyderabad
25	Mr Narayan Singh	TGT(Sci)	Mahbubabad	Hyderabad
26	Mr K.Vijay Srinivas	TGT(Sci)	Kakinada	Hyderabad
27	Ms Khileshwari sonwani	TGT(Sci)	Eddumailarum	Hyderabad
28	Ms Sandhya Sharma	TGT(Sci)	Nellore	Hyderabad
29	Ms G Mercy Sulochana	TGT(Sci)	No.2 Srivijaynagar	Hyderabad

LIST OF CONTENTS

S.NO .	सूची / INDEX	PAGE NO.
1	MESSAGE FROM DIRECTOR	4
2	MESSAGE FROM ACD	5
3	TEST ITEMS – CLASS – X	7-94
4	TEST ITEMS – CLASS – IX	96-171
5	TEST ITEMS – CLASS – VIII	173-249
6	TEST ITEMS – CLASS – VII	251-311
7	TEST ITEMS – CLASS – VI	313-374

MESSAGE FROM THE COURSE DIRECTOR



It is with pride that I announce the publication of our COMPETENCY BASED TEST ITEMS for Classes VI - X, SCIENCE for the session 2023-24. I believe that this effort will indeed help teachers and students for attaining contemporary skills to face the challenges in a better way. Our collective vision is to empower all students with the tools for success and intellectual growth.

With utmost dedication TGT- SCIENCE of Bengaluru, Chennai, Ernakulam & Hyderabad regions of Kendriya Vidyalaya Sangathan have invested their knowledge, expertise, and passion into meticulously crafting these competency-based test items to support and devise assessment strategies to equip and empower the students. This material is an ideal tool in enhancing creative and critical thinking skills which in turns help in building up scientific temperament.

It is with pleasure that I place on record my commendation for the commitment and dedication of the team of teachers which included Mr. ANIL KUMAR G, Associate Course Director & Principal, KV NAL Bengaluru, who has been the backbone of this course. Course coordinator Mr. Dinesh Kumar (Training Associate Physics) of ZIET Mysore whose unstinted efforts and precise planning paved way for the successful attainment of proposed objectives. Resource persons Mrs. Sheeja Menon (TGT- Science), KV Ernakulam region and Mrs. Neeta Wage (TGT- Science), KV Bengaluru region imparted training and guidance for the designing process.

Wishing you all the very best in your academic journey!

MENAXI JAIN

DIRECTOR

ZIET MYSURU

MESSAGE FROM ASSOCIATE COURSE DIRECTOR



"Competency Based Assessment" undoubtedly provide an insight into: -what the learners knows, still need to learn, has learned and where the institution can improve. The five days' workshop conducted from 11.12.2023 to 15.12.2023 at ZIET Mysore for the test item preparation on Competency Based Assessment in Science was undoubtedly inspiring and achieved its desired outcome.

Many educated travelled from different regions of KVS and gathered here for attending the workshop. Their tireless and sincere efforts led to the successful completion of the task. The resource persons Mrs. Sheeja Menon, TGT SCIENCE (ERNAKULAM REGION) and Mrs. Neetha Wage TGT SCIENCE (BANGALORE REGION) were powerful motivators. They had a reservoir of resources at their disposal. All their power filled sessions caught the participants spell bound. Their words have ignited the minds of the participants.

I appreciate their excellent guidance to all the participants throughout this workshop. The entire workshop was a huge success under the watchful eyes of "The Director ZIET Mysore" Ms. Menaxi Jain madam, who is a profound intellectual. Madam's dynamic and effective monitoring triggered the spirit of thy resource persons and participants. I whole heartedly appreciate Madam's constant and powerful guidance at every juncture of the workshop. I also express my deepest gratitude for all staff members of ZIET Mysore, especially the course Coordinator Mr. DINESH KUMAR (TRAINING ASSOCIATE, PHYSICS) for their selfless and timely service. The workshop paved way for us to dive deep into the depth of various competency-based assessment, its relevance in the present-day educational system.

Our students are the greatest beneficiaries of this workshop. This material shall serve as a powerful tool of assessment for the entire country. The entire workshop was an uplifting experience for me

Thank You

Mr. ANIL KUMAR G

ACD & Principal, KV

NAL Bengaluru



MR. DINESH KUMAR
COURSE COORDINATOR & TRAINING ASSOCIATE (PHYSICS)
ZIET MYSURU



MRS. SHEEJA MENON
RP & TGT (SCIENCE)
KV INS DRONARCHARYA
ERNAKULAM REGION





MRS. NEETA WAGE
RP & TGT (SCIENCE)
KV HEBBAL BENGALURU
BENGALURU REGION

CLASS – X

S.NO.	NAME OF THE CHAPTER	PAGE NO.
1	CHEMICAL REACTIONS AND EQUATIONS	7
2	ACIDS, BASES AND SALTS	13
3	METALS AND NON-METALS	18
4	CARBON AND IT'S COMPOUNDS	26
5	LIFE PROCESSES	32
6	CONTROL AND COORDINATION	37
7	HOW DO ORGANISMS REPRODUCE?	43
8	HEREDITY	51
9	LIGHT REFLECTION AND REFRACTION	57
10	THE HUMAN EYE AND COLOURFUL WORLD	64
11	ELECTRICITY	70
12	MAGNETIC EFFECTS OF ELECTRIC CURRENT	78
13	OUR ENVIRONMENT	86

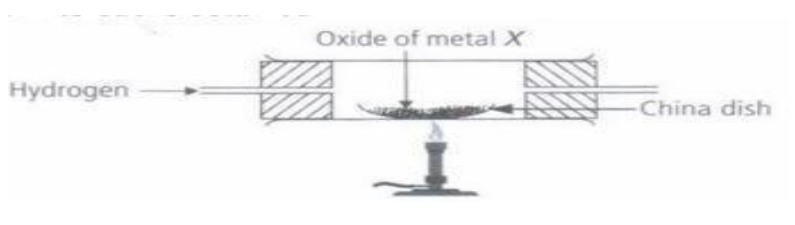
CHAPTER- 1 CHEMICAL REACTIONS AND EQUATIONS

Q NO	SECTION A	MARKS
1	<p>When green coloured ferrous sulphate crystals are heated, the colour of the crystal changes because</p> <p>(a) it is decomposed to ferric oxide (b) it loses water of crystallization (c) it forms SO₂ (d) it forms SO₃</p>	1
2	<p>A substance “M” which is a group 2 element is used intensively in the cement industry. This element is present in bones also. On treatment with water, it forms a solution which turns red litmus blue. Element “M” is:</p> <p>(a) Cu (b) Ca (c) Na (d) Al</p>	1
3	<p>When dry hydrogen is passed over a heated oxide of metal “X” using the apparatus shown below, a reddish-brown residue is obtained.</p>  <p>The reddish -brown residue could be:</p> <p>(a) Copper (b) Lead (c) Silver (d) Zinc</p>	1
4	<p>Which of the following reactions is a displacement reaction?</p> <p>(a) CaO + H₂O → Ca (OH)₂ (b) MgCO₃ → Mg+CO₂ (c) Mg + CuSO₄→ MgSO₄ + Cu (d) H₂ + Cl₂→ 2HCl</p>	1
5	<p>What will be the colour of the precipitate obtained, when a student mixed the solutions of potassium iodide and Lead (II) nitrate.</p> <p>(a) white (b) grey (c) yellow (d) bluish</p>	1
6	<p>Consider the following reaction:</p> $\text{BaCl}_2 + \text{Na}_2\text{SO}_4 \rightarrow \text{BaSO}_4 + 2\text{NaCl}$ <p>Which will give a precipitate in the reaction.</p> <p>(a) BaCl₂ (b) BaSO₄ (c) Na₂SO₄ (d) NaCl</p>	1
7	<p>Assertion (A): Chemical reaction changes the physical and chemical properties of a substance.</p>	1

	Reason (R): Chemical change involves a change in the chemical composition of matter and a new substance is formed.	
8	Assertion (A): Lead nitrate when heated gives lead oxide, nitrogen dioxide and oxygen. Reason (R): Emission of brown fumes indicates the presence of nitrogen dioxide during decomposition of lead nitrate.	1
SECTION B		
9	Varna mixed some zinc granules with dilute sulphuric acid in a conical flask. She observed that a gas evolved from the flask. What gas evolved and identify the type of chemical reaction involved?	2
10	Decomposition of vegetable matter is an emerging technique for waste management. (a) Name type of chemical reaction is happening here? (b) Give another example of such type of reaction.	2
11	When hydrogen sulphide gas is passed through a blue solution of copper sulphate, a black precipitate of copper sulphide and the sulphuric acid are formed. (a) Write a balanced chemical equation for the same. (b) Identify and define the type of the reaction involved.	2
12	Relate the terms oxidation and reduction with an example for each. What is the term given for such reactions occurring simultaneously in the same reaction?	2
13	Analyze the terms respiration and photosynthesis with respect to the chemical reactions involved.	2
SECTION C		
14	3g of Silver bromide is taken in a China dish and the China dish is placed in sunlight for some time.  <p style="text-align: center;">(a) What will be your observation in this case? (b) Write the chemical reaction involved in the form of a balanced chemical equation. (c) Give any one use of such reactions.</p>	3

15	<p>What happens when a piece of:</p> <p>(a) zinc metal is added to copper sulphate solution?</p> <p>(b) Aluminium metal is added to dilute hydrochloric acid?</p> <p>(c) silver metal is added to copper sulphate solution?</p> <p>Formulate the balanced chemical equation, if the reaction occurs.</p>	3
16	<p>(a) Enlist four observations that help us to determine whether a chemical reaction has taken place.</p> <p>(b) Recall any two conditions which initiate a chemical reaction.</p>	3
SECTION D		
17	<p>Amit observed that, when copper powder is heated in a China dish, the reddish-brown surface of copper powder becomes coated with a black substance.</p> <p>(a) Why is this black substance formed?</p> <p>(b) What is the black substance?</p> <p>(c) Write the chemical equation of the reaction that takes place.</p> <p>(d) How can the black coating on the surface be turned reddish brown.</p> <p>(e) Identify and name this type of reaction.</p>	5
18	<p>Kalpana made the following observations during the reaction of some metals with dilute hydrochloric acid.</p> <p>(a) Silver metal does not show any change.</p> <p>(b) The temperature of the reaction mixture rises when aluminium (Al) is added.</p> <p>(c) The sodium metal reaction is highly explosive.</p> <p>(d) Some gas bubbles are seen when lead (Pb) is reacted with the acid.</p> <p>(e) A white solid found in bones when dropped in water produces a hissing sound.</p> <p>Justify these observations giving suitable reasons</p>	5
SECTION E		
19	<p>The following set up is arranged in a laboratory as shown in the given figure.</p>	4

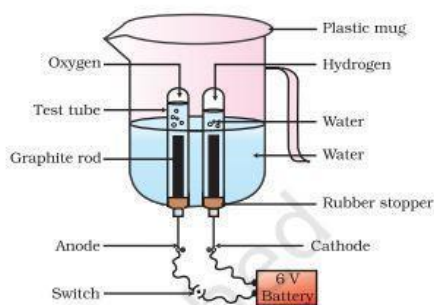

- What is the activity performed in the set up?
- Identify the gas released at different electrodes with reason.
- If a burning candle is brought near to the gas released at positive electrode, what will happen?
- Is the volume of the gas collecting the same in both the test- tubes? Why or why not?

20

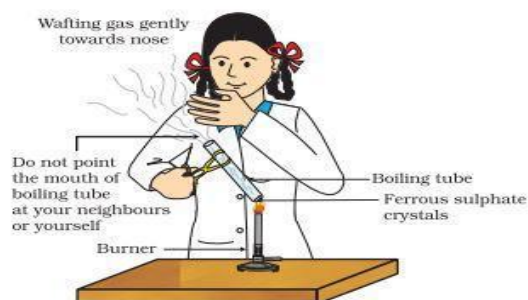

4

In the above image, an experiment is being performed where 3 g ferrous sulphate crystals are taken in a dry boiling tube. The colour of the ferrous sulphate crystals is noted down. After that the boiling tube is heated over the flame of a burner and the colour of the crystal is noted down. Based on the above experiment answer the questions given below:

- What is the colour of the Ferrous sulphate crystals before heating and after heating.
- Name the gases evolved in the above process.
- Establish a balanced chemical reaction for this process.
- Which type of reaction takes place inside boiling tube?

CLASS X ANSWER KEY TOPIC: CHEMICAL REACTIONS AND EQUATIONS

Q NO	SECTION A	MARKS
1	(b)	1
2	(b)	1
3	(a)	1
4	(c)	1
5	(c)	1
6	(b)	1
7	(a)	1
8	(b)	1
	SECTION B	
9	Hydrogen gas, displacement reaction	1+1
10	(a) exothermic reaction/decomposition reaction (b) any one like respiration/burning of natural gas/ any other	1+1
11	(a) $\text{CuSO}_4 + \text{H}_2\text{S} \rightarrow \text{CuS} + \text{H}_2\text{SO}_4$ (b) Double -displacement reaction	1+1
12	Comparison between the term with equation, redox reaction, one chemical reaction showing redox reaction	1+ ½ + ½
13	Respiration- exothermic/ energy released reaction. Photosynthesis- endothermic/energy used. Reactions for both processes.	½ + ½ + ½ + ½
	SECTION C	
14	(a) Decomposition of silver bromide occurs/ splitting of AgBr (b) $2\text{AgBr} \xrightarrow{\text{sunlight}} 2\text{Ag} + \text{Br}_2$ (c) Photography/ black and white photography	1+1+1
15	(a) Zinc displaces copper, $\text{ZnSO}_4 + \text{Cu} \rightarrow \text{CuSO}_4 + \text{Zn}$ (b) Aluminium reacts with acid and hydrogen gas is released. $2\text{Al} + 6\text{HCl} \rightarrow 2\text{AlCl}_3 + 3\text{H}_2$ (c) No reaction will occur.	3
16	(a) Change in state, evolution of gas, change in colour, change in temperature (any 4) (b) Heat, catalyst, temperature, atmospheric pressure (any 2)	½ *4 = 2 , ½ *2 = 1

SECTION D

17	<p>(a) The black substance is formed because copper combines with oxygen.</p> <p>(b) The black substance is copper oxide (CuO).</p> <p>(c) $\text{Cu} + \text{O}_2 \xrightarrow{\text{heat}} \text{CuO}$</p> <p>(d) The black coating on the surface can be turned reddish-brown by-passing hydrogen gas over the hot copper oxide. $\text{CuO} + \text{H}_2 \xrightarrow{\text{heat}} \text{Cu} + \text{H}_2\text{O}$</p> <p>(e) redox reaction</p>	1+1+1+1 +1
18	<p>(a) Silver does not show any characteristics change because silver is less reactive than hydrogen. Thus, it cannot displace hydrogen from dilute hydrochloric acid.</p> <p>(b) The reaction between aluminium (Al) and hydrochloric acid is highly exothermic. Thus, the temperature of the reaction mixture rises.</p> <p>(c) Sodium is a highly reactive metal. It reacts with hydrochloric acid, vigorously forming hydrogen gas and a large amount of heat.</p> <p>(d) When lead reacts with hydrochloric acid, the gas bubbles observed are hydrogen gas. $\text{Pb} + 2 \text{HCl} \rightarrow \text{PbCl}_2 + \text{H}_2$</p> <p>(e) calcium oxide reacts vigorously with water which is an exothermic reaction to form calcium hydroxide.</p>	1+1+1+1 +1
SECTION E		
19	<p>(a) Electrolysis of water</p> <p>(b) Hydrogen at cathode(-ve) and oxygen as anode(+ve)</p> <p>(c) At anode, oxygen is formed which is combustible.</p> <p>(d) No, hydrogen volume is double as due to double the number of hydrogen atoms than the oxygen gas collected at anode.</p>	1+1+1+1
20	<p>(a) Before – green, after- colorless/white.</p> <p>(b) SO_2 and SO_3</p> <p>(c) $2\text{FeSO}_4 \xrightarrow{\text{heat}} \text{Fe}_2\text{O}_3 + \text{SO}_2 + \text{SO}_3$</p> <p>(d) Decomposition reaction</p>	1+1+1+1

CHAPTER -2 ACIDS, BASE AND SALTS

Q NO	SECTION A	MARKS
1	<p>When dry HCl gas is tested with dry blue litmus paper</p> <p>a) blue litmus becomes red color b) blue litmus become pink color c) no color change of litmus paper d) Blue litmus changes to orange</p>	1
2	<p>When a reactive metal reacts with an acid which gas is evolved</p> <p>a) H₂ b) O₂ c) CO₂ d) None of the above</p>	1
3	<p>In which of the following citric acid is found</p> <p>a) Orange b) Vinegar c) Lemon d) Both a and c</p>	1
4	<p>When a solution of HCl is mixed with a solution of NaOH</p> <p>1) Temperature of solution increases 2) Temperature of solution decreases 3) NaCl is formed 4) No reaction</p> <p>a) 2 and 4 b) 1 and 4 c) 1 and 3 d) 2 and 3</p>	1
5	<p>Which of the following is used for removing permanent hardness of water?</p> <p>a) Washing soda b) Sodium Hydrogen Carbonate c) Bleaching powder d) All of the above</p>	1
6	<p>Tooth decay starts when pH of mouth is</p> <p>1) Lower than 5.5 2) Greater than 5.5 3) Lower than 7 4) Greater than 7</p>	1
7	<p>Assertion - If dilute HCl is added slowly while stirring to a small amount of CuO. The solution becomes blue-green.</p> <p>Reason - Blue green color of solution is due to formation of CuCl₂.</p>	1

8	Assertion - When 2 ml of NaOH solution is added to a few pieces of granulated Zn metal in a test tube and then warmed. Sodium zincate is being formed. Reason- Such reactions are possible with all metals.	1
SECTION B		
9	Seema accidentally put buttermilk in a copper vessel. Her mother told her that she shouldn't have stored buttermilk in a copper vessel. Analyse the situation and give possible reasons.	2
10	Is human urine a good or bad conductor of electricity? Justify your answer.	2
11	When we add 2 drops of phenolphthalein solution to 2 mL of dilute NaOH. The solution becomes pink. But when we add dilute HCl to the above solution drop by drop pink colour disappears. Why?	2
12	1) When we heat a few crystals of CuSO_4 in a dry boiling tube, we find water droplets in the boiling tube. Give reasons for your observation. 2) Write the chemical formula for Gypsum.	2
13	Think about a situation where toothpaste is not available. Suggest some alternatives that you can take up instead of toothpaste from your kitchen. Justify your answer	2
SECTION C		
14	Doctors use a white substance for supporting fractured bones in the right position. Identify the substance and give reasons why doctors use it. Write the chemical formula of the material used by the doctors.	3
15	You found that soil in your kitchen garden is not promoting healthy growth of plants even after providing all essential requirements for a plant to grow healthy. Analyse this situation, and suggest a method to identify a possible cause and remedial steps you can take to solve this issue.	3
16	1) Arrange the following in the increasing order of their pH value. Butter milk, milk, Dettol handwash 2) Ramesh was playing near the bee hive. Ramesh was stung badly by a bee as a result his face got swollen and red. How can he get relief in this situation? Illustrate the measure adopted by you in the light of scientific reasons behind it.	3
SECTION D		
17	Ravi wants to make tasty crispy onion pakoras. His friend suggested to use compound X. 1) Write the chemical name of X. 2) Give the chemical equation for the formation of X using NaCl as one of the raw materials. 3) Is ingredient X can be used in antacids? If yes, why?	5

18	<p>When electricity is passed through brine, it decomposes to form compound A, gas B and gas C. Gas B which is produced in the process is used for the manufacture of bleaching powder.</p> <ol style="list-style-type: none"> 1) Identify A and C 2) Identify the products being formed at cathode and anode. 3) Write the chemical equation of the reaction involved. 4) Write the reaction for the formation of bleaching powder. 5) Mention two uses of bleaching powder. 	5
SECTION E		
19	<p>Ravi accidentally put some marble pieces in a test tube having HCl. He then passed the gas evolved through lime water. He found a white precipitate is formed</p> <ol style="list-style-type: none"> 1) Write the chemical equation of the reactions involved in both the cases. 2) Name the white precipitate formed. 3) What happens when excess of evolved gas mentioned above is passed through lime water. Write the reaction involved in this. 	4
20	<p>Alok and Ashish want to prepare a soda acid fire extinguisher. Alok purchased sulphuric acid, wash bottle, ignition tube, tube container.</p> <p>Ashish told him he forgot to purchase one more very important chemical compound to make this extinguisher.</p> <ol style="list-style-type: none"> 1) Identify that important compound which Alok forgot to purchase. Propose the other uses of this component. 2) Propose a design for a soda acid fire extinguisher. 3) Mention the chemical equation involved in this process. 	4

ANSWER KEY CHAPTER- 2 ACIDS, BASES AND SALTS

Q NO	SECTION A	MAR KS
1	d) none of the above	1
2	b) H ₂	1
3	d) Both a and c	1
4	c) 1 and 3	1
5	d) Both a and c	1
6	a) Lower then 5.5	1
7	A	1
8	C	1
SECTION B		
9	Buttermilk is acidic in nature. Acid in buttermilk may react with metal of the container to form toxic salts.	2
10	Urine can be considered as an electrolyte. Different ions are released in human urine throughout the day e.g. Na +, K + and various anionic species	2
11	The colour of dilute NaOH turns pink on adding phenolphthalein. But when HCl is added it starts neutralizing base and gradually solution becomes colorless.	2
12	1) Crystals of copper sulphate lose the water of crystallisation on heating and it becomes anhydrous copper sulphate. The lost water of crystallisation are seen as water droplets on the boiling tube. Where have these droplets come from? 2) CaSO ₄ .2H ₂ O	2
13	Baking soda as it is a non- corrosive basic salt which neutralizes the excess acid being produced in mouth and prevent tooth decay.	2
SECTION C		
14	White substance is Plaster of Paris. Plaster of paris on mixing with water, it changes to gypsum once again giving a hard-solid mass. Chemical formula is CaSO ₄ .1/2 H ₂ O.	3
15	Any logical answer like testing the pH of the soil and correcting it.	3
16	1) Butter milk, milk, Dettol handwash 2) Bee sting leaves an acid which causes pain and irritation. Use of baking soda a mild base on the stung area will neutralise the acid and hence gives relief.	3
SECTION D		
17	Ravi wants to make tasty crispy onion pakoras. His friend suggested him to used baking soda. 1) NaHCO ₃ 2) NaCl + H ₂ O + CO ₂ +NH ₃ → NH ₄ Cl + NaHCO ₃ 3) being alkaline it neutralises excess acid in stomach and provide relief.	5
18	1) A is NaOH and C is H ₂ 2) Cathode – hydrogen gas	5

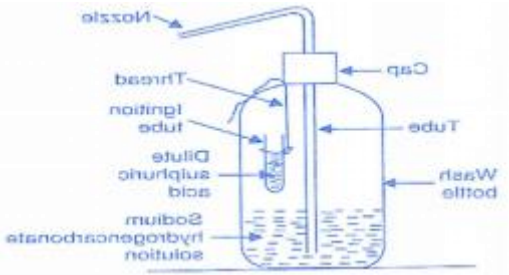
	<p>Anode- chlorine gas</p> <p>3) $2\text{NaCl}(\text{aq}) + 2\text{H}_2\text{O}(\text{l}) \longrightarrow 2\text{NaOH}(\text{aq}) + \text{Cl}_2(\text{g}) + \text{H}_2(\text{g})$</p> <p>4) $\text{Ca}(\text{OH})_2 + \text{Cl}_2 \longrightarrow \text{CaOCl}_2 + \text{H}_2\text{O}$</p> <p>5) It is used for bleaching cotton and linen in the textile industry, for bleaching wood pulp in paper factories As an oxidizing agent in many chemical industries To make drinking water free from germs.</p>	
	SECTION E	
19	<p>1) $\text{CaCO}_3 + 2\text{HCl} \longrightarrow \text{CaCl}_2 + \text{H}_2\text{O} + \text{CO}_2$</p> <p>$\text{Ca}(\text{OH})_2 + \text{CO}_2 \longrightarrow \text{CaCO}_3 + \text{H}_2\text{O}$</p> <p>2) CaCO_3</p> <p>3) White precipitate will disappear as $\text{Ca}(\text{HCO}_3)_2$ is soluble in water.</p> <p>$\text{CaCO}_3 + \text{H}_2\text{O} + \text{CO}_2 \longrightarrow \text{Ca}(\text{HCO}_3)_2$</p>	4
20	<p>Alok and Ashish wants to prepare a soda acid fire extinguisher. Alok purchased sulphuric acid, wash bottle, ignition tube, tube container.</p> <p>Ashish told him he forgot to purchase one more very important chemical compound to make this extinguisher.</p> <p>1) Sodium hydrogen carbonate. Used in baking industry (any other).</p> <p>2) Any logical answer.</p> <p>3) $\text{NaHCO}_3 + \text{H}_2\text{SO}_4 \longrightarrow \text{Na}_2\text{SO}_4 + \text{CO}_2 + \text{H}_2\text{O}$</p>	4
		

CHAPTER- 3 METALS AND NON-METALS

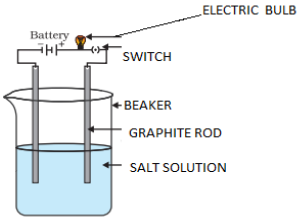
Q NO	SECTION A	MARKS
1	In thermite welding a mixture of and react to produce molten iron metal and large amount of heat is evolved. (a) iron oxide and aluminium powder (b) Iron oxide and zinc powder (c) iron chloride and aluminium powder (d) iron sulphate and copper powder	1
2	Which one of the following statements is FALSE regarding ionic compounds? a) Ionic compounds are water soluble b) Ionic compounds conduct electricity in solid state c) Ionic compounds have high melting points d) Ionic compounds are formed by transfer of electrons between a metal and non-metal atom	1
3	Which of the following pairs will give dis-placement reactions? (a) FeSO ₄ solution and Copper metal (b) ZnSO ₄ solution and Magnesium metal (c) CuSO ₄ solution and Silver metal (d) NaCl solution and Copper metal	1
4	Identify the correct statement from the following. a. Cinnabar is an ore of Iron. b. The impurities found with ore are called anode mud. c. The removal of gangue from ore is called refining of ore. d. Highly reactive metals are extracted by electrolytic reduction method.	1
5	Alloys are homogeneous mixtures of a metal with a metal or non-metal. Which among the following alloys contain non-metal as one of its constituents? (a) Brass (b) Bronze (c) Amalgam (d) Steel	1
6	Observe the diagram given below and identify the aim of this activity. <div style="text-align: center;">  <p>The diagram shows a circuit with a battery, an electric bulb, and a switch. The circuit is connected to a beaker containing a salt solution. A graphite rod is also placed in the solution. Labels include: BATTERY, ELECTRIC BULB, SWITCH, BEAKER, GRAPHITE ROD, and SALT SOLUTION.</p> </div> a) Testing the conductivity of a salt solution b) Electrolysis of water c) Refining of copper d) Formation of hydrogen gas	1

	<p>Q. no 7 to 8 are Assertion - Reasoning based questions. These consist of two statements – Assertion (A) and Reason (R). Answer these questions selecting the appropriate option given below:</p> <p>(a) Both A and R are true and R is the correct explanation of A .</p> <p>(b) Both A and R are true and R is not the correct explanation of A.</p> <p>(c) A is true but R is false.</p> <p>(d) A is False but R is true .</p>	1
7	<p>Assertion (A) : Highly reactive metals are obtained by electrolytic reduction.</p> <p>Reason (R) : In the electrolytic reduction, metal is deposited at the cathode.</p>	1
8	<p>Assertion (A) : Zinc carbonate is heated strongly in presence of excess air to form zinc oxide and carbon dioxide.</p> <p>Reason (R) : Calcination is the process in which a carbonate ore is heated strongly in the absence of air to convert into metal oxide.</p>	1
SECTION B		
9	<p>(a) Calcium start floating when it reacts with water? Give reason for this along with relevant the balanced chemical equation for this phenomenon.</p> <p>(b) Name two metals which do not react with water.</p>	2
10	<p>The molten metal obtained from a chemical reaction is used to seal the cracks in big machines.</p> <p>a) Identify the metal obtained in the molten form and write the name for this type of chemical reaction.</p> <p>b) Write down the balanced chemical equation for the same.</p>	2
11	<p>a) Illustrate the diagram of an activity to show that the rusting of iron needs the presence of two factors.</p> <p>b) Identify these two factors.</p>	2
12	<p>a) Categorise the various balanced chemical equations involved in the formation of zinc from its sulphide ore in correct sequence.</p> <p>b) State the name of the first type of the reaction.</p>	2
13	<p>a) Stainless steel comes under a particular class of substance. Predict the name given to this class of substance and also name the various elements present in stainless steel.</p> <p>b) Give the correct explanation for the particular class of substance mentioned in the sub question a. What these substances are called and how they are useful.</p>	2
SECTION C		
14	<p>A compound X is formed by the reaction between a metal and non-metal which is used for preserving fish and meat and write down its name and chemical formula.</p> <p>b) Illustrate the formation of this compound with the help of diagrammatic representation of electron transfer.</p>	3
15	<p>(a) A metal A, which is used in thermite process, when heated with oxygen gives an oxide B, which is amphoteric in nature? Identify A and B.</p> <p>(b) Write down the reactions of oxide B with HCl and NaOH.</p>	3

16	<p>a) An ionic compound conduct electricity in molten state, but not in solid state. Justify this statement for each part.</p> <p>b) Enumerate the property that is behind the solid nature and high melting point of ionic compound.</p>	3
SECTION D		
17	<p>(a) A reddish-brown metal 'X', when heated in air, gives a black compound 'Y', which</p> <p>when heated in presence of H₂ gas gives 'X' back.</p> <p>Write down the equations showing the formation of Y and X.</p> <p>'X' is refined by the process of electrolysis; this refined form of 'X' is used in electrical wiring.</p> <p>Identify 'X' and 'Y'. Draw a well-labeled diagram to represent the process of refining of X.</p>	5
18	<p>A compound 'P' is used in the guard tube to absorb moisture from the hydrogen chloride gas.</p> <p>a) Identify the compound 'P' and write its chemical formula</p> <p>b) Illustrate the formation of the above-mentioned compound P through diagrammatic representation involving electron transfer.</p> <p>c) Illustrate the formation of Hydrogen chloride gas with the help of labelled diagrammatic representation.</p>	5
SECTION E		
Question No. 19 to 20 are case-based/data -based questions with 2 to 3 short sub-parts.		
19	<p>We already know that as per the reactivity series of metals, the most reactive metals are at the top of the series while the least reactive ones are at the bottom. Metals that are least reactive such as gold, platinum, and silver occur in a free state in the Earth's crust. However, in their ore these metals can be associated with sulphide minerals such as pyrites, chalcopyrite's, etc. However, other low reactive metals such as mercury exist as its sulphide in cinnabar ore.</p> <p>Metals such as zinc and iron, etc., that come in the middle of the series are moderately reactive and occur as their oxides, sulphides and carbonates, in the Earth's crust. For example, zinc occurs as its sulphide in the ore zinc blende and as carbonate in the ore smithsonite while iron occurs as sulphides in iron pyrite and as an oxide in magnetite ore.</p> <p>The most reactive metals, such as sodium, can occur as its chloride in rock salt ore and as nitrate in Chile saltpetre. Therefore, metals can be classified on the basis of their reactivity as metals with low reactivity, metals with moderate reactivity, and metals with high reactivity.</p> <p>a) Name the common name of the nitrate ore of Sodium and write down its chemical formula.</p> <p>b) Name the two different ore of Zinc metal.</p> <p>c) Explain and write down the various steps involved in the extraction of Mercury from its Ore.</p>	4

20

Reactions of metals with water

When a metal reacts with water, a metal hydroxide and hydrogen are formed.

For example:

Sodium reacts vigorously with water.

sodium + water → sodium hydroxide + hydrogen

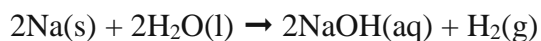

Calcium reacts readily with water.

calcium + water → calcium hydroxide + hydrogen



Calcium hydroxide is slightly *soluble* in water so once the solution is saturated, it starts to become milky as solid calcium hydroxide appear.

The apparatus below is used to react calcium with water and collect the gas. This would not be used with sodium or potassium as they float and the reaction is too vigorous.

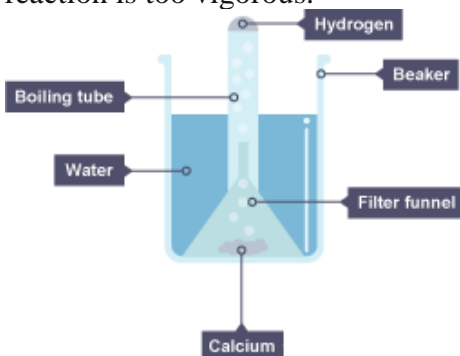

Source -<https://www.bbc.co.uk/bitesize/guides/zfdkf4j/revision/3>

- Analyse and give the particular name given to the formation of Hydrogen gas in the above diagram.
- Explain the reason behind the formation of fire when Na reacts with water.
- Interpret the above diagram and mention the specific term used to describe the continuous evolution of hydrogen gas.

4

	<p>Take three test-tubes. Place clean iron nails in each test-tube.</p> <ul style="list-style-type: none"> • Pour some water in test-tube-1, cork it. • Pour water (boiled/distilled) in test-tube-2, add some oil and cork it. • Put some anhydrous calcium chloride in test-tube-3 and cork it. • After 2-3 days we observe that the nails in test-tube 1 rust because they are exposed to air and water both, while nail in test-tube 2 and 3 do not rust. This shows rusting of iron takes place in the presence of air and moisture 	1.5
12	<p>(a) $2\text{ZnS} + 3\text{O}_2 \rightarrow 2\text{ZnO} + 2\text{SO}_2$</p> <p>$\text{ZnO} + \text{C} \rightarrow \text{Zn} + \text{CO}$</p> <p>(b) The first type of reaction is known as roasting as roasting involves heating of sulphide ores in the presence of excess air. The second type of reaction is called reduction/oxidation/displacement reaction (any of the two reactions involved)</p>	2
13	<p>Alloys melting point and electrical conductivity is lower than pure metals.</p> <p>Stainless steel contains carbon, nickel, chromium and iron.</p>	1 1
SECTION C		
14	<p>(a) Compound X is sodium chloride and its formula is NaCl.</p> <p>(b) Atomic no of sodium is 11 and its electronic configuration is 2,8,1 It means that it is having one valence electron in its outer valence shell is 1.</p> <p>Atomic no of chlorine is 17 and its electronic configuration is 2, 7. Chlorine is having 7 valence electrons.</p> $\begin{array}{l} \text{Na} \rightarrow \text{Na}^+ + e^- \\ 2,8,1 \quad 2,8 \\ \text{(Sodium cation)} \end{array}$ $\begin{array}{l} \text{Cl} + e^- \rightarrow \text{Cl}^- \\ 2,8,7 \quad 2,8,8 \\ \text{(Chloride anion)} \end{array}$ $\text{Na} + \begin{array}{c} \times \times \\ \times \text{Cl} \times \\ \times \times \end{array} \rightarrow (\text{Na}^+) \left[\begin{array}{c} \times \times \\ \times \text{Cl}^- \\ \times \times \end{array} \right]$ <p style="text-align: right;">= NaCl</p>	3
15	<p>(a) Metal A is aluminum and B is Al_2O_3</p> <p>$\text{Fe}_2\text{O}_3 + 2\text{Al} \rightarrow 2\text{Fe} + \text{Al}_2\text{O}_3 + \text{Heat}$</p> <p>(b)</p>	1 2

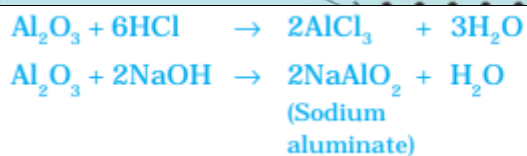

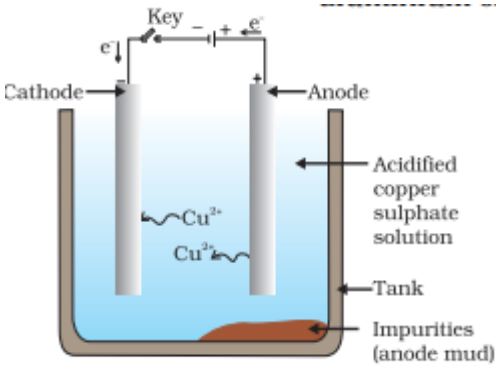
16	<p>(a) An Ionic compound in the solid state do not conduct electricity because movement of ions in the solid is not possible due to their rigid structure. But ionic compounds conduct electricity in the molten state. This is possible in the molten state since the electrostatic forces of attraction between the oppositely charged ions are overcome due to the heat. Thus, the ions move freely and conduct electricity.</p> <p>(b) Ionic compounds are solids and are somewhat hard because of the strong force of attraction between the positive and negative ions. Ionic compounds have high melting point. This is because a considerable amount of energy is required to break the strong inter-ionic attraction.</p>	1 1 1
SECTION D		
17	<p>(a) X – Copper, Y -Copper oxide</p> <p>(b) $2\text{Cu} + \text{O}_2 \rightarrow 2\text{CuO}$</p> <p>$2\text{CuO} + \text{H}_2 \rightarrow 2\text{Cu} + \text{H}_2\text{O}$</p> <div style="text-align: center;">  </div> <p>(c) Electrolytic refining of copper. The electrolyte is a solution of acidified copper sulphate. The anode is impure copper, whereas, the cathode is a strip of pure copper. On passing electric current through the electrolyte, the pure metal from the anode dissolves into the electrolyte. An equivalent amount of pure metal from the electrolyte is deposited on the cathode. The soluble impurities go into the solution, whereas, the insoluble impurities settle down at the bottom of the anode and are known as anode mud.</p>	1 1 1 1 1
18	(a) The compound P is Calcium chloride and its molecular formula is CaCl_2	1+2+2

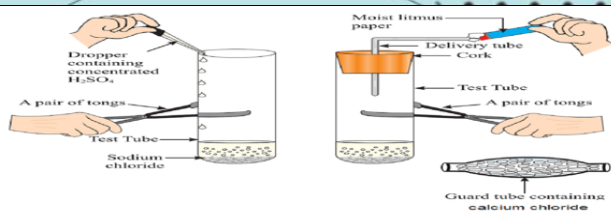

Preparation of HCl gas

SOURCE:

<https://studdy.in/wp-content/uploads/2019/03/activity-2.9-class-10-science-explanation.png>

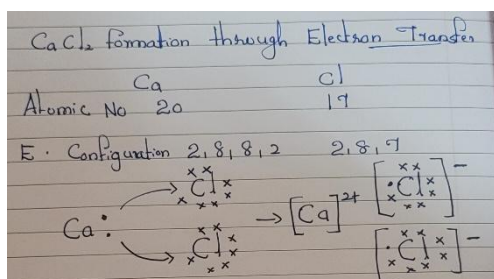

(b)

SECTION E

19	<p>(a) Cinnabar (HgS) is an ore of mercury.</p> <p>(b) Au < Cu < Mg < Na</p> <p>(c) When it is heated in air, it is first converted into mercuric oxide (HgO). Mercuric oxide is then reduced to mercury on further heating.</p> $2\text{HgS(s)} + 3\text{O}_2\text{(g)} \xrightarrow{\text{Heat}} 2\text{HgO(s)} + 2\text{SO}_2\text{(g)}$ $2\text{HgO(s)} \xrightarrow{\text{Heat}} 2\text{Hg(l)} + \text{O}_2\text{(g)}$	1 1 2
20	<p>(a) Hydrogen gas is lighter than water so it gets collected at the top of the inverted test tube.</p> <p>(b) The reaction of Sodium metal with water to produce sodium hydroxide and hydrogen gas is a highly exothermic process and the heat produced is sufficient to start the ignition of hydrogen gas.</p> $2\text{NaOH} + 2\text{H}_2\text{O} \rightarrow 2\text{NaOH} + \text{H}_2$	1 + 2 + 1
	<p>c) $\text{Ca} + 2\text{H}_2\text{O} \rightarrow \text{Ca(OH)}_2 + \text{H}_2$</p>	

CHAPTER- 4**CARBON AND ITS COMPOUNDS**

S NO	QUESTION	MARKS	
	SECTION A		
1	Which of the following is not an allotropic form of carbon? a) diamond b) fullerene c) fluorine d) graphite	1	
2	Identify the unsaturated compounds from the following (i) Propane (ii) Propene (iii) Propyne (iv) Chloropropane (a) (i) and (ii) (b) (ii) and (iv) (c) (iii) and (iv) (d) (ii) and (iii)	1	
3	Choose which of these is not true about homologous series (a) Change in chemical properties (b) Difference in $-CH_2$ and 14u molecular mass (c) Gradation in physical properties (d) Same functional group	1	
4	Mineral acids are stronger acids than organic acids because (i) mineral acids are completely ionised (ii) organic acids are completely ionised (iii) mineral acids are partially ionised (iv) organic acids are partially ionised (a) (i) and (ii) (b) (ii) and (iii) (c) (i) and (iv) (d) (iii) and (iv)	1	
5	In a compound C_3H_7OH if the alcohol group is replaced by a ketone then the formula would be (a) C_2H_5CHO (b) CH_3COCH_3 (c) CH_3CH_2COOH (d) CH_3COOCH_3	1	
6	In the below given reaction, analyse the role of alkaline $KMnO_4$ <div style="text-align: center;"><table border="1" style="display: inline-table;"><tr><td>Alkaline $KMnO_4$</td></tr></table> $CH_3CH_2OH \xrightarrow{\hspace{2cm}} CH_3COOH$</div> (a) reducing agent (b) dehydrating agent (c) catalyst (d) oxidizing agent	Alkaline $KMnO_4$	1
Alkaline $KMnO_4$			
	Question No.7 & 8 consist of two statements – Assertion (A) and Reason (R). Answer these questions selecting the appropriate option given below: a) Both A and R are true, and R is the correct explanation of A. b) Both A and R are true, and R is not the correct explanation of A.		

	c) A is true but R is false. d) A is false but R is true.													
7	Assertion(A) : Carbon compounds can form chain, branched and ring structures. Reason (R) : Carbon exhibits the property of catenation.	1												
8	Assertion(A): n-butane and iso-butane are examples of isomers. Reason (R) : Isomerism is possible only with hydrocarbons having 4 or more carbon atoms.	1												
SECTION B														
9	Soaps are different from detergents. Support this statement with appropriate differences	2												
10	(i) Name the products formed when ethanol burns in air (ii) The reaction between methane and chlorine is considered as a substitution reaction. Justify with a chemical reaction	2												
11	(i) A colourless gas is evolved when ethanoic acid is added to sodium carbonate. Name the gas. Support your answer with a reaction (ii) How would you prove the presence of this gas?	2												
12	Identify the functional groups present in the following compounds (a) $\text{CH}_3\text{COCH}_2\text{CH}_2\text{CH}_2\text{CH}_3$ (b) $\text{CH}_3\text{CH}_2\text{CH}_2\text{COOH}$ (c) $\text{CH}_3\text{CH}_2\text{CH}_2\text{CH}_2\text{CHO}$ (d) $\text{CH}_3\text{CH}_2\text{OH}$	2												
13	Give reasons (i) Why carbon cannot form C^{+4} or C^{-4} compounds. (ii) Graphite is a good conductor of electricity whereas Diamond is a poor conductor	2												
SECTION C														
14	(i) Which element other than carbon exhibits the property of catenation. (ii) Draw the molecular structure of any one element showing catenation property. (iii) Name and draw the structure of an alcohol with five carbon atoms in its molecule.	3												
15	Differentiate between ethanol and ethanoic acid under the following heads: <table border="1" style="margin-left: 20px;"> <thead> <tr> <th>Property</th> <th>Ethanol</th> <th>Ethanoic acid</th> </tr> </thead> <tbody> <tr> <td>Physical state</td> <td></td> <td></td> </tr> <tr> <td>Taste</td> <td></td> <td></td> </tr> <tr> <td>NaHCO_3 Test</td> <td></td> <td></td> </tr> </tbody> </table>	Property	Ethanol	Ethanoic acid	Physical state			Taste			NaHCO_3 Test			3
Property	Ethanol	Ethanoic acid												
Physical state														
Taste														
NaHCO_3 Test														
16	Seema observed that her vessels get blackened by the flame of the burner. she cleaned the burner and then it stops blackening. Why do the vessels get blackened by the flame? Why does coal burn without flame? Which will have black residue on burning ethane or ethene? justify your answer.	3												
SECTION D														

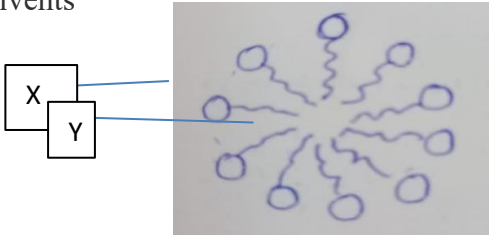
17	<p>Rani while doing particular reactions detected that heating of substance 'P' with vinegar like smell with a substance 'Q' (used as an industrial solvent) in presence of conc. Sulphuric acid on a water bath gives a sweet-smelling liquid 'R' having molecular formula $C_4H_8O_2$. When heated with caustic soda (NaOH), 'R' gives back the sodium salt of and the compound 'Q'. Identify 'P', 'Q', and 'R'. Describe the changes with the help of suitable chemical equations.</p>	5
18	<p>When Hydrogen is added to a compound 'X' in the presence of particular catalysts it gives 'Y' which enhances the taste of a dish but it is harmful to use in our daily diet as it causes our cholesterol level to increase.</p> <p>(i) Identify 'X' and 'Y'</p> <p>(ii) Name the reaction and write a balanced chemical reaction.</p> <p>(iii) Identify the catalyst</p> <p>(iv) Why is the usage of 'Y' harmful and how can you avoid it?</p>	5
SECTION E		
19	<p>The primary reason behind the formation of the toxic foam is high phosphate content in the wastewater because of detergents used in dyeing industries, dhobi ghat and households. Yamuna's pollution level is so bad that parts of it have been labelled 'dead' as there is no oxygen in it for aquatic life to survive.</p>  <p>Predict the pH value of the water of river Yamuna if the reason for froth is high content of detergents dissolved in it.</p> <p>If a sample of water containing detergents is provided to you, which of the following methods will you adopt to neutralize it?</p> <p>Give two after effects of high content of phosphate ion in river Yamuna.</p>	4
20	<p>Most dirt is oily in nature and as you know, oil does not dissolve in water. The molecules of soap are sodium or potassium salts of long-chain carboxylic acids. The ionic-end of soap interacts with water while the carbon chain interacts with oil. The soap molecules, thus form structures called micelles, where one end of the molecules is towards the oil droplet while the ionic-end faces outside. This forms an emulsion in water. The soap micelle thus helps in pulling out the dirt in water and we can wash our clothes clean.</p> <p>(i) What is scum? How can you overcome this?</p> <p>(ii) What type of a solution can soap molecules form?</p> <p>(iii) Identify 'X' and 'Y' and their solvents</p> 	4

CH 4 Marking scheme CARBON AND ITS COMPOUNDS

Q NO	SOLUTION	MARKS								
1	c	1M								
2	d	1M								
3	a	1M								
4	c	1M								
5	b	1M								
6	d	1M								
7	a	1M								
8	b	1M								
9	<table border="1"> <thead> <tr> <th>Soaps</th> <th>Detergents</th> </tr> </thead> <tbody> <tr> <td>(i) These are sodium or potassium salts of long chain fatty acids.</td> <td>(i) These are ammonium and sulphonate salts of long chain fatty acids.</td> </tr> <tr> <td>(ii) Soaps are biodegradable</td> <td>ii) Detergents are non biodegradable</td> </tr> <tr> <td>iii) Their efficiency decreases in hard water</td> <td>iii) Their efficiency is unaffected in hard water</td> </tr> </tbody> </table>	Soaps	Detergents	(i) These are sodium or potassium salts of long chain fatty acids.	(i) These are ammonium and sulphonate salts of long chain fatty acids.	(ii) Soaps are biodegradable	ii) Detergents are non biodegradable	iii) Their efficiency decreases in hard water	iii) Their efficiency is unaffected in hard water	2M
Soaps	Detergents									
(i) These are sodium or potassium salts of long chain fatty acids.	(i) These are ammonium and sulphonate salts of long chain fatty acids.									
(ii) Soaps are biodegradable	ii) Detergents are non biodegradable									
iii) Their efficiency decreases in hard water	iii) Their efficiency is unaffected in hard water									
10	(i) CO ₂ and H ₂ O are formed. (ii) It is because Chlorine atom substitutes Hydrogen atom of methane to form Chloro methane and hydrogen chloride. $\text{CH}_4 + \text{Cl}_2 \xrightarrow{\text{light}} \text{CH}_3\text{Cl} + \text{HCl}$ (in the presence of light)	1M 1M								
11	(i) CO ₂ $2\text{CH}_3\text{COOH} + \text{Na}_2\text{CO}_3 \xrightarrow{\quad} 2\text{CH}_3\text{COONa} + \text{H}_2\text{O} + \text{CO}_2$ (ii) When the gas is passed through lime water, it turns milky.	½ M 1 M ½ M								

	(b) Because flame is only produced when gaseous substance burn.	1M
	(c) Ethene will give black residue because it is unsaturated hydrocarbon.	1M
	SECTION D	
17	P - Ethanoic acid/ acetic acid/ CH ₃ COOH	1M
	Q - Ethanol/ Ethyl alcohol/ C ₂ H ₅ OH	1M
	R - Ethyl ethanoate/ Ester – CH ₃ COCH ₂ CH ₃	1M
	$\text{CH}_3\text{COOH} + \text{CH}_3\text{CH}_2\text{OH} \xrightarrow{\text{acid}} \text{CH}_3\text{COCH}_2\text{CH}_3$	1M
	$\text{CH}_3\text{COOC}_2\text{H}_5 \xrightarrow{\text{NaOH}} \text{C}_2\text{H}_5\text{OH} + \text{CH}_3\text{COONa}$	1M
18	(i) X – Unsaturated hydrocarbon (Vegetable oils) Y – Saturated hydrocarbon (Animal fats)	½ X 2 = 1M
	(ii) Addition reaction (balanced chemical reaction)	2M
	(iii) Nickel or palladium	1M
	(iv) Using ‘Y’ is harmful as it is a saturated hydrocarbon. Results in formation of cholesterol	1M
	We can avoid by using vegetable oils which are un saturated hydrocarbons.	1M
	SECTION E	
19	(a) More than 10 (basic).	1M
	(b) Treating it with vinegar or any other acidic solution.	1M
	(c) Decrease in levels of dissolved oxygen, increase in algae.	1 X 2 = 2M
20	(i) While using a soap with hard water an insoluble substance (white precipitate) remains after washing with water which is called a scum. Can overcome by using detergents	1 X 2 = 2M
	(ii) Soap molecules form a colloidal solution.	1M
	(iii) X- Hydrophilic end – soluble in water Y – Hydrophobic end – soluble in hydrocarbons	1M

CHAPTER - 5 : LIFE PROCESSES

Q NO	SECTION A	MARKS
1	<p>The process used to clean the blood of a person by separating nitrogenous waste through a machine.</p> <p>a. osmosis b. filtration c. dialysis d. double circulation</p>	1
2	<p>If we remove the enzyme salivary amylase from the saliva, which of the following process will be affected.</p> <p>a. breakdown of protein into amino acids. b. breakdown of fats into fatty acids and glycerol c. breakdown of starch into sugars d. breakdown of haemoglobin.</p>	1
3	<p>During the process of photosynthesis carbon dioxide undergoes which process to form carbohydrate.</p> <p>a. oxidation b. reduction c. combustion d. precipitation</p>	1
4	<div style="text-align: center;">  </div> <p>Identify the different parts-</p> <p>a. 1) epidermal cell 2) guard cells 3) chloroplast 4) stomatal pore b. 1) guard cells 2) epidermal cell 3) chloroplast 4) stomatal pore c. 1) stomatal pore 2) epidermal cell 3) chloroplast 4) guard cells d. 1) chloroplast 2) guard cell 3) stomatal pore 4) epidermal cell</p>	1
5	<p>The carbs are stored in humans in the form of -</p>	1

	<p>a. starch</p> <p>b. glycogen</p> <p>c. lipids</p> <p>d. glycerol</p>	
6	<p>Maximum affinity of haemoglobin is with</p> <p>a. Oxygen</p> <p>b. Carbon dioxide</p> <p>c. Carbon monoxide</p> <p>d. Ammonia</p>	1
7	<p>Assertion: Blood is the respiratory fluid of the body.</p> <p>Reason: Blood carries nutrients and waste in the body.</p>	1
8	<p>Assertion: Desert plants break-down the process of photosynthesis into two parts.</p> <p>Reason: High temperatures and limited availability of water in deserts.</p>	1
SECTION B		
9	Explain two major glycolytic pathways in a cell.	2
10	Describe the function of enzymes present in pancreatic juice on the food being digested.	2
11	Illustrate the structure of villi and how its structure aids in its efficiency of absorption.	2
12	Draw a comparison between the components of blood and lymph.	2
13	Identify the excretory products of plants.	2
SECTION C		
14	Justify the process of photosynthesis being broken down into day and night cycle in desert plants.	3
15	Outline the processes that cause the transport of water in xylem and the transport of food in phloem, with the aim to bring out the difference between the 2 modes of transport.	3
16	<p>Categorize the following organisms on the basis of the number of chambers in their heart- Two-chambered, Three-chambered, Four-chambered.</p> <p><u>Organisms</u> - Frog, Dolphin, Clownfish, Seahorse, Penguin, Salamander</p>	3

	SECTION D	
17	Device an experiment to show the role of xylem in the transport of water in plants.	5
18	Give an argument to support the presence of septum to separate the oxygenated and deoxygenated blood in aves and mammals.	5
	SECTION E	
19	<p>The kidney participates in whole-body homeostasis, regulating acid–base balance, electrolyte concentrations, extracellular fluid volume, and blood pressure. The kidney accomplishes these homeostatic functions both independently and in concert with other organs, particularly those of the endocrine system.</p> <p>a. What is the excretory product that is filtered out of the body through urine by kidneys in mammals?</p> <p>b. What is the amount of filtrate excreted from the body in a day.</p> <p>c. Name the blood vessel that brings the blood to the kidney for purification and list the components present in the blood being carried out by this blood vessel.</p>	4
20	<p>The respiratory system is a biological system consisting of specific organs and structures used for gas exchange in animals and plants. The anatomy and physiology that make this happen varies greatly, depending on the size of the organism, the environment in which it lives and its evolutionary history.</p> <p>a. What is the importance of the presence of residual volume in lungs?</p> <p>b. What is the role of cilia along the nasal passage?</p> <p>c. Write the reason for the requirement of a respiratory pigment in large animals and name the pigment.</p>	4

ANSWER KEY**CHAPTER: LIFE PROCESSES**



A O	Q NO	SECTION A	MARKS
	1	c	1
	2	c	1
	3	b	1
	4	b	1
	5	b	1
	6	c	1
	7	b	1
	8	a	1
		SECTION B	
	9	The aerobic pathway and anaerobic pathway process can be explained	2
	10	Function of trypsin is digesting proteins and lipase is breaking down emulsified fats.	2
	11	Relevant diagram of villi to be drawn. The folding that causes finger like projections increases the surface area for absorption cold and water.	2
	12	Any two differences can be given.	2
	13	water, oxygen, resins and gums and deposits in dead cells.	2
		SECTION C	
	14	High amount of sun light and heat leads to major water loss during day time through stomata hence they open the stomata at night to take in carbon dioxide and form an intermediate, which is converted into the final product in the presence of sunlight during day time.	3
	15	Xylem : transpiration, pressure gradient which are physical processes. Phloem : use of ATP for translocation active as well as passive by diffusion	3

16	Two-chambered: clownfish, seahorse Three-chambered: salamander, frog Four-chambered: dolphin, penguin	3
SECTION D		
17	STEPS: (or any other relevant experiment) a) The shoot of Balsam plant which is leafy is placed in an Eosin solution. b) After some time, it is observed that the vein of leaves become red and shoot has red streaks. c) Transverse section is cut and stained and found that it is xylem tissues. This shows that the water is translocated in xylem tracheid's and vessels. Rest of the tissues remain unstained Any relevant experiment showing the movement of water in xylem.	5
18	a) High energy demand in case of aves and mammals as they have to maintain a constant body temperature. b) explanation for the process of double circulation.	2.5 2.5
SECTION E		
19	a) Urea b) 1-2 L c) renal artery; oxygen, protein, salts, glucose, etc. Any (4) relevant substances can be mentioned.	1+1+2
20	a) so that sufficient amount of time for oxygen to be absorbed and carbon dioxide to be released. b) Trap dust, other harmful particles. c) the diffusion pressure alone cannot take care of oxygen delivery to all parts of the body; Haemoglobin.	1+1+2

CHAPTER- 6: CONTROL AND COORDINATION

Q NO	SECTION A	MARKS
1	<p>Which statement is false with respect to thyroxine?</p> <p>(a) Iron is essential for the synthesis of thyroxine</p> <p>(b) It regulates carbohydrates, protein and fat metabolism in the body.</p> <p>(c) Thyroid gland requires iodine to synthesise thyroxine</p> <p>(d) Thyroxin is also called thyroid hormone.</p>	1
2	<p>Gland associated gland with fear, fight or flight response is.</p> <p>a) Pancreas</p> <p>b) Pituitary</p> <p>c) Adrenal</p> <p>d) Thyroid</p>	1
3	<div style="text-align: center;"> <pre> graph LR Stimulus --> Receptor Receptor -- "Sensory neurons" --> A A --> Effector Effector -- "Response" --> Response Effector -- "B" --> A </pre> </div> <p>Name the missing terms- A and B</p> <p>(a) Spinal cord and motor neuron</p> <p>(b) Brain and sensory neuron</p> <p>(c) Cranial nerves and motor neuron</p> <p>(d) Brain and relay neuron</p>	1
4	<p>Neuromuscular junction is a bridge between:</p> <p>(a) Axon of one neuron with cyton of another neuron</p> <p>(b) Muscle fibre of one neuron with dendron of another neuron</p> <p>(c) Muscle fibre of one neuron with nerve endings of another neuron</p> <p>(d) Axon of one neuron with nerve endings of another neuron</p>	1
5	<p>Which plant hormone promotes senescence?</p> <p>(a) Auxin</p> <p>(b) Gibberellin</p>	1

	(c) Cytokinin (d) Abscisic acid	
6	<p>Which of the following statements are true about the human brain?</p> <p>(i) The main thinking part of the human brain is the hindbrain. (ii) Centres of hearing, smell, memory, sight etc. are located in fore brain. (iii) Involuntary actions like salivation, vomiting, blood pressure is controlled by the medulla in the hindbrain. (iv) Cerebellum does not control posture and balance of the body</p> <p>(a) (i) and (ii) (b) (i), (ii) and (iii) (c) (ii) and (iii) (d) (iii) and (iv)</p>	1
7	<p>Assertion (A): The effect of Auxin hormone on the growth of root is exactly opposite to that on a stem.</p> <p>Reason(R): Auxin hormone increases the rate of growth in the root and decrease rate of growth in the stem.</p>	1
8	<p>Assertion (A): A receptor is a specialized group of cells in the same organ that perceive a particular type of stimulus.</p> <p>Reason (R): Different sense organs have different receptors for detecting stimuli.</p>	1
SECTION B		

9	 <p>https://images.app.goo.gl/hWMkjgUvv6ygXVyp9</p> <p>Relate the given picture with the type of movement in the plant. Also, name the phytohormone associated with it.</p>	2
10	<p>Compare the terms voluntary and involuntary actions. Classify these actions: blinking of eyes, movement of diaphragm, running, nodding of head.</p>	2
11	<p>Enlist the reason that leads to dramatic changes at puberty . Can you name the glands along with the messengers released by them?</p>	2
12	 <p>https://images.app.goo.gl/MkjgUXYhygXVyp9</p> <p>(a) Integrate the labeling A and B to the human nervous system. (b) How are these tissues/organs protected?</p>	2
13	<p>What is chemotropism? Give one example.</p>	2
SECTION C		
14	<p>Annika’s mother has been advised by a doctor to reduce her carbohydrates intake.</p> <p>(a) Name the disease she is suffering from and due to which hormone deficiency? (b) Identify the gland that secretes it and mention the function of this hormone.</p> <p>Discuss how the time and amount of secretion of any hormone is coordinated in our body?</p>	3
15	<p>The following items are arranged by the teacher in the class: Two transparent plastic covers with mud, two saplings, nutrient solution.</p>	3

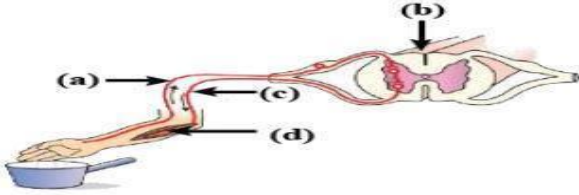
	Design an activity to demonstrate geotropism.	
16	 <p>(NCERT)</p> <p>Co-relate the labeling (a), (b), (c) and (d) so that the diagram gives a meaningful concept. Connect the two words related with the above diagram.</p>	3
SECTION D		
17	<p>(a) What does a Mimosa pudica plant do in response to touch? What is the phenomenon known as?</p> <p>(b) How do pea plants climb up other plants? Explain.</p> <p>(c) Wilting of leaves happens due to which hormone?</p>	5
18	<p>(a) The human brain is divided into how many regions. Name these three regions.</p> <p>(b) Which part of the brain controls activities like salivation.</p> <p>(c) In a neuron, how is an electrical impulse created and what is the role of synapse in this context?</p>	5
SECTION E		
19	<p>Read the text and answer the questions that follow:</p> <p>Hormones are chemical substances secreted in very small amounts by specialized tissues in the body called endocrine glands. These hormones coordinate the activities of living organisms and also their growth. Hormones are made inside the body of an organism in very small amounts. They are secreted in small amounts by the endocrine glands and are poured directly into the blood and carried throughout the body by blood circulatory system. The hormones have their effect at the sites different from the sites where they are made. They act on specific tissues or organs.</p> <p>(a) The hormones act on specific organs which are called as?</p> <p>(b) What are Chemical messengers called as?</p> <p>(c) Justify the statement “The hormones coordinate the activities of the body”.</p>	4
20	<p>Read the text and answer the questions that follow:</p> <p>To carry out a simple function such as eating food there has to be coordination of the eyes, hands and the mouth. The eyes have to focus on the food, the hands have to pick it up and take it to the mouth where it will be chewed. All these actions have to be coordinated in such a manner that they follow a particular sequence and the action is completed. A similar mechanism is also needed for internal functions of the body. This function is carried out by the nervous system. It is composed of:</p>	4

(a) Specialized cells which can detect, receive and transmit different kinds of stimuli. These are called neurons.

(b) Nerve fibres which are certain bundles of extended processes of nerve cells.

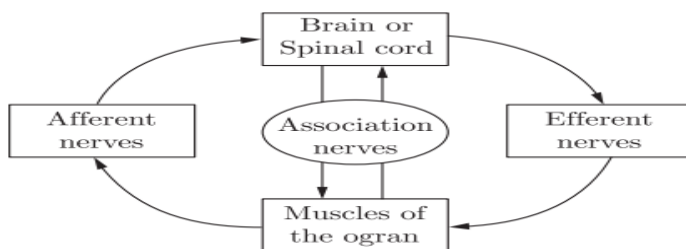

(a) What will be the correct sequence in which conduction of information through nerves takes place?

(b) What is the role of the central nervous system?

(c) What happens when the dendritic tip of a nerve cell receives a signal?

ANSWER KEY CHAPTER- 6 CONTROL AND COORDINATION

Q NO	SECTION A	MAR KS
1	(a)	1
2	(c)	1
3	(a)	1
4	(c)	1
5	(d)	1
6	(c)	1
7	(d)	1
8	(b)	1
	SECTION B	
9	Stem movement towards light/ phototropism, auxin	1+1
10	Any one point of difference, voluntary- running, nodding of head, involuntary - blinking of eyes, movement of diaphragm,	$\frac{1}{2} + \frac{1}{2}$ $+ \frac{1}{2} + \frac{1}{2}$
11	Due to sex glands/reproductive glands starts functioning. Testes – testosterone, ovary- estrogen (any one combination)	1+1
12	(a) A is brain and B is spinal cord which are components of CNS (b) Brain inside the skull, spinal cord in vertebral column, 3 layers of meninges and the cerebrospinal fluid.	1+1
13	Chemotropism is the movement of a part of the plant in response to a chemical stimulus. It can be positive chemotropism or negative chemotropism. Example: The growth of pollen tube on the stigma towards a chemical which is produced by an ovule leading to the process of fertilisation in a flower.	2
	SECTION C	
14	(a) Diabetes, Insulin (b) Pancreas, regulation of blood sugar level	1+1+1

	Hormones are released in the blood stream which are under control of our master gland and then under control of feedback mechanism.	
15	Sequential steps in which growing a sapling in two different plastic bags for one – two weeks by keeping one bag in vertical and other in horizontal directions. At last comparing the growth of roots in two different directions. Roots are positively geotropic and the shoots are negatively geotropic	3
16	(a) Sensory neuron/nerve. (b) Relay neuron / interneuron. (c) Effector (d) Receptor These all four involves in the conduction of neural message from the receptor to the effector. Reflex actions and reflex arc are the two terms.	2+1
SECTION D		
17	(a) Touch – me – not plant folds its leaflets on touching. This type of movement is called Growth independent movement (nastic movement) (b) Pea plants have special parts called as tendrils which are sensitive to touch as these are growth related movements. (c) Abscisic acid/ ABA	2+2+1
18	(a) Three, Fore brain, mid brain and hind brain (b) Medulla (c) A synapse is the gap between the two neurons. Here the axon terminal of one neuron is in close proximity to the dendrite of the second neuron. When a nerve impulse reaches the knob like nerve ending of an axon, a tiny amount of a chemical substance is released in the synapse that triggers electric potential in the dendrons of the next neuron.	2+1+2
SECTION E		
19	(a) Target organs / target site (b) Hormones (c) At synapse the electrical signals converted into chemicals, that can easily cross over the gap and pass on to the next neurons where it again converted into electrical signals.	1+1+2
20	(a) Dendrite → cell body → axon → nerve ending → synapse → dendrite. (b) The central nervous system is the body's processing centre. The brain controls most of the functions of the body. (c) Dendrites receive the data or signals from another neuron. Dendrites which collects and stores all incoming information from axon terminals, which conducts electrical impulses towards the cell body of the nerve cell.	1+1+2

CHAPTER- 7 HOW DO ORGANISMS REPRODUCE?

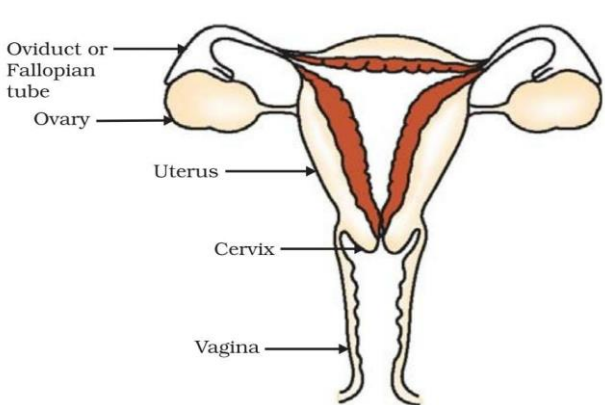
Q NO	SECTION A	MARKS
1	<p>Which of the following diseases is caused by a sexually-transmissible bacterium?</p> <p>a) HIV-AIDS b) Warts c) Syphilis d) Cholera</p>	1
2	<p>During reproduction, characters are transmitted from parents to offspring indicates:</p> <p>a) Only variations with parents b) Only similarities with parents c) Both similarities and variations with parents d) None of these</p>	1
3	<p>Out of the following choose the correct sequence of reproductive stages seen in flowering plants:</p> <p>a) Zygote, gametes, embryo, seedling b) Seedling, embryo, zygote, gametes c) Gametes, embryo, zygote, seedling d) Gametes, zygote, embryo, seedling</p>	1
4	<p>What is the number of male gametes present in each pollen grain?</p> <p>a) 1 b) 2 c) 3 d) 4</p>	1
5	<p>Fertilisation is the union of a sperm with a mature egg.</p> <div style="text-align: center;">  </div> <p>(Source: Class X NCERT, Page no.137)</p>	1

	<p>In which part of the female reproductive system does fertilization takes place?</p> <p>a) Oviduct b) Ovary c) Uterus d) Vagina</p>	
6	<p>Which of the following contraceptive methods can be used to avoid pregnancy?</p> <p>a) Barrier method b) Chemical method c) Surgical method d) All of these</p>	1
	<p>Following questions consist of two statements – Assertion (A) and Reason (R). Answer these questions selecting the appropriate option given below:</p> <p>(a) Both A and R are true and R is the correct explanation of A. (b) Both A and R are true but R is not the correct explanation of A. (c) A is true but R is false. (d) A is false but R is true.</p>	
7	<p>Assertion(A): Organisms resulting from sexual reproduction generally exhibit a higher chance of survival compared to those produced through asexual reproduction.</p> <p>Reason(R): Variations provide advantage to individuals for their survival.</p>	1
8	<p>Assertion(A): Menstrual cycles in human females may cease around the age of 50.</p> <p>Reason(R): An irregular reproductive phase is often signalled by changes in the menstrual cycle.</p>	1
SECTION B		
9	<p>Mansi bought some pineapples and she liked the taste of pineapple. So, she decided to grow her own pineapples that will have the same taste.</p> <p>a) What cultivation method would be most suitable for Mansi to choose? Give one example for the same from your surroundings. b) Why would Mansi adopt this method?</p>	2
10	<p>A and B are two organisms both reproduce by budding. Organism A lives in freshwater. If the individual organism is somehow cut or broken up into many pieces, many of these pieces grow into separate individuals. Organism B is used in making alcohol from sugar.</p>	2

	<p>a) What are organisms A and B.</p> <p>b) What is the name of the process in which B converts sugar into alcohol. Give one example from your daily life for this process.</p>	
11	Embryo gets the nourishment inside the mother's body. Justify.	2
12	What functions do the seminal vesicles and prostate gland serve in the reproductive system?	2
13	Compare and derive the similarities between fragmentation and fission in organisms	2
SECTION C		
14	<p>The reproductive parts of angiosperms are located in the flower. X is the male reproductive part and it produces A that are yellowish in colour. Y is the female reproductive part.</p> <p>a) Name X and Y.</p> <p>b) What are particles A? If the plant has $2n$ number of chromosomes, how many can be expected in A?</p> <p>c) What is the process of transferring A from one flower to another of similar plant known as?</p>	3
15	Boys develop moustache at puberty. List any three changes seen among boys at puberty and compare with that of girls at puberty.	3
16	<p>a) Draw and locate the part in the female reproductive system where Copper-T is inserted.</p> <p>b) Which part is blocked in female reproductive system to prevent fertilization? Name the procedure involved.</p>	2+1
SECTION D		
17	<p>A female of 49 years of age is undergoing some hormonal changes due to which she is facing some mental and physical issues.</p> <p>a) What can be the possible reason for this? Explain.</p> <p>b) What marks the beginning of reproductive age in females? Which hormone is responsible for attaining this?</p> <p>c) Explain menstrual cycle in females.</p>	2+1+2
18	<p>a) How does the use of condoms contribute to the well-being of both individuals engaged in sexual activity?</p> <p>b) Evaluate the positive and negative aspects of using oral contraceptives.</p> <p>c) What is female foeticide? What impact does it have on the overall health of a society?</p>	2+2+1
SECTION E		

19	<p>Four microorganisms, named as P, Q, R and S exhibit the characteristics as mentioned below:</p> <p>The organism P is a microscopic single-celled animal which causes malaria disease in human beings. The organism Q is a parasitic protozoan which causes a disease known as kala-azar. The organism R is also a unicellular animal which is slipper-shaped having a large number of tiny hairs all around its body. The organism S is a unicellular animal which has no fixed shape, it can change its body shape according to its need.</p> <p>a) Name the organisms P, Q, R and S. b) What name is given to the asexual method of reproduction of organism P and organism Q respectively. c) Name one characteristic body feature of organism Q. d) Name the insect which carries organism P and transmits it from one person to another.</p>	4
20	<p>HIV attacks the body's white cells. HIV targets and infiltrates CD4 cells, a type of T cell. It destroys the cells and reduces the body's ability to combat other infectious diseases.</p> <p>a) Name the disease caused by HIV? Write the full form of HIV. b) How is this disease caused and its mode of spread? c) How the transmission of this disease can be prevented? Mention any two points.</p>	1+1+2

ANSWER KEY

CHAPTER- 7 HOW DO ORGANISMS REPRODUCE?

Q NO	SECTION A	MARKS
1	c) Syphilis	1
2	c) Both similarities and variations with parents	1
3	d) Gametes, zygote, embryo, seedling	1
4	b) 2	1
5	a) Oviduct	1
6	d) All of these	1
7	a) Both A and R are true and R is the correct explanation of A	1
8	c) A is true but R is false.	1
SECTION B		
9	a) Vegetative propagation/Asexual Reproduction	1

	<p>Example: Strawberries or any other correct response</p> <p>b) This is because the fruit produced through vegetative propagation would carry conserved parental characteristics. or any other logically correct answer.</p>	1						
10	<p>a) A-Hydra/ Planaria</p> <p>B-Yeast</p> <p>b) Fermentation</p> <p>Example: Fermentation of grapes by yeast results in the production of wine.</p>	1 1						
11	<p>The lining of the uterus thickens after fertilization. The blood flow is good so as to nourish the growing embryo. Placenta is a special tissue which is embedded in the uterine wall and helps the embryo get the nourishment from the mother's tissue. Placenta has villi on the embryo side and blood space on the mother's side. This spacing provides a large area between the mother and the embryo and also helps for waste removal.</p>	2						
12	<p>Lubrication of sperms and providing of a fluid medium for the easy transportation of sperms takes place with the help of secretions from the seminal vesicles and the prostate gland. These secretions also provide nutrients in the form of fructose, calcium and some enzymes.</p>	2						
13	<table border="1" style="width: 100%; border-collapse: collapse;"> <thead> <tr> <th style="text-align: center;">Fragmentation</th> <th style="text-align: center;">Fission</th> </tr> </thead> <tbody> <tr> <td>An organism breaks into fragments, and each fragment can potentially grow into a new individual.</td> <td>Fission involves the division of a parent organism into two or more individuals, each capable of independent existence.</td> </tr> <tr> <td>Each fragment has the potential to develop into a genetically identical organism.</td> <td>The division typically results in genetically identical daughter cells.</td> </tr> </tbody> </table>	Fragmentation	Fission	An organism breaks into fragments, and each fragment can potentially grow into a new individual.	Fission involves the division of a parent organism into two or more individuals, each capable of independent existence.	Each fragment has the potential to develop into a genetically identical organism.	The division typically results in genetically identical daughter cells.	2
Fragmentation	Fission							
An organism breaks into fragments, and each fragment can potentially grow into a new individual.	Fission involves the division of a parent organism into two or more individuals, each capable of independent existence.							
Each fragment has the potential to develop into a genetically identical organism.	The division typically results in genetically identical daughter cells.							
SECTION C								
14	<p>a) X-Stamen</p> <p>Y-Pistil</p> <p>b) Pollen grain</p> <p>c) Cross pollination</p>	1 1 1						
15	Boys at Puberty: (any 3 sets of changes)							

- 3
1. **Facial Hair Growth:** Along with the development of a moustache, boys experience the growth of facial hair, including beard and sideburns.
 2. **Voice Deepening:** The larynx (voice box) undergoes changes, resulting in a deeper and more mature voice.
 3. **Growth Spurt:** Boys experience a significant increase in height and weight during puberty, known as a growth spurt.
 4. **Muscle Development:** Testosterone, the primary male sex hormone, contributes to the development of muscle mass and strength.
 5. **Adam's Apple:** The Adam's apple becomes more prominent due to the growth of the larynx.
 6. **Increased Sweating:** Sweat and sebaceous glands become more active, leading to increased sweating and oil production.
 7. **Genital Development:** The testes and penis undergo growth and maturation.
 8. **Enlargement of Adam's Apple:** The thyroid cartilage in the larynx enlarges, leading to the prominence of the Adam's apple.

Girls at Puberty:

1. **Breast Development:** The breasts start to develop, and there is an increase in size and shape.
2. **Menstruation:** Menstrual cycles begin, marking the onset of the ability to conceive.
3. **Hip Widening:** The hips widen as part of the overall body shape changes, contributing to a more feminine appearance.
4. **Growth Spurt:** Girls also experience a growth spurt, although it generally occurs earlier than in boys.
5. **Body Fat Redistribution:** Fat distribution shifts towards the hips and thighs, contributing to a more curvaceous figure.
6. **Hair Growth:** While girls already have some fine body hair, there may be an increase in the growth of terminal hair, especially in the pubic and underarm regions.
7. **Skin Changes:** Girls may experience changes in skin texture and increased oiliness.
8. **Genital Development:** The ovaries and uterus undergo development, preparing the body for potential pregnancy.
9. **Hormonal Changes:** Estrogen and progesterone, the primary female sex hormones, regulate the menstrual cycle and

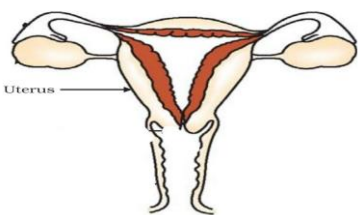
	contribute to the development of secondary sexual characteristics.	
16	<p>a) The Copper-T is inserted into the uterus.</p>  <p>(Source: Class X NCERT, Page no.137)</p> <p>b) By blocking the fallopian tubes. Tubectomy prevents the sperm from reaching the egg and fertilizing it.</p>	2+1
SECTION D		
17	<p>a) Menopause</p> <p>Menopause is a natural biological process that marks the end of a woman's reproductive years. It typically occurs in the late 40s or early 50s, which causes hormonal imbalance. Menopause is defined as the absence of menstrual periods for 12 consecutive months.</p> <p>b) Menarche/Menstruation/Menstrual cycle</p> <p>Hormone: Estrogen</p> <p>c) Menstruation is the normal bleeding of the vaginal line, which starts at puberty and lasts till menopause. During this period, the body prepares itself for pregnancy.</p> <p>Every month an egg is released from one of the ovaries at the same time when the uterus prepares itself for the fertilized egg. The inner lining of the uterus gets thickened and is supplied with a sufficient amount of blood for the embryo. Since there is no interaction between the egg and the sperms, the fertilization of the egg doesn't take place. So, when the egg doesn't get fertilized, the uterus lining breaks down slowly resulting in menstruation.</p>	2+1+2
18	<p>a) The use of condoms contributes to the wellbeing of both individuals engaged in sexual activity:</p> <ul style="list-style-type: none"> ▪ Condoms act as a barrier method, preventing unwanted pregnancies. ▪ Condoms help protect against a wide range of sexually transmitted infections. <p>b) Positive Aspects of Using Oral Contraceptives:</p>	2+2+1

	<ul style="list-style-type: none"> ▪ Prevent unwanted pregnancies <p>Negative Aspects of Using Oral Contraceptives:</p> <ul style="list-style-type: none"> ▪ Side Effects ▪ Increased Risk of Blood Clots ▪ No Protection Against STIs ▪ Not Suitable for Everyone <p>c) Female foeticide refers to the deliberate act of selectively aborting female foetuses</p> <p>Impact on the Society:</p> <ul style="list-style-type: none"> ▪ Gender Imbalance ▪ Social Disruption or any other logically correct answer 	
SECTION E		
19	<p>a) P-Plasmodium, Q-Leishmania, R-Paramecium, S-Amoeba</p> <p>b) P-Multiple fission</p> <p>Q-Binary fission</p> <p>c) Organism Q (Leishmania) has a whip-like structure called flagellum at its one end.</p> <p>d) Female Anopheles mosquito</p>	4
20	<p>a) AIDS</p> <p>HIV stands for Human Immunodeficiency Virus.</p> <p>b) AIDS (Acquired Immunodeficiency Syndrome) is caused by a virus (HIV).</p> <ul style="list-style-type: none"> ▪ Modes of HIV Transmission: ▪ Unprotected Sexual Contact ▪ Contaminated Blood ▪ Mother-to-Child Transmission ▪ Contaminated Instruments ▪ From Mother to Child During Pregnancy (any 2 points) <p>c) The transmission of AIDS can be prevented by:</p> <ul style="list-style-type: none"> ▪ The correct use of condoms during sexual intercourse is an effective way to prevent the transmission of HIV. ▪ Individuals who use drugs intravenously should avoid sharing needles, syringes, or other injection equipment. (any other relevant answer) 	1+1+2

CHAPTER- 8 HEREDITY

Q NO	SECTION A	MARKS
1	<p>A man with blood group A marries a woman having blood group O. What will be the blood group of the child?</p> <p>(a) O only</p> <p>(b) A only</p> <p>(c) AB</p> <p>(d) Equal chance of acquiring blood group A or blood group O.</p>	1
2	<p>A zygote which has an X chromosome inherited from the father will develop into a</p> <p>(a) girl</p> <p>(b) boy</p> <p>(c) either boy or girl</p> <p>(d) X chromosome does not influence the sex of a child</p>	1
3	<p>When a Mendel crossed tall plants (TT) with dwarf plants (tt), he obtained a combination of traits in F₂ generation in the ratio of 1:2:1. Which of the following represents the given ratio?</p> <p>(a) TT: tt: Tt</p> <p>(b) Tt: TT: tt</p> <p>(c) TT: Tt: Tt</p> <p>(d) TT: Tt: tt</p>	1
4	<p>Dinesh draws a monohybrid cross between tall pea plant (Tt) and dwarf pea plant (tt) as shown.</p> <div style="text-align: center; margin: 10px 0;"> </div> <p>What will be the phenotypic ratio?</p> <p>(a) 1 : 1</p>	1

	(b) 3 : 1 (c) 1 : 2 (d) 1 : 3	
5	The brown eyed father and black-eyed mother has all brown eyed children. What could be the genetic makeup of both the parents? (Take B for brown and b for black trait). (a) Bb X Bb (b) BB X Bb (c) BB X bb (d) Bb X bb	1
6	Exchange of genetic material takes place in: (a) Vegetative reproduction (b) Asexual reproduction (c) Sexual reproduction (d) Budding	1
7	Assertion(A): The sex of a child is determined by the mother. Reason (R): Humans have two types of sex chromosomes: XX and XY.	1
8	Assertion: Monohybrid cross deals with inheritance of one pair of contrasting characters. Reason: Dihybrid cross deals with inheritance of two pairs of contrasting characters.	1
	SECTION B	
9	When we observe a field of sugarcane we will find very little variation among the individual plants but when we observe human beings quite distinct variations are found. Give reasons in the light of scientific reasons behind it.	2
10	In an asexually producing organism, a trait 'A' exists in 10% of a population and trait 'B' exists in 75% of the same population. Which of the two traits is likely to arisen earlier? Give reason to justify your choice.	2
11	Sexually reproducing parents and their offspring possess an identical chromosome number. How?	2
12	In human births, there is an equal possibility of 50% chance for the arrival of a boy and a 50% chance for the birth of a girl. Explain.	2
13	'It is a possible that a trait is inherited but may not be expressed'. Give a suitable example to justify the above statement.	2

SECTION C

14	<p>(a) Why did Mendel choose garden pea for his experiments? Write two reasons.</p> <p>(b) List two contrasting visible characters of garden pea Mendel used for his experiment.</p>	3
15	<p>A person P has only Q chromosomes in all its gametes. On the other hand, another person R has chromosome S in half of its gametes and chromosome T in other half of gametes. When chromosomes Q and S combine during fertilisation, a female zygote result. On the other hand, combination of Q and T chromosomes produces a male zygote.</p> <p>a) What is chromosomes Q, S and T.</p> <p>b) Out of Q, S and T, which two chromosomes are of the same type? Which chromosome is smaller in size?</p> <p>c) What is the general name of chromosomes such as Q and T? Out of the two persons P and R, which one is male or female?</p>	3
16	<p>The couple is distressed by the fact that their new born doesn't resemble either of them. Out of curiosity they checked the blood type of the infant. It is type O. Because the father is type A and the mother is type B, they conclude that some confusion is there. Are they correct? Give reason for your answer.</p>	3
17	<p>In human beings, sex is genetically determined, mothers should not be blamed for giving birth to a girl child. As, both male and female babies have equal right to live and illegal absorption of female foetus is a crime.</p> <p>(a) What are sex chromosomes? How many chromosomes are present in a sperm and an ovum?</p> <p>(b) Why do all the gametes formed in human females have an X chromosome?</p> <p>(c) Explain how in sexually producing organisms the number of chromosomes in the progeny remains the same.</p>	5
18	<p>If we cross-bred tall (dominant) pea plants with pure-bred dwarf (recessive) pea plants, we will get F1 generation. If we now self-cross the pea plant of F1 generation, we obtain pea plants of F2 generation. (a) What name is given to such a type of cross?</p> <p>(b) Make a flow diagram showing a cross between the parents which give rise to F1 and F2 generation.</p> <p>(c) Write the genotype of (i) F1 generation (ii) F2 generation.</p> <p>(d) If we take round and wrinkled seeds, what will be the phenotypic ratio and genotypic ratio of F1 and F2 generation?</p>	5

19	<p>It has been established that in human beings, sex is genetically determined, mothers should not be blamed for giving birth to a girl child. Also, both male and female babies have equal right to live and illegal absorption of female foetus is a crime.</p> <p>(a) What are sex chromosomes? How many chromosomes are present in a sperm and an ovum?</p> <p>(b) Why do all the gametes formed in human females have an X chromosome?</p> <p>(c) Explain how in sexually producing organisms the number of chromosomes in the progeny remains the same.</p>	4
20	<p>Mehak has a tall pea plant. She wants to know whether it is a homozygous tall pea plant or homozygous pea plant.</p> <p>a) Design a test cross to verify it.</p> <p>b) Write the genotype of homozygous and heterozygous conditions.</p> <p>c) Write the recessive trait of height.</p>	4

ANSWER KEY

CHAPTER- 8 HEREDITY

Q NO	SECTION A	MARKS
1	(d) Equal chance of acquiring blood group A or blood group O.	1
2	(a) girl	1
3	(d) $TT : Tt : tt$	1
4	(a) 1 : 1	1
5	(c) $BB \times bb$	1
6	(c) Sexual reproduction	1
7	(d) A is False but R is true.	1
8	(b) Both A and R are true and R is not the correct explanation of A	1
9	<p>Sugarcane – asexual reproduction</p> <p>Human being – sexual reproduction</p>	2

10	The correct answer is trait B. In asexually reproducing organisms, the traits are passed onto the next generation with almost no changes. The trait which is passed on to a greater number of generations will exist and will express in a larger amount of population when compared to a newly expressed trait.	2
11	In sexually reproducing organisms, the gametes undergo meiosis, and hence, each gamete contains only half a set of chromosomes. When two gametes fuse, the zygote formed contains the full set of chromosomes. Hence, the formation of gametes by meiosis helps to maintain the same number of chromosomes in the progeny	2
12	In humans, sex determination is governed by the presence or absence of the Y chromosome. Individuals with XX chromosomes typically develop as females, while those with XY chromosomes typically develop as males. This determination occurs at the moment of fertilization when the sperm (carrying either an X or a Y chromosome) fertilizes the egg with an X chromosome, leading to the development of a female, or a Y chromosome, leading to the development of a male child.	2
13	Yes, it is possible that a trait is inherited but may not be expressed. For example, when pure tall pea plants are crossed with pure dwarf pea plants only tall pea plants are obtained in F1 generation. On selfing tall plants of F1 both tall and dwarf plants are obtained in F2 generation in the ratio 3: 1. Reappearance of the dwarf character a recessive trait in F2 generation shows that the dwarf trait was present in individuals of F1 but it did not express.	2
14	(a) Normally pea plant was self-fertilizing, because petals enclose the reproductive organs till fertilization. The self-fertilization through many generations helps in easily obtaining the pure line with constant trait in pea plants. The pea plant was easy to cultivate. (b) The two characteristics used by Mendel for his experiments were: (i) Tall and Dwarf Variety (ii) round and wrinkled seed coats.	3
15	Q-X chromosome, S-X chromosome, T-Y chromosome b) Q and S T-chromosome is smaller in size c) Sex chromosome P-Female, R-Male	3
16	No, the parents are not correct. The baby born to father having blood group A and mother having blood group B can have any one of the four possible blood groups- A, B, AB and O.	3
17	(a) Sex chromosomes are chromosomes that determine the sex of an organism. There is only one pair of sex chromosomes in a human cell. The 23rd pair of chromosomes are the sex chromosomes. Females have two	5

	<p>copies of the X chromosome (XX), while males have one X and one Y chromosome (XY). (b) Human females have the two X chromosomes called sex chromosomes as the 23rd pair of chromosomes. During meiosis at the time of gamete formation, one X chromosome enters each gamete. Hence all the female gametes possess an X chromosome. (c) In sexually reproducing organisms, the mother cells undergo meiosis, and hence, each gamete contains only one set of chromosomes. When two gametes fuse, the zygote formed contains the two set of chromosomes. Hence, the formation of gametes by meiosis helps to maintain the same number of chromosomes in the progeny.</p>	
18	<p>(a) Monohybrid cross (b) Draw the cross (c) F1 - Tt :Tt F2 - TT: Tt: tt (d) F1- Phenotypic 1:1 Genotypic-Rr:Rr (e) F2 - Phenotypic 3:1 Genotypic- 1: 2: 1 -RR:Rr:rr</p>	5
19	<p>(a) Sex chromosomes are chromosomes that determine the sex of an organism. There is only one pair of sex chromosomes in a human cell. The 23rd pair of chromosomes are the sex chromosomes. Females have two copies of the X chromosome (XX), while males have one X and one Y chromosome (XY).</p> <p>(b) Human females have the two X chromosomes called sex chromosomes as the 23rd pair of chromosomes. During meiosis at the time of gamete formation, one X chromosome enters each gamete. Hence all the female gametes possess an X chromosome.</p> <p>(c) In sexually reproducing organisms, the mother cells undergo meiosis, and hence, each gamete contains only one set of chromosomes. When two gametes fuse, the zygote formed contains the two sets of chromosomes. Hence, the formation of gametes by meiosis helps to maintain the same number of chromosomes in the progeny.</p>	4

CHAPTER- 9 LIGHT - REFLECTION AND REFRACTION

Q NO	SECTION A	MAR KS
1	<p>What causes the convex mirror to always form a virtual image?</p> <p>(a) Because the reflected ray never intersects</p> <p>(b) Because the reflected ray converges at a single point</p> <p>(c) Because the incident ray traces its path back along the principal axis</p> <p>(d) Because the incident ray of a convex mirror gets absorbed in the mirror</p>	1
2	<p>The image formed by a concave mirror is real, inverted and of the same size as that of the object. The position of object should be</p> <p>(a) at the focus</p> <p>(b) at the centre of curvature</p> <p>(c) between focus and centre of curvature</p> <p>(d) beyond centre of curvature</p>	1
3	<p>A converging mirror has a radius of curvature 20 cm, to obtain a virtual image, at what distance should the object be placed in front of the mirror.</p> <p>(a) the object should be placed at focus of the mirror</p> <p>(b) between 0 cm and 10 cm</p> <p>(c) between 10 cm and 20 cm</p> <p>(d) at 20 cm</p>	1
4	<p>A diverging lens will produce</p> <p>(a) always real image</p> <p>(b) always virtual image</p> <p>(c) both real and virtual image</p> <p>(d) none of these</p>	1
5	<p>The laws of reflection hold true for (CBSE DELHI 2020)</p> <p>(a) plane mirrors only</p> <p>(b) concave mirrors only</p> <p>(c) convex mirrors only</p> <p>(d) all reflecting surfaces</p>	1

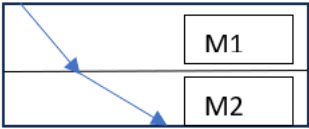
6	<p>There is no change in the path of the ray of light entering from one medium to another. What do you infer from the statement?</p> <p>(a) Both the medium has same optical densities (b) Both medium are opaque (c) Both medium have different refractive indices (d) None of the above</p>	1
	<p>Following questions (7&8) consist of two statements – Assertion (A) and Reason (R). Answer these questions selecting the appropriate option given below:</p> <p>(a) Both A and R are true and R is the correct explanation of A. (b) Both A and R are true but R is not the correct explanation of (c) A is true but R is false. (d) A is false but R is true.</p>	
7	<p>Assertion(A) : The centre of curvature is not a part of the mirror. It lies outside its reflecting surface.</p> <p>Reason (R) : The reflecting surface of a spherical mirror forms a part of a sphere. This sphere has a centre.</p>	1
8	<p>Assertion(A) : Light travels faster in glass than in air.</p> <p>Reason (R) : Glass is denser than air.</p>	1
SECTION B		
9	<p>One-half of a convex lens is covered with a black paper. Will this lens produce a complete image of the object? Verify your answer experimentally. Explain your observations. (NCERT EXERCISE QUESTION NO: 9)</p>	2
10	<p>The picture below shows the path of light ray as it travels from one medium to another</p>  <p>What could be your possible conclusion in terms of the optical densities of medium 1 and 2, justify your answer with appropriate reason.</p>	2
11	<p>(a)When the object is positioned at the centre of curvature of a concave mirror, what kind of image is formed, and what would be its image position.</p>	2
12	<p>What is meant by the power of a lens? Write its SI unit</p>	2

13	<p>A student while conducting an experiment with a converging mirror if expects to get an erect image of an object of focal length 20 cm,</p> <p>(a) specify the range of distance where the object should place in front of the mirror</p> <p>(b) State one use of the mirror based on the above kind of image formation.</p>	2
SECTION C		
14	<p>Vedant went to a palmist to show his palm. The palmist used a special lens for this purpose. (CBSE OD SET 1 2020)</p> <p>(a) what could be the nature of the lens used by the palmist, give reason to justify your answer. (2m)</p> <p>(b) To get a virtual and magnified image of the object, where should the palmist place/hold the lens. Draw a ray diagram for such position (1m)</p>	3
15	<p>(a) While visiting a science fair, an observer is standing in front of a magic mirror, finds the image of his/her head bigger, the middle portion of his/her body the same size and that of the legs smaller, all erect images. what could be the possible mirror combination used to create such a mirror</p>	3
16	<p>It was experimentally found that the speed of light in a medium was half the speed of light in air, and calculated the value of the refractive index of the medium with respect to air.</p>	3
SECTION D		
17	<p>(a) Define Principal focus of a spherical lens</p> <p>(b) what do you understand about the term Optical centre.</p> <p>(c) An object of height 6 cm is placed perpendicular to the principal axis of a concave lens of focal length 5 cm. Use lens formula to determine the position, size and nature of the image if the distance of the object from the lens is 10 cm. (Delhi 2013)</p> <p>(d) Write the relationship among the object distance (u), image distance (e) and the focal length (f) of the Spherical lens</p>	5
18	<p>(a) In the observed phenomena of refraction of light through a rectangular glass slab, how does the speed of light change as it passes through a pair of media (air to glass)</p> <p>(b) Do you think there could be any relation between the amount of deviation the light ray undergoes and the thickness of the glass slab. Justify your answer with a proper reasoning. Can the conclusion be experimentally verified?</p> <p>(c) What is Snell's Law of refraction?</p>	5

SECTION E

19	<p>The image of an object formed by a convex lens may be real/virtual; erect/inverted; smaller/larger than the object. It would depend upon the distance of the object from the lens, however, the image of an object formed by a concave lens is always virtual, erect and smaller in size than the object.</p> <p>(a) in order to get a virtual image of an object, where should it be placed in front of a concave lens.</p> <p>(b) Where should an object be placed in front of a convex lens to obtain an image of the same size as the object?</p> <p>(c) It was observed that for a particular object distance, a highly diminished real image is formed, what could be the lens for which this kind of image is formed, and what could be the position of the object for obtaining such image.</p> <p>(ii) The type of lens that does not form a real image for any position of the object would be</p>	4
20	<p>A subject mentor, in order to show his/her students the images of insects that he/she investigated in the lab, she brought a slide projector that produces 400 times enlarged and inverted images of a slide on a screen 5 m away.</p> <p>(a) For the slide projector to produce a real inverted and enlarged image, what kind of lens should be used? (1m)</p> <p>(b) the image distance is represented by 'V', object distance represented by 'u', with one reason state what will be the sign for V/u in the given case? (1m)</p> <p>(c) A slide projector has a convex lens with a focal length of 25 cm. The slide is placed upside down at 30 cm from the lens. How far away should the screen be placed from the slide projector's lens so that the slide is in focus? (2m)</p>	4

CHAPTER- 9 LIGHT: REFLECTION AND REFRACTION

Q. NO	ANSWER/RESPONSE	MARKS
1	(a)	1m
2	(b)	1m
3	(b)	1m
4	(b)	1m
5	(d)	1m
6	(a)	1m
7	(a)	1m
8	(d)	1m
9	Yes, it will produce complete image of the object, this can be verified experimentally by observing the image formed by a convex lens where half of it is covered with black paper, image is formed, but the intensity of the image would be less.	2m
10	Optical density of medium 1 is greater than optical density of medium 2 as the light ray is bending away from the normal.	2m
11	(a) real and inverted (b) at C	$\frac{1}{2} + \frac{1}{2}$ 1
12	Ability to converge/diverge light ray passing through it/ reciprocal of focal length $P=1/f$ SI unit of power is Dioptre	1m 1m
13	(a) Object should be placed at a distance between 0-20 cm as it would give a virtual and erect image (b) Used as a shaving mirror/mirror used by dentist to get enlarged image of teeth.	1m 1m
14	(a) Nature of the lens is convex. It is used to provide a magnified image of the palm (b) the object should be placed between the focus and the optical centre of the lens	1m 1m + 1m

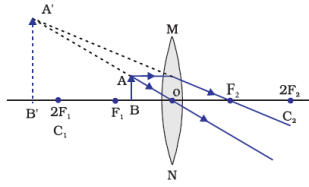

(Diagram Ref: NCERT Text book)

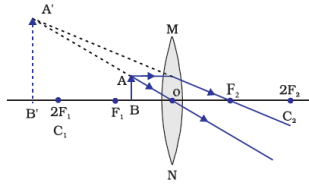
	 <p>(Diagram Ref: NCERT Text book)</p>	
15	<p>Head bigger – concave mirror</p> <p>Middle part same size – plane mirror</p> <p>Legs smaller – convex mirror</p>	<p>1m</p> <p>1m</p> <p>1m</p>
16	<p>Speed of light in a medium = $\frac{1}{2}$ speed of light in Air</p> <p>Refractive index of the medium = Speed of light in air/ Speed of light in medium</p> <p>Let speed of light in air be ‘x’</p> <p>\Rightarrow R.I of the medium = $x/x/2$</p> <p>\Rightarrow Refractive index of the medium = 2</p>	<p>$\frac{1}{2}$ m</p> <p>$\frac{1}{2}$ m</p> <p>2 m</p>
17	<p>(a) The principal focus of a lens is a point on its principal axis wherein the rays of light parallel to it and after passing through it converge (for a convex lens) or appear to diverge (for a concave lens)</p> <p>(b) Optical centre is the point in the middle of the lens through which a ray of light can pass without any deviation.</p> <p>(c) Focal length of the lens , $f = -5$ cm</p> <p>Distance , $u = -10$ cm, object size, $h = 6$ cm</p> <p>Image distance $V = ?$</p> <p>$1/f = 1/V - 1/u$</p> <p>$\Rightarrow 1/V = 1/-5 + 1/-10 = -3/10$</p> <p>$\Rightarrow V = - 10/3 = - 0.33$ cm</p> <p>Magnification $m = V/u = -3.33/10 = 0.33$</p> <p>$m$ is positive implies that image is virtual and erect, the magnitude of ‘m’ also implies that the image is diminished.</p> <p>$m = V/u = h'/h \Rightarrow 1/3 = h'/6$</p> <p>$h' = 2$ cm</p> <p>(d) $1/f = 1/V - 1/u$</p>	<p>1m</p> <p>1 m</p> <p>2 m</p>

		1m
18	<p>(a) When light passes through a glass slab, it undergoes refraction due to the change in the speed of light between air and glass. As the light enters the glass from air, it slows down because the speed of light is lower in glass than in air. This causes the light ray to bend towards the normal. Upon exiting the glass slab back into air, the light speeds up, causing the ray to bend away from the normal. The phenomenon demonstrates how the speed of light changes in different media, leading to the bending of light rays.</p> <p>(b) The lateral displacement of a light ray passing through a glass slab is directly proportional to the thickness of the slab. As the thickness of the glass slab increases, the lateral displacement also increases. Experimental verification</p> <p>(c) The ratio of sine of angle of incidence to the sine of angle of refraction is a constant, for the light of a given colour and for the given pair of media. (Ref: NCERT Text Book)</p>	<p>2m</p> <p>1m + 1m</p> <p>1m</p>
19	<p>(a) Any distance from the lens</p> <p>(b) At 2F</p> <p>(c) (i) object at infinity, convex lens</p> <p>(ii) object at infinity, Concave lens</p>	<p>1m</p> <p>1m</p> <p>1/2m+</p> <p>1/2m</p> <p>1/2m+</p> <p>1/2m</p>
20	<p>(a) convex lens</p> <p>(b) Negative, as the image is real and inverted</p> <p>(c) $1/f = 1/V - 1/u$ $\Rightarrow 1/25 = 1/V - (1/-30)$ $\Rightarrow 1/V = 1/25 - 1/30$ Therefore V = 150 cm</p>	<p>1m</p> <p>$\frac{1}{2} m + \frac{1}{2} m$</p> <p>2m</p>

CHAPTER- 10 HUMAN EYE AND THE COLOURFUL WORLD

Q NO	SECTION A	MARKS
1	<p>How does the human eye regulate the amount of light entering the eye?</p> <p>A. Ciliary muscles contracts the pupil in case of bright light and expands in case of dim light.</p> <p>B. Iris expands the pupil in case of bright light and contracts it in case of dim light.</p> <p>C. Iris contracts the pupil in case of bright light and expands it in case of dim light.</p> <p>D. Ciliary muscles elongate the lens in case of bright light and contracts it in case of dim light.</p>	1
2	<p>Sometimes the crystalline lens at old age becomes cloudy and opaque. What is this condition called?</p> <p>A. Myopia</p> <p>B. Hypermetropia</p> <p>C. Cataract</p> <p>D. Presbyopia</p>	1
3	<p>The near point of a person is 40cm in front of the eye. What is the nature and power of lens required to correct the problem?</p> <p>A. Concave, -2.5D</p> <p>B. Convex, 2.5D</p> <p>C. Concave, 2.5D</p> <p>D. Convex, -2.5D</p>	1
4	<p>A triangular glass prism has</p> <p>A. 2 lateral surfaces and 2 triangular bases</p> <p>B. 3 lateral surfaces and 3 triangular bases</p> <p>C. 2 lateral surfaces and 3 triangular bases</p> <p>D. 3 lateral surfaces and 2 triangular bases</p>	1
5	<p>How are the angle of incidence, angle of refraction and angle of emergence related when a ray of light passes through a rectangular glass slab?</p>	1

	<p>A. Angle $i < \text{angle } e < \text{angle } r$</p> <p>B. Angle $i > \text{angle } e > \text{angle } r$</p> <p>C. Angle $i = \text{angle } e < \text{angle } r$</p> <p>D. Angle $i = \text{angle } e > \text{angle } r$</p>	
6	<p>For what extra time are we able to see the daylight?</p> <p>A. 2 minutes</p> <p>B. 8 minutes</p> <p>C. 4 minutes</p> <p>D. 10 minutes</p>	1
7	<p>For question no 7 and 8, select the appropriate option from the following</p> <p>A. Both assertion and reason are correct and reason is the correct explanation of assertion.</p> <p>B. Both assertion and reason are correct but reason is not the correct explanation of assertion.</p> <p>C. Assertion is true and reason is false.</p> <p>D. Assertion is false but reason is true.</p> <p>Assertion-A person cannot see distant objects kept beyond 4 m because is suffering from myopia.</p> <p>Reason- Myopia is caused due to the appearance of a cloudy layer over the eye lens.</p>	1
8	<p>Assertion- Shambhu is unable to see the tree placed at a distance of 15 metre on an early morning of winter season due to fog.</p> <p>Reason- Light is scattered by the droplets present in the atmosphere.</p>	1
SECTION B		
9	<p>Thomas, a class 8th student, was once playing with his pet animal. He observed the position of the eyes of his pet. He was amused to see that the two eyes of his pet are positioned on either sides of the head unlike humans. Which pet does Thomas have? What are the advantages of having such a position?</p>	H
10	<p>Raghu needs a lens of power +4 D for correcting his near vision and -4 D for correcting his distant vision. Calculate the focal lengths of both the lenses required to correct these defects</p>	2
11	<p>Make the comparison between the following:</p> <p>A. Angle of incidence and angle of emergence</p>	2

	B. Angle of prism and angle of deviation	
12	Illustrate the phenomenon of dispersion through a glass prism.	2
13	Poornima observed that objects seen through a turbulent stream of hot air rising above a fire tend to flicker or waver. Support this statement with a proper argument and provide two examples seen in daily life for this phenomenon.	2
	SECTION C	
14	Construct an activity to show refraction of light through a triangular glass prism along with the diagram.	3
15	A. Arrange the colours of the rainbow in increasing order of their frequencies. B. Sheena took two glass prisms and tried to split the colours of spectrum further by placing a second identical prism next to the first one. Instead of further splitting, she found a beam of white light emerging from the other side of the second prism. Sketch a diagram to show the same.	3
16	Shubham wears a shirt with the same colour as that of a ripened tomato on a sunny day. His friend Karan is able to identify him from a distance of 120 meter Which physical phenomena is inferred from this information? Explain.	3
	SECTION D	
17	A. Why do different colours deviate differently when passed through a triangular glass prism? B. Arrange the phenomenon happening in rain drop in the correct sequence: internal reflection, dispersion, refraction C. Demonstrate the dispersion of white light through a glass prism.	5
18	A) X uses a lens of power -2D and Y uses a lens of power +4D. Calculate the power of lenses used by X and Y respectively. B) Revant, aged 49 years, is unable to see the things at a distance beyond 100 metres. Also, he is unable to read the newspaper properly. Design a corrective eye lens for Revant. Predict the disease he is suffering from.	5
	SECTION E	
19	Scattering of light: Whether the colour of the ocean and the colour of the sky are related? In both the cases, the preferential absorption of long wavelength light gives rise to blue. The Ocean looks blue, the blue wave length returned predominantly than longer wave length. Note that this effect only works if the water is very pure. Perhaps the most helpful response came from	4

	<p>Michael Kruger of the department of physics at university of Missouri. The sky is blue not because the atmosphere absorbs the other colors, but the atmosphere tends to scatter shorter wavelength light to a greater extent than longer wavelength light. When you look up day time sky you see blue no matter where you look. This scattering is called Rayleigh scattering. The amount of light scattering goes as the frequency of the light to fourth power. Nitrogen and Oxygen molecules are smaller than the wavelength of light and cannot cause scattering. Same way we can think about whiteness of milk.</p> <p>(a) Suggest two examples from your surroundings where you can see scattering of light.</p> <p>(b) Design a diagram to show scattering of light through a tumbler containing milk.</p> <p>(c) Assess the type of solution giving rise to scattering of light along with its two properties. Also suggest a term for this phenomenon.</p>	
20	<p>The light rays coming from the object kept in front of us enter through the cornea of the eye, pass through the pupil of the eye and fall on the eye-lens. The eye-lens is a convex lens, which produces a real and inverted image of the object on the retina. The cornea acts as the eye's outermost lens. It functions like a window that controls and focuses the entry of light into the eye. The ciliary muscle enables accommodation of the eye. The retina captures the light that enters your eye and helps translate it into the images you see.</p> <p>(a) What component ensures the image is sharply focused on the retina, and what is its mechanism for achieving this clarity?</p> <p>(b) What components of the eye are responsible for converging rays of light onto the retina?</p> <p>(c) When an object is brought closer to the eye, what adjustments does the eye need to make to maintain a sharp focus on the image?</p>	4

ANSWER KEY CHAPTER- 10 HUMAN EYE AND THE COLOURFUL WORLD

Q NO	SECTION A	MARKS
1	(c) Iris contracts the pupil in case of bright light and expands it in case of dim light.	1
2	(c) Cataract	1
3	(b). Convex, 2.5D	1
4	(d) 3 lateral surfaces and 2 triangular bases	1

5	(d) Angle $i = \text{angle } e > \text{angle } r$	1
6	(c). 4 minutes	1
7	(c). Assertion is true and reason is false	1
8	(a). Both assertion and reason are correct and reason is the correct explanation of assertion	1
SECTION B		
9	Any animal with the eyes on the sides; Eyes on the side of the head give prey a larger field of vision whereas eyes in humans give a wider field of vision. It also helps us perceive the depth which forms a 3D impression and enhances the ability of assessing distinct positions of objects.	$\frac{1}{2} + 1.5$
10	$P = 1/f$ $f_1 = 1/4 \quad f_2 = -1/4$ $f_1 = +0.25\text{m} \quad f_2 = -0.25\text{m}$	$\frac{1}{2}$ $\frac{1}{2}$ $\frac{1}{2} + \frac{1}{2}$
11	A. The angle formed between the normal and the incident ray at the point of incidence whereas angle of emergence is the angle between the emergent ray and the normal (at the point of emergence) to the surface from which it is emerging. B. The angle between the two lateral faces of a prism is called the angle of the prism or the prism angle. When the light ray is allowed to pass through the prism, it makes the emergent ray bend at an angle to the direction of the incident ray. This angle is called the angle of deviation for the prism.	1 1
12	Refer to figure 10.5 NCERT page no 166; Diagram + labelling	1+1
13	The objects seen through a turbulent stream of hot air rising above a fire tend to flicker or waver because of atmospheric refraction. The hot air just above the fire is less dense than the cooler air above it. Since the physical conditions of air are not stationary, the apparent position of the object fluctuates. Ex : Twinkling of stars, early sunrise and delayed sunset	1+1
SECTION C		
14	Refer to Activity 10.1 NCERT page no 16	3
15	a. Red, Orange, Yellow, Green, Blue, Indigo, Violet b. Diagram of recombination of spectrum of light	1 2
16	Scattering of light Karan was able to see him from a distance because of red colour as red colour has maximum wavelength so it is least scattered.	1 2

SECTION D		
17	<p>a. The different colours have different wavelengths and have different speeds in a certain medium.</p> <p>b. refraction, dispersion, internal reflection</p> <p>c. Refer to figure 10.5 NCERT page no 166</p>	<p>1+1</p> <p>1</p> <p>1+1</p>
18	<p>$P = 1/f$ or $f = 1/P$</p> <p>$F_1 = -1/2 = -0.5m$ $f_2 = +1/4 = +0.25m$</p> <p>Corrective lens – bifocal lens</p> <p>Relevant diagram</p> <p>Defect he is suffering from = Presbyopia</p>	<p>1</p> <p>$\frac{1}{2} + \frac{1}{2}$</p> <p>1</p> <p>1</p> <p>1</p>
SECTION E		
19	<p>(a) Sunlight entering into a dark room; in foggy weather, beams of headlights are clearly visible(any two).</p> <p>(b) Relevant diagram showing scattering of light with path of light becoming visible</p> <p>(c) Colloids/ colloidal solution, any two properties of colloids; Tyndall effect</p>	<p>$\frac{1}{2} + \frac{1}{2}$</p> <p>$\frac{1}{2} + \frac{1}{2}$</p> <p>2</p>
20	<p>(a) Eye lens; By changing its thickness and hence its converging power</p> <p>(b) Cornea and Eye lens</p> <p>(c) Ciliary muscles should change the shape of eye-lens/Focal length to make it thicker and increase its converging power.</p>	<p>$\frac{1}{2} + \frac{1}{2}$</p> <p>$\frac{1}{2} + \frac{1}{2}$</p> <p>2</p>

CHAPTER – 11 ELECTRICITY

Q NO	SECTION A	MARKS
1	<p>In what way we can express current?</p> <p>a) $I=H^2RT$</p> <p>b) $I=Qt$</p> <p>c) $I=VR$</p> <p>d) $I=Q/t$</p>	1
2	<p>We say potential difference to be one volt</p> <p>a) When 1kJ of work is done to move a charge of 1C</p> <p>b) When 1kJ of work is done to move a charge of 1milliC</p> <p>c) When 1J of work is done to move a charge of 1C</p> <p>d) When 2kJ of work is done to move a charge of 2C</p>	1
3	<p>How much is the potential difference applied across the circuit where 48J of work is done to move a charge of 3 coulomb?</p> <p>a) 6V</p> <p>b) 60V</p> <p>c) 16V</p> <p>d) 26V</p>	1
4	<p>Relate length of the wire and area of cross-section with the resistance of a wire.</p> <p>a) Resistance is inversely proportional to length and directly proportional to area of cross section</p> <p>b) Resistance is directly proportional to length and directly proportional to area of cross section</p> <p>c) Resistance is inversely proportional to length and directly proportional to area of cross section</p> <p>d) Resistance is directly proportional to length and inversely proportional to area of cross section</p>	1
5	<p>How is temperature and resistance related to each other?</p> <p>a) Resistance increases on decreasing temperature</p> <p>b) Resistance decreases on increasing temperature</p> <p>c) Resistance increases on increasing temperature</p> <p>d) Not related</p>	1

6	<p>How is one unit of energy expressed in terms of kilojoules?</p> <p>a) 1kWh= 36kJ b) 1kWh= 3600 kJ c) 1kWh= 3.6kJ d) 1kWh= 360kJ</p>	1				
7	<p>For questions 7 and 8, select the correct options where options are as follows:</p> <p>a) Both assertion and reason are correct and reason is the correct explanation of assertion. b) Both assertion and reason are correct and reason is not the correct explanation of assertion. c) Assertion is true but reason is false. d) Assertion is false but reason is true.</p> <p>Assertion: Tungsten, a non-metal is used for making bulb filaments. Reason: Tungsten has high melting point.</p>	1				
8	<p>Assertion: Resistance of a wire increases to double when length is doubled. Reason: Resistance is inversely proportional to the area of cross section of the wire.</p>	1				
SECTION B						
9	Calculate the amount of current drawn by a geyser for 10 minutes if 3600C of charge flows through it.	2				
10	Ravi brings a device which shows a numerical value in volts when connected in a circuit. He also brought another electrical component of 1.5V which is creating a potential difference in the circuit. Identify the two devices and write their symbols	2				
11	<p>Reema is using an electric rice cooker to cook rice for a party at her home. While cooking, she found that the cooker stopped working suddenly.</p> <p>A. What is the scientific concept involved in for cooking rice in rice cooker? B. What could be the possible reason due to which cooker stopped working when Reema was cooking?</p>	2				
12	<p>Analyse the given data and plot a graph between potential difference and current:</p> <table border="1" style="margin-left: auto; margin-right: auto;"> <thead> <tr> <th>Potential Difference</th> <th>Current</th> </tr> </thead> <tbody> <tr> <td>0</td> <td>0</td> </tr> </tbody> </table>	Potential Difference	Current	0	0	2
Potential Difference	Current					
0	0					

1	2
2	4
3	6
4	8

Also, find the amount of resistance experienced by the wire.

13	A nichrome wire of length 2m and area of cross section 1 m^2 is connected in a circuit. Another wire of same material having 4m length with area of cross section 4m^2 is connected in a separate circuit. Compare the two resistances in terms of their ratio.	2															
SECTION C																	
14	a) Compare the amount of charge that is flowing through two bulbs X and Y if X draws a current of 5A and Y draws a current of 7A for 5 minutes and 3 minutes respectively. b) Determine the power consumption by an electric geyser for the month of February 2024 if it takes 10A of current from a 240V line and used for 2 hours a day.	3															
15	a) Design a circuit diagram using following electrical components so that there is minimum overall resistance: 5ohm resistor, 10 ohm resistor, a plug key, ammeter, voltmeter, a battery of 4V. b) Arrange the three resistors of 4ohm each in such a manner so as to obtain the total resistance in the circuit as: A. 6 ohm B. 1.1 ohm	3															
16	Shyam made 4 electric circuits using 4 different conductors of same length and area of cross section. He then obtained various values of V and I as given below. He also classified the conductors as good and bad with the benchmark resistance as 10ohm. Evaluate the type of conductor in terms of good and bad on the basis of information given. <table style="margin-left: auto; margin-right: auto;"> <thead> <tr> <th></th> <th>V</th> <th>I</th> </tr> </thead> <tbody> <tr> <td>A</td> <td>55</td> <td>11</td> </tr> <tr> <td>B</td> <td>240</td> <td>15</td> </tr> <tr> <td>C</td> <td>90</td> <td>10</td> </tr> <tr> <td>D</td> <td>144</td> <td>8</td> </tr> </tbody> </table>		V	I	A	55	11	B	240	15	C	90	10	D	144	8	3
	V	I															
A	55	11															
B	240	15															
C	90	10															
D	144	8															
SECTION D																	

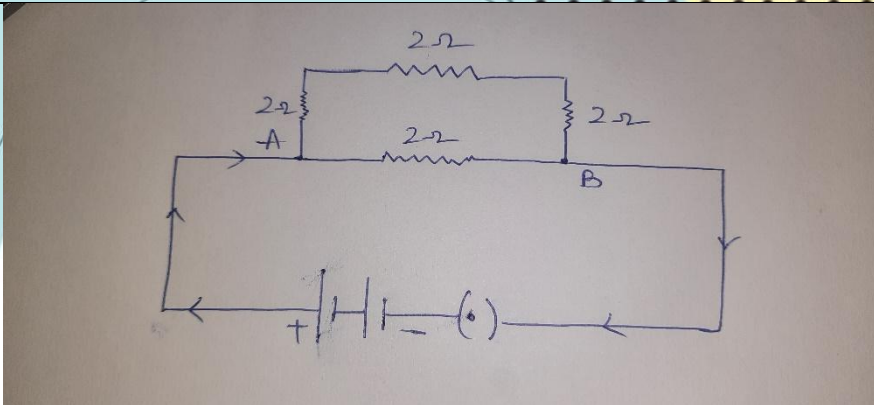
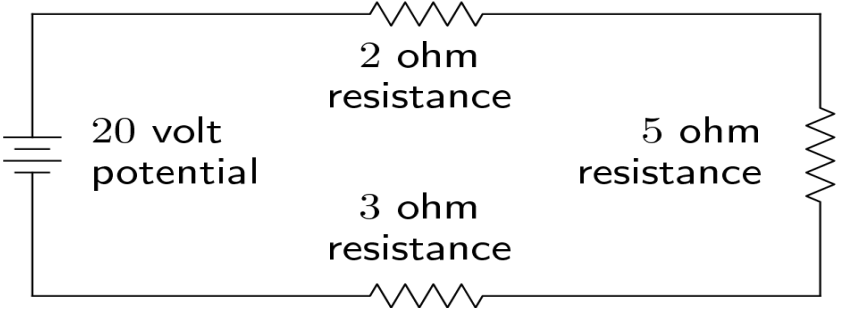
17	 <p>A. For the combination of resistors shown in figure, calculate the equivalent resistance between A and B.</p> <p>B. Why is it impractical to connect the household devices in series?</p> <p>C. Explain the working of fuse in an electric circuit.</p>	5
18	<p>A. A charge of 5C is moving across the two points having potential difference 12V and 8V respectively in an electric circuit. Compute the work done.</p> <p>B. A tungsten wire of length 5metre with specific resistance 5.2×10^{-8} ohm meter having area of cross section 2metre square is connected in a circuit. What would be the resistance of this wire?</p> <p>C. How would the resistance change if length of the wire becomes twice of its original length? Illustrate with the calculation.</p>	5
SECTION E		
19	 <p>(Source: https://www.google.com/url?sa=i&url=https%3A%2F%2Fcommons.wikimedia.org%2Fwiki%2FFile%3ALinalg_resisters_in_series.png&psig=AOvVaw0ZDHuuo4DxVHOSn_7o7iT&ust=1702623304099000&source=images&cd=vfe&opi=89978449&ved=0CBIOjRxqFwoTCIDu6dqjtjoMDFQAAAAAdAAAAABAD)</p> <p>A. Estimate the value of total current flowing in the given circuit.</p> <p>B. Assess the impact of removing the 5ohm resistance on the current flowing in the circuit.</p> <p>C. At what rate, the energy is being dissipated by 3ohm resistance?</p>	4

ANSWER KEY CHAPTER- 11 ELECTRICITY

Q NO	SECTION A	MARKS
1	d) $I=Q/t$	1
2	c) When 1J of work is done to move a charge of 1C	1
3	c) 16V	1
4	d) Resistance is directly proportional to length and inversely proportional to area of cross section	1
5	c) Resistance increases on increasing temperature	1
6	b) 1kWh= 3600 kJ	1
7	d) Assertion is false but reason is true.	1
8	b) Both assertion and reason are correct and reason is not the correct explanation of assertion	1
	SECTION B	
9	$I=Q/t$; $t=10\text{min} \times 60 = 600\text{s}$ $I= 3600/600 = 6\text{A}$	4 x 1/2
10	Device which shows a numerical value in volts = Voltmeter Electrical component which is creating a potential difference= Battery/Cell; Relevant symbols for both	4 x 1/2
11	A. Heating effect of current/Joule's law of heating B. Short circuit/drop in voltage (any one)	1+1
12	Straight line graph; $R=V/I = \frac{1}{2}=0.5 \text{ Ohm}$	1 $\frac{1}{2}+\frac{1}{2}$
13	$R_1=pl_1/A_1$; $R_2=pl_2/A_2$ $R_1=p \times 2/1$; $R_2=p \times 4/4$ $R_1/ R_2= p \times 2/1 / p \times 4/4$ $R_1/ R_2= 2:1$	$\frac{1}{2} + \frac{1}{2}$ $\frac{1}{2}$ $\frac{1}{2}$
	SECTION C	
14	a) $Q=It$ $t_1 = 5\text{min} \times 60 = 300\text{s}$ $t_2 = 3\text{min} \times 60 = 180\text{s}$ $Q_1=I_1t_1$; $Q_2=I_2t_2$ $Q_1= 5 \times 300$ $Q_2= 3 \times 180$ $Q_1= 1500\text{C}$ $Q_2= 1260\text{C}$ c) Energy = $Vit = 139.2 \text{ KWh}$	$\frac{1}{2}$ $\frac{1}{2}+\frac{1}{2}$ $\frac{1}{2}$ $\frac{1}{2}+\frac{1}{2}$

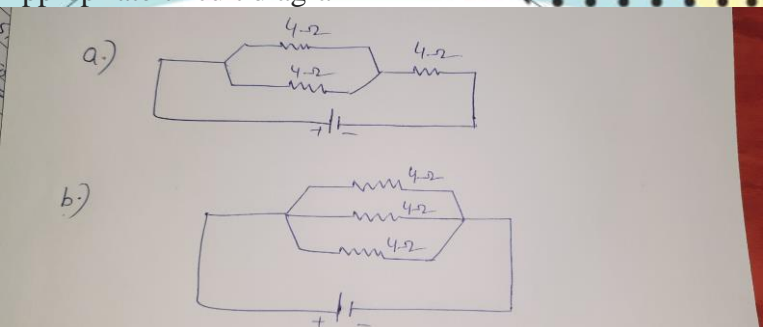
15	<p>a) Appropriate circuit diagram</p>  <p>b)</p>	1 1+1
16	<p>$R = V/I$ $R_1 = 55/11 = 5 \text{ ohm}$ $R_2 = 240/15 = 16 \text{ ohm}$ $R_3 = 90/10 = 9 \text{ ohm}$ $R_4 = 144/8 = 18 \text{ ohm}$ Good conductor = 1 and 3 as they are offering lesser resistances.</p>	$\frac{1}{2}$ $\frac{1}{2} + \frac{1}{2}$ $\frac{1}{2}$ 1
SECTION D		
17	<p>A. $R_1 = 2 + 2 + 2 = 6 \text{ ohm}$ $1/R_{\text{eqv}} = 1/6 + 1/2 = 1.5 \text{ ohm}$</p> <p>B. (1) The effective resistance will increase as a result the current will fall, and therefore the power through each device will also drop. (2) If one appliance blows a fuse, the others will not turn on.</p> <p>C. An electric fuse is a safety device which prevents damages to electrical circuits and possible fires. If a current larger than the specified value flows through the circuit, the temperature of the fuse wire increases. This melts the fuse wire and breaks the circuit.</p>	$\frac{1}{2}$ $\frac{1}{2}$ 1+1 1+1
18	<p>A. $V = W/Q$ $W = (V_2 - V_1) \times Q$ $= (12 - 8) \times 5$ $= 4 \times 5 = 20 \text{ J}$</p> <p>B. $R = \rho l/A$ $R = 5.2 \times 10^{-8} \times 5/2$ $= 7.8 \times 10^{-8} \text{ ohm}$</p> <p>C. If the length of a wire is doubled by taking more of wire, the resistance is doubled. $R_1 = \rho l_1/A_1$; $R_2 = \rho 2 \times l_1 / A_2$ $R_1/R_2 = 1/2$</p>	$\frac{1}{2}$ $\frac{1}{2} + \frac{1}{2}$ $\frac{1}{2}$ $\frac{1}{2}$ $\frac{1}{2}$ 1+1
SECTION E		
19	<p>A. $R = R_1 + R_2 + R_3$ $R = 2 + 5 + 3 = 10 \text{ ohm}$</p> <p>B. Total resistance, $R = R_1 + R_2$ $2 + 3 = 5 \text{ ohm}$ As the resistance decreases the amount of current will increase in the circuit.</p>	$\frac{1}{2}$ $\frac{1}{2}$ $\frac{1}{2}$ $\frac{1}{2}$

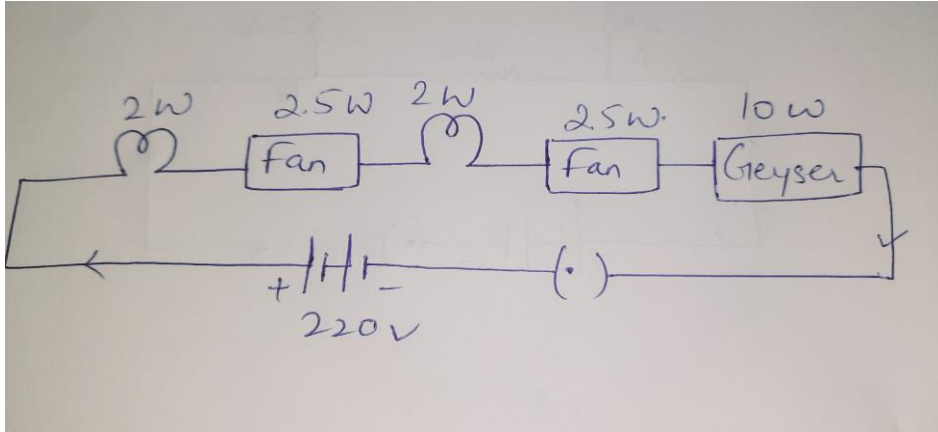
	<p>C. Rate of energy dissipated, power = VI</p> <p>$I = V/R_{eqv} = 20/10 = 2 \text{ A}$</p> <p>$R = 3 \text{ ohm}$</p> <p>V for 3 ohm = $2 \times 3 = 6 \text{ V}$</p> <p>$P = 6 \times 2 = 12 \text{ W}$</p>	<p>$\frac{1}{2}$</p> <p>$\frac{1}{2} + \frac{1}{2}$</p> <p>$\frac{1}{2}$</p> <p>$\frac{1}{2}$</p> <p>$\frac{1}{2}$</p>
20	<p>A). $H = I^2 R t$</p> <p>$t = 30 \times 60 = 1800 \text{ s}$</p> <p>$H = 6 \times 6 \times 5 \times 1800 = 324000 \text{ J} = 324 \text{ kJ}$</p> <p>B). $E = Pt$</p> <p>$= 0.15 \times 2 = 0.3 \text{ kWh}$</p> <p>Cost = Rs. $8 \times 0.3 = \text{Rs. } 2.4$</p> <p>C.</p>  <p>The diagram shows a series circuit connected to a 220V AC source. The components in the circuit are, from left to right: a 2W resistor, a 2.5W fan, a 2W resistor, another 2.5W fan, and a 10W geyser. The current flows from the positive terminal of the source through these components in series.</p>	<p>$\frac{1}{2}$</p> <p>$\frac{1}{2} + \frac{1}{2}$</p> <p>$\frac{1}{2}$</p> <p>$\frac{1}{2}$</p> <p>$\frac{1}{2}$</p> <p>2</p>

CHAPTER- 12 MAGNETIC EFFECT OF CURRENT

Q NO	SECTION A	MARKS
1	<p>A strong bar magnet is placed vertically above a horizontal wooden board. The magnetic lines of force will be:</p> <p>a) Only in the horizontal plane around the magnet</p> <p>b) Only in the vertical plane around the magnet</p> <p>c) In horizontal as well as vertical planes around the magnet</p> <p>d) In all the planes around the magnet</p>	1
2	<p>For a current in a long straight solenoid N- and S-poles are created at the two ends. Among the following statements, the incorrect statement is ((NCERT exemplar)</p> <p>a. The field lines inside the solenoid are in the form of straight lines which indicates that the magnetic field is the same at all points inside the solenoid</p> <p>b. The strong magnetic field produced inside the solenoid can be used to magnetize a piece of magnetic material like soft iron, when placed inside the coil</p> <p>c. The pattern of the magnetic field associated with the solenoid is different from the pattern of the magnetic field around a bar magnet</p> <p>d. The N- and S-poles exchange position when the direction of current through the solenoid is reversed</p>	1
3	<p>The most important safety method used for protecting home appliances from short circuiting or overloading is (NCERT exemplar)</p> <p>a. earthing</p> <p>b. using fuse wire</p> <p>c. use of electric meter</p> <p>d. use of stabilizer</p>	1
4	<p>An alpha particle is diverted towards west and is deflected towards north by a field. The field is magnetic. What will be the direction of the field?</p> <p>a. Towards south</p> <p>b. towards east</p> <p>c. downward</p> <p>d. upward</p>	1
5	<p>In a domestic circuit, if 8 A current is passing through it, which fuse wire having the following current limit will be used?</p> <p>a. 8 A</p> <p>b. 3 A</p> <p>c. 5 A</p> <p>d. 10A</p>	1
6	<p>No force acts on a current carrying conductor when it is placed-</p> <p>a. perpendicular to the magnetic field</p>	1

	<ul style="list-style-type: none"> b. parallel to the magnetic field c. far away from the magnetic field d. inside a magnetic field 	
7	<p>Assertion(A): Magnetic field lines never intersect each other</p> <p>Reason (R): Magnetic field lines are closed and curved lines.</p>	1
8	<p>Assertion (A): A stationary charged particle placed in a magnetic field experiences a force.</p> <p>Reason (R): A stationary charged particle does not produce a magnetic field.</p>	1
SECTION B		
9	Justify the following statement” Magnetic field lines never intersect each other”	2
10	A bird sitting on electric wire does not get electric shock but if a human touch, he or she get lethal shock. Interpret the given statement and give reason.	2
11	Suma’s mother is using an electric oven of 2kW power rating is operated in a domestic electric circuit(220V) that has a current rating of 5 A. what result do you expect? Explain.	2
12	Draw magnetic field around a bar magnet and List the two properties of magnetic field.	2
13	Design an experiment to mark magnetic field lines around the bar magnet.	2
SECTION C		
14	<ul style="list-style-type: none"> a. Draw magnetic field lines across a current carrying solenoid. b. What changes will be there if polarity of the battery is changed? Explain. 	3
15	<p>State whether an alpha particle will experience any force in a magnetic field if (alpha particles are positively charged particles)</p> <ul style="list-style-type: none"> a. it is placed in the field at rest. b. it moves in the magnetic field parallel to field lines. c. it moves in the magnetic field perpendicular to field lines. <p>Justify your answer in each case.</p>	3
16	<p>A compass needle is placed near a current carrying straight conductor. State your observation for the following cases and give reasons for the same in each case.</p> <p>(a) Magnitude of electric current is increased.</p> <p>(b) The compass needle is displaced away from the conductor</p>	3
SECTION D		
17	<p>A current carrying conductor is placed in a magnetic field. Now answer the following.</p> <ul style="list-style-type: none"> a. List the factors on which the magnitude of force experienced by conductor depends. b. When is the magnitude of this force maximum? c. State the rule which helps, in finding the direction of motion of conductor. 	5

- d. If initially this force was acting from right to left, how will the direction of force change if:
- direction of magnetic field is reversed?
 - direction of current is reversed?

18

An experiment was conducted by Aakash in his physics laboratory with his friend given below. They become curious to see the results and tried to explained with scientific principle. Answer the following in connection to the experiment:

5

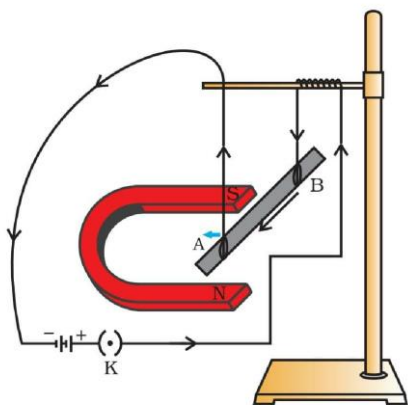

- State the principle behind the experiment
- If current of 5 A is flowing, the rod moves by 10 degrees, what will be your observation if current is increased by 10 A?
- If the orientation of the battery is changed will the rod moves toward or away from the magnet?
- State the law which help you to find the direction of the moving rod.

SECTION E

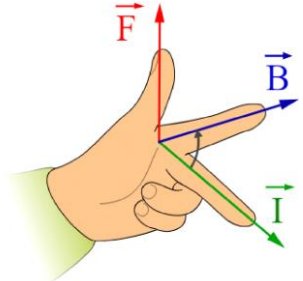
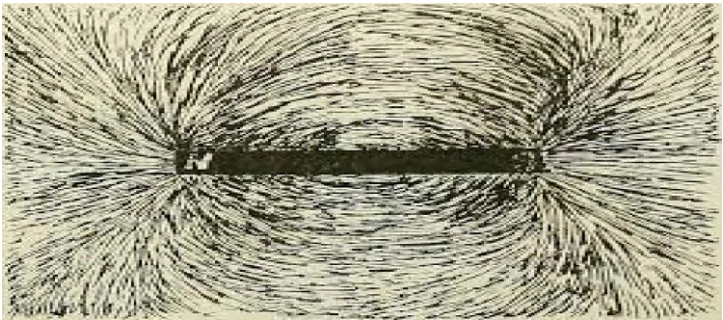
19	<p>An electric current flowing through a conductor produces a magnetic field. The field so produced exerts a force on a magnet placed in the vicinity of the conductor. French scientist Andre Marie Ampere (1775–1836) suggested that the magnet must also exert an equal and opposite force on the current-carrying conductor. The direction of forces due to a magnetic field acting on a current-carrying conductor is explained by Fleming left hand rule.</p>  <p>CC BY-SA 4.0 DEE Attribution-Share Alike 4.0 International</p>	4
	a) Suggest any one situation in which a charged particle will experience zero force in the magnetic field?	1
	b) A uniform magnetic field exists in the plane of paper pointing from left to right as shown in figure, if a proton and electron are introduced in the south direction in it, what will you observe? Give reason for your answer	2
	c) In which angle the maximum force will be experienced by a current carrying conductor placed in a magnetic field?	1
20	<p>Magnetic field lines are imaginary lines around the magnet. The direction of the magnetic field is taken to be the direction in which a north pole of the compass needle moves inside it. Therefore, it is taken by convention that the field lines emerge from north pole and merge at the south pole Inside the magnet, the direction of field lines is from its south pole to its north pole. Thus, the magnetic field lines are closed curves. The relative strength of the magnetic field is shown by the degree of closeness of the field lines. The field is stronger, that is, the force acting on the pole of another magnet placed is greater where the field lines are crowded. No two field-lines are found to cross each other. If they did, it would mean that at the point of intersection, the compass needle would point towards two directions, which is not possible</p> 	4
	a) List any two features of the magnetic field inside the bar magnet	2

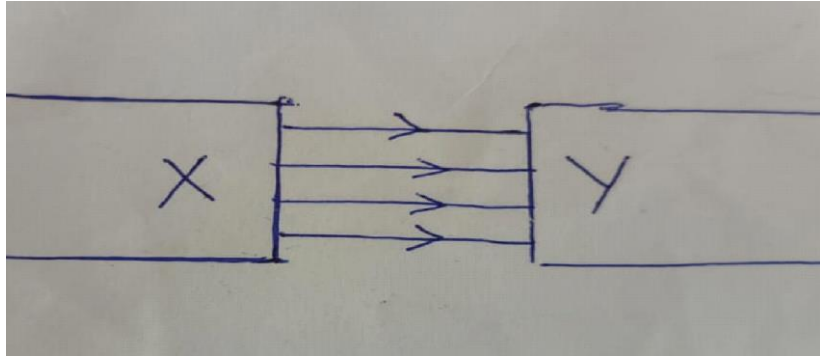
	b) In which region of the magnet will have strongest magnetic field?	1
	c) Identify the pole of the magnet X and Y in the given below diagram 	1

ANSWER KEY CHAPTER- 12 MAGNETIC EFFECT OF CURRENT

Q NO	SECTION A	MAR KS
1	d	1
2	c	1
3	a	1
4	d	1
5	d	1
6	b	1
7	b	1
8	d	1
	SECTION B	
9	The magnetic field lines never intersect each other because if two or more lines intersect each other than it means that at that point of intersection, the magnetic field has two directions at the same point. This is not possible for a magnetic field to point in more than one direction at the same point	2
10	Birds sitting on a wire don't touch the ground (or anything in contact with the ground), so there is no potential difference. But, if a bird touches a power line and equipment or other metal that is grounded, it gives electricity a path to the ground, and the bird could be shocked whereas the	2

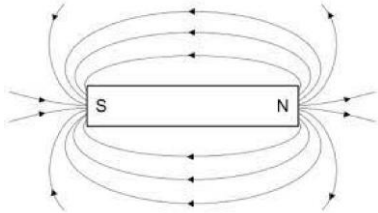
	human body is in contact with earth and thus completes the circuit for the flow of current.	
11	$P=VI$ $I=P/V$ $I=2000/220=9.09\text{ A}$ The current drawn by the electric oven is 9.09 A, which exceeds the safe limit of the circuit. Fuse element of the electric fuse will melt and break the circuit.	2
12	 <p>Following are the properties of magnetic field lines:</p> <ul style="list-style-type: none"> • They form curved and closed loops. • They never intersect each other. • The magnetic field lines are crowded near the pole where the field is strong and spread apart from each other where the field is weak. • Direction of magnetic field is from north to south outside the magnet and south to north inside the magnet. 	2 (any two points)
13	Procedure: Fix a sheet of white paper on a drawing board using some adhesive material. Place a bar magnet in the centre of it. Sprinkle some iron filings uniformly around the bar magnet. Now tap the board gently. Observe the pattern in which the iron filings arrange themselves.	2
SECTION C		
14	a) Refer NCERT fig 13.10 page no 229 b) As per right hand thumb rule, If the polarity of the battery is changed the polarity of the poles in solenoid will be reversed.	2+1
15	a) No, alpha particle will not experience any force if it is at rest, because only moving charge particle can experience force when placed in a magnetic field. b) No, alpha particle will not experience any force if it moves in the magnetic field parallel to field lines because charge particle experiences force only when it moves at an angle other than 0° with magnetic field.	1+1+1

	c) Alpha particles will experience a force in the direction perpendicular to the direction of magnetic field and direction of motion of alpha particle.	
16	<p>a) As the amount of magnetic field strength is directly proportional to the amount of current, so the deflection of compass needle increases.</p> <p>b) Since magnetic field strength at a point is inversely proportional to the distance from the wire. Hence deflection of compass decreases when it is displaced away from the conductor.</p>	1.5+1.5
SECTION D		
17	<p>a) When a current carrying wire is placed in a magnetic field, it experiences a magnetic force that depends on</p> <p>(i) current flowing in the conductor (ii) strength of magnetic field (iii) length of the conductor (iv) angle between the element of length and the magnetic field.</p> <p>b) Force experienced by a current carrying conductor placed in a magnetic field is largest when the direction of current is perpendicular to the direction of magnetic field.</p> <p>c) The rule used in finding the direction of motion of the conductor placed in a magnetic field is Flemings left hand rule. Fleming's left-hand rule is as follows: Stretch out the thumb, the forefinger, and the second (middle) finger of the left hand so that these are at right angles to each other. If the forefinger gives the direction of the magnetic field (N to S), the second (middle) finger the direction of current then the thumb gives the direction of the force acting on the conductor.</p> <p>d) (i) Direction of force will be reversed when direction of magnetic field is reversed, i.e., now force on conductor will act from left to right.</p> <p>(ii) Direction of force will be reversed, if the direction of current is reversed, i.e., the force on the conductor will act from left to right.</p>	1+1+1+2
18	<p>a) when a current carrying conductor is placed in a magnetic field, it experiences a force.</p> <p>b) if current is increased by 20 A the degree of deflection will be also doubled</p> <p>c) if the polarity of the battery is changed, the conducting wire will be moved away from the magnet.</p> <p>d) Fleming left hand rule(statement)</p>	5

SECTION E		
19	a) (i) charge is stationary (ii) if charge moves parallel to magnetic field	1/2+1/ 2
	b) As per Fleming left hand rule Proton moves in inward direction Electron moves outward direction	1+1
	c) When charge moves in perpendicular to the magnetic field	1
20	a) i) magnetic field inside the magnet is from south to north ii) magnetic field lines are parallel and equidistant.	1+1
	b) At both poles of the magnet	1
	c) X- north Y-south	1

CHAPTER- 13 OUR ENVIORNMENT

Q NO	SECTION A	MARKS
1	<p>The decomposers in an ecosystem</p> <p>(a) convert inorganic material, to simpler forms</p> <p>(b) convert organic material to inorganic forms</p> <p>(c) convert inorganic materials into organic compounds</p> <p>(d) do not breakdown organic compounds</p>	1
2	<p>What will happen if deer are missing in the food chain given below?</p> <p>Grass → Deer → Tiger</p> <p>(a) The population of tiger increases</p> <p>(b) The population of grass decreases</p> <p>(c) Tiger will start eating grass</p> <p>(d) The population of tiger decreases and the population of grass increases</p>	1
3	<p>In the following groups of materials, which group (s) contains only non-biodegradable items?</p> <p>(i) Wood, paper, leather</p> <p>(ii) Polythene, detergent, PVC</p> <p>(iii) (iii) Plastic, detergent, grass</p> <p>(iv) (iv) Plastic, Bakelite, DDT</p> <p>(a) (iii)</p> <p>(b) (iv)</p> <p>(c) (i) and (iii)</p> <p>(d) (ii) and (iv)</p>	1
4	<p>In the given food chain if the amount of energy at the fourth trophic level is 4 kJ, what</p> <p>What will be the energy available at the producer level?</p> <p>Grass → Grasshopper → Frog → Snake</p> <p>(a) 4 kJ</p> <p>(b) 40 kJ</p>	1

- (c) 400 kJ
- (d) 4000 kJ

5

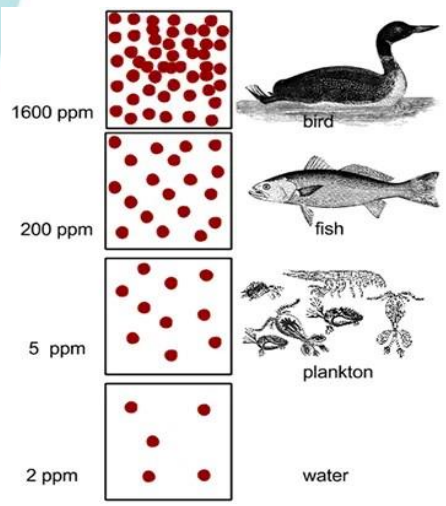

source; <https://biologyjunction.com/biological-magnification/>

Observe the picture given above and identify the phenomena given above.

- (a) trophic levels
- (b) Biomagnification
- (c) Biodegradation
- (d) Destruction of plankton

1

6

Which of the following is not a method of sustainable use of resources?

- A) Recycling
- B) Reusing
- C) Reducing
- D) Mining

1

Q. no 7 to 8 are Assertion - Reasoning based questions.

These consist of two statements – Assertion (A) and Reason (R). Answer these questions selecting

the appropriate option given below:

- (a) Both A and R are true and R is the correct explanation of A .
- (b) Both A and R are true and R is not the correct explanation of A.

	(c) A is true but R is false. (d) A is False but R is true.	
7	Assertion: Aquarium needs regular cleaning Reason: There are no microbes to clean water in aquarium, therefore, it needs to be regularly cleaned.	1
8	Assertion: The concentration of harmful chemicals is least in human beings. Reason: Man is at the apex of food chain	1
	SECTION B	
9	Suggest one word for each of the following statements/ definitions (a) The physical and biological world where we live in (b) Each level of food chain where transfer of energy takes place (c) The physical factors like temperature, rainfall, wind and soil of an ecosystem (d) Organisms which depend on the producers either directly or indirectly for food	2
10	All the decomposers are removed from earth all of a sudden. Analyse this situation and infer the consequences of this condition.	2
11	In the following food chain, plants provide 500 J of energy to rats. How much energy will be available to hawks from snakes? Explain and identify the law involved. Plants → Rats → Snakes → Hawks	2
12	Biodegradable wastes are accumulating in Ratan's village. Suggest any two consequences of this condition in that village.	2
13	As part of Eco club activities, members of Eco club made cloth bags and were sold among the school students and they were motivated to use these bags for shopping and other activities. Analyse this situation and explain the ways in which it helps to protect our environment.	2
	SECTION C	
14	Skin cancer becomes more common in certain parts of the United States of America due to the depletion of a protective layer of gas X. (a) Identify this gas X and which layer of atmosphere we can see this gas X. (b) Explain the process behind the formation of gas X . (c) Identify the causative agent behind the depletion of gas X	3
15	Select the biodegradable items from the list given below- Polythene bags, cotton clothes, wilted flowers, pencil shavings, glass bangles, bronze statue, vegetable peels iron nails, jute bag and dried leaves	3

16	(a) Why is damage of ozone layer a cause of concern? (b) What step is being taken to limit this damage?	3
----	--	---

SECTION D

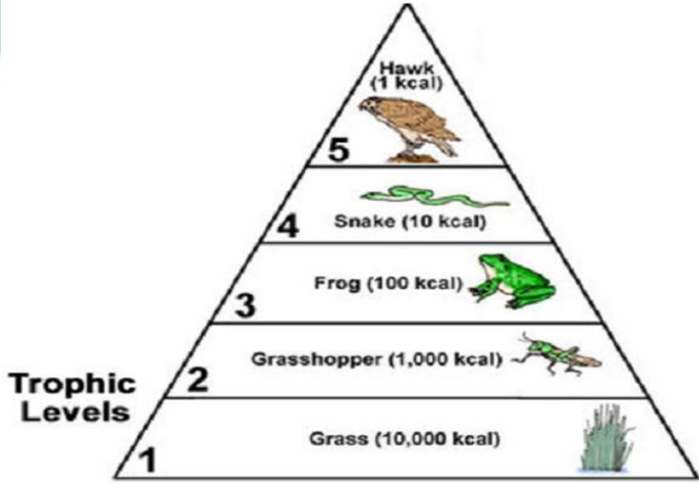
17	 <p>(a) Observe the diagram given above and find out how much percentage of energy flows from sun to producers?</p> <p>(b) By using the above-mentioned percentage calculate the amount of solar energy to which the grass / producers are exposed.</p> <p>(c) Analyse and find out the law which is applicable to the transfer of energy from second trophic level to the third trophic level and explain the law.</p>	5
----	--	---

18	(a) Some substances in our ecosystem are biodegradable and some are non-biodegradable. Give reasons. (b) Give any two ways in which non-biodegradable substances would affect the environment. (c) Name two different methods for the disposal of biodegradable wastes.	5
----	---	---

SECTION E

19	Minamata disease is methylmercury poisoning that leads to neurological symptoms. This condition develops after a person has been eating heavily contaminated seafood daily.	4
----	---	---



Source :

https://content.time.com/time/specials/packages/article/0,28804,1986457_1986501_1986450,00.html

The first record of Minamata disease was in Japan in the 1950s. At the time, people ate fish that had been contaminated by large quantities of mercury compounds that were discharged into Minamata Bay by a chemical factory. In July 1959, researchers from Kumamoto University discovered the source of the illness—high levels of mercury poisoning. They named the condition Minamata disease. It was caused by dumping the factory wastes containing mercury into the lake. This mercury enters the food chain and reaches the top most trophic level.

(source : <https://www.verywellhealth.com/minamata-disease-2860856>)

- (a) Identify and write the name of the biological process that is responsible for the Minamata disease and explain about this biological process.
- (b) Name the organisms that occupied the highest trophic level in case of the Minamata tragedy.
- (c) Name the element which was responsible for this disease.

2

1

1

20

Food chain is a sequence of organisms where nutrients and energy are transferred from one organism to the other. Each step or level of the food chain forms a trophic level. A food chain only follows just one path as animals finds food. A hawk eats a snake, which has eaten a frog, which has eaten a grasshopper, which has eaten grass. A food web on the other hand shows the many different pathways by which plants and animals are connected. As an example, a hawk might also eat a mouse, a squirrel, a frog or some other animal. The snake may eat a beetle, a caterpillar, or some other animal.

4

	<p>(a) what is the reason that trophic level 1 has the highest biomass.</p> <p>(b) If all the living entities of a particular trophic level are eliminated, what impact would it create on other trophic levels. (the trophic level above and below)</p> <p>(c) Which trophic level has the ability to harness energy from the sun and prepare organic substances?</p>	
--	--	--

ANSWER KEY

CHAPTER 13 OUR ENVIRONMENT

Q NO	SECTION A	MARKS
1	(b) convert organic material to inorganic forms	1
2	(d) The population of tiger decreases and the population of grass increases	1
3	(d) (ii) and (iv)	1
4	d) 4000 kJ	1
5	(b) Biomagnification	1
6	d) Mining	1
7	(a) Both A and R are true and R is the correct explanation of A	1
8	(d) A is False but R is true .	1
	SECTION B	
9	(a) Ecosystem (b) Trophic level (c) Abiotic factors (d) Heterotrophs	2
10	Decomposers are the organism which break down the dead bodies and the organic matter back into the soil. Absence of decomposers in an ecosystem leads to the following consequences.	2

	<p>(a) In the absence of decomposers, the dead bodies of animals will accumulate in the ecosystem.</p> <p>(b) In the absence of decomposers, all the nutrient cycle will come to an end and as a result the soil will be deprived of nutrients.</p>	
11	<p>In an ecosystem, only 10% of energy is transferred from one trophic level to next, i.e. 10 percent law and rest is dissipated into the environment. Therefore, if plants (being producers-1st trophic level)-transfer 500 J of energy to rats (2nd trophic level) then rats would transfer 50 J of energy to snakes (3rd trophic level) which in turn will transfer only 5 J of energy to hawks (4th or last trophic level) in a food chain.</p>	2
12	<p>The harmful effects of the accumulation of biodegradable wastes without proper disposal are the following.</p> <p>(a) Accumulated biodegradable wastes act as breeding ground for cockroaches, flies, rats etc. which can lead to the spread of many infectious diseases.</p> <p>(b) The decomposition of accumulated biodegradable wastes, contaminate the surface water as well as underground water.</p> <p>(c) The decomposition of biodegradable substances, lead to the production of methane gas, which accelerates the process of global warming.</p> <p>(Any two points)</p>	2
13	<p>The advantages of using cloth bags are the following.</p> <p>(a) Cloth bags can be used again and again.</p> <p>(b) Since cloth bags coming under biodegradable substances, they can be easily decomposed and can be returned to the soil.</p>	2
SECTION C		
14	<p>(a) Gas X is ozone and it is found in stratosphere</p> <p>(b) In the upper layers of the atmosphere oxygen molecules are acted upon by ultraviolet rays, which break down molecular Oxygen into atomic Oxygen. This atomic Oxygen mixes with O₂ molecule to form O₃ (or the 2 equations involved)</p>	3

	<ol style="list-style-type: none"> 1. These inert substances simply persist in the environment. This means that these substances require land area for dumping. 2. Excess of fertilizers, pesticides and other chemicals changes soil chemistry and also affects aquatic life. 3. Most of these chemicals and heavy metal are easily absorbed by the organisms. This causes biological magnification. (any two) <p>(c) By making biogas plants Pit composting Converting into manures Vermicomposting (Any two)</p>	2
	SECTION E	
19	<p>(a) Biological magnification Explanation</p> <p>Unknowingly some harmful chemicals enter our bodies through the food chain like pesticides and other chemicals to protect our crops from diseases and pests. These chemicals are either washed down into the soil or into the water bodies. From the soil, these are absorbed by the plants along with water and minerals and from the water bodies, these are taken by the aquatic plants and animals. As these chemicals are not degradable, these get accumulated progressively at each trophic level. As human beings occupy the top level in any food chain, the maximum concentration of these chemicals get accumulated in our bodies. This phenomenon is known as biological magnification.</p> <p>(b) Human beings (c) Mercury</p>	2
20	<p>(a) Producers or first trophic levels are directly exposed to sunlight and thus they can able to convert maximum solar energy into biomass, compared to any other trophic levels. Because of this reason trophic level 1 has the highest biomass.</p> <p>(b) The trophic level above will not get sufficient food and can lead to decrease in its population size.</p> <p style="padding-left: 40px;">The trophic level will not have potential predators and thus their population size will flourish.</p> <p>(c) First trophic level.</p>	4

CLASS – IX

COMPETENCY BASED TEST ITEMS: CHAPTERWISE

S.NO.	NAME OF THE CHAPTER	PAGE NO.
1	MATTER IN OUR SURROUNDINGS	96
2	IS MATTER IN OUR SURROUNDINGS PURE?	102
3	ATOMS AND MOLECULES	109
4	STRUCTURE OF THE ATOM	115
5	THE FUNDAMENTAL UNIT OF LIFE	121
6	TISSUES	127
7	MOTION	132
8	FORCE AND LAWS OF MOTION	137
9	GRAVITATION	144
10	WORK, POWER AND ENERGY	151
11	SOUND	158
12	IMPROVEMENT IN FOOD RESOURCES	167

CHAPTER – 1 MATTER AROUND OUR SURROUNDINGS

Q NO	SECTION A	MARKS
1	<p>While visiting a Natural Gas Compressing Unit it was found that a gas can be liquefied under specific conditions of temperature and pressure. Identify the correct set of conditions.</p> <p>a) Low temperature and high pressure (b) Low temperature and low pressure (c) High temperature and low pressure (d) High temperature and high pressure</p>	1
2	<p>Read the statement and find out the correct one</p> <p>(a) Only gases behave like fluids. (b) Gases and solids - both behave like fluids. (c) Only liquids are fluids. (d) Gases and liquids – both behave like fluids</p>	1
3	<p>A drop of ink when added to 100 ml of water, the ink particles started spreading into the water. Connect this to the property of water.</p> <p>a. Sublimation b. Vaporization c. Diffusion d. condensation</p>	1
4	<p>It was observed by the students that the level of water in an earthen pot decreased during summer season. Mention the phenomenon behind this.</p> <p>(a) Diffusion (b) Evaporation (c) Transpiration (d) Osmosis</p>	1
5	<p>It is easier to break a piece of chalk than an iron nail. Which characteristic property of a matter is it mentioning about.</p> <p>a. Particles are continuously moving b. Particles of matter attract each other. C. Inter mixing of particles of different types d. Latent heat of vaporization</p>	1
6	<p>Units of temperature</p> <p>a. Bar and pascal b. Milligram and kilogram c. Degree Celsius and kelvin d. Gram per centimetre cube and kilogram per metre cube</p>	1
7	<p>Directions: In each of the following questions, a statement of Assertion is given, and a corresponding statement of Reason is given just below it. Of the statements, given below, mark the correct answer as:</p> <p>(a) Both assertion and reason are true, and reason is the correct</p>	1

	<p>explanation of assertion. (b) Both assertion and reason are true, but reason is not the correct explanation of assertion. (c) Assertion is true, but reason is false. (d) Assertion is false, but reason is true</p> <p>Assertion: Disinfectants are rubbed on our hands before taking injections and it feels cold. Reason: Particles of disinfectant gains energy from the surroundings and evaporates and leaves our hands cold.</p>	
8	<p>Assertion: Steam is more dangerous than boiled water Reason: Solid particles have higher melting point than water.</p>	1
SECTION B		
9	<p>Read the following situations and categorise them into diffusion / osmosis</p> <ol style="list-style-type: none"> Smell of biriyani while passing through a restaurant. Spread of corona virus Swelling of Chana when soaked in water Earth worm dying when salt is sprinkled over them. 	2
10	<p>Camphor is a substance that we use for lighting lamp. a. List the state of camphor before and after burning. b.) Elaborate the process</p>	2
11	<div style="text-align: center;">  </div> <p>Reemu was making steam cake. Suddenly she felt intense heat from the puff of steam gushing out of the vessel. She wondered whether the temperature of the steam was higher than that of the water boiling in the kettle. Comment.</p>	2
12	<p>a. Boiling point of Alcohol is 78 degrees Celsius. Convert it into Kelvin scale. b. Also mention the physical state of water at 100 degree Celsius.</p>	2
13	<p>Dried raisins were put in water, and it was observed after some time that it swells. Mention the phenomenon and Explain.</p>	2
SECTION C		
14	<p>The temperature of a substance remains constant during its melting point or boiling point. Explain the reason behind it.</p>	3

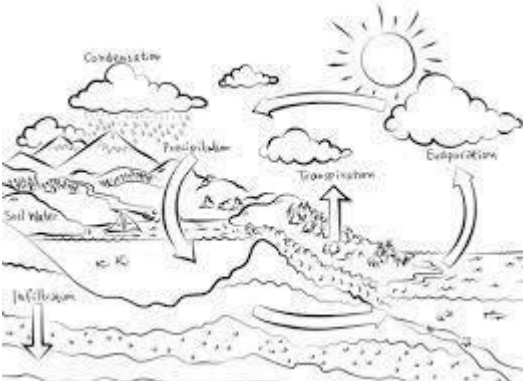
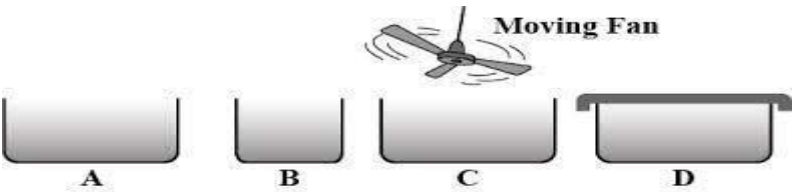
15	<p>a. Rita made lemon juice and added some ice cubes into it. She observed that ice floated in the juice. Give the reason for this.</p> <p>b. Plants use carbon dioxide for photosynthesis. Mention its natural state. How is it different from dry ice.?</p>	3
16	 <p>Interconversion of state of matter is a natural phenomenon. Observe the picture and explain the conversion of matter taking place. Mention about the energy transfer also.</p>	3
SECTION D		
17	<p>Observe the picture given below and suggest which of the vessels A, B, C or D will have the highest rate of evaporation? Explain with reference to each vessel.</p> 	5
18	Matter exists in three states. Compare and write the properties of different states of matter.	5
SECTION E		
19	<p>Evaporation causes natural cooling. The basic concept is that in order for matter to change state, it must either receive or lose energy. When molecules of matter change from liquid to gas, they require energy to overcome their potential energy through kinetic energy. As a result, the liquid absorbs energy from its surroundings.</p> <p>a. Clothes dry faster on a winter day than on a rainy day. Why?</p>	4

	<p>b. It is easy to drink hot tea from a saucer faster than from a cup. Why?</p> <p>c. Evaporation requires energy. Explain.</p>	
20	<p>In an experimental activity, crushed ice was taken in a beaker. A thermometer is fitted in such a way that its bulb was thoroughly surrounded by ice. The beaker is now slowly heated and the temperature was regularly noted. The temperature rises gradually as the heating is continued and becomes constant when the ice starts changing into liquid.</p> <p>a. Where does the heat energy go when the temperature does not rise?</p> <p>b. Name the process explained here.</p> <p>c. Differentiate melting and boiling point.</p>	4

ANSWER KEY CHAPTER -1 MATTER AROUND OUR SURROUNDINGS

Q N O	SECTION A	MARKS
1	a.	1
2	d.	1
3	c.	1
4	b	1
5	b.	1
6	c	1
7	a.	1
8	c.	1
	SECTION B	
9	<p>a. Diffusion</p> <p>b. Diffusion</p> <p>c. Osmosis</p> <p>d. osmosis</p>	½ each
10	<p>a. Solid to gas</p> <p>b. The change of state from solid to gas without changing to liquid state is called Sublimation.</p>	1 1
11	The temperature of steam is not different from that of boiling water. The temperature of boiling water as well as that of steam is 100 °C, but steam has more energy because of the latent heat of vaporization.	2
12	a. $78+273=351$ degree Celsius.	1 1

	b. At 100-degree Celsius, water exists in both the liquid state as well as in gaseous state.	
13	<p>Osmosis</p> <p>Solution outside the raisin has a higher concentration of water molecules. Therefore, water from outside enters the raisin through the process of osmosis and hence the raisin swells up when kept in water. The outer membrane of the cells of the raisin acts as a semi-permeable membrane.</p>	$\frac{1}{2}$ 1 1/2
	SECTION C	
14	<p>Ans: The temperature of a substance remains constant at its melting and boiling points until all the substance melts or boils. The heat supplied is continuously used up in overcoming the forces of attraction between the particles of the substance during the transition of physical state of the substance. This is known as the latent heat of fusion or the latent heat of vaporization, as per the situation. Thus, heat energy is absorbed by the substance without showing any rise in temperature.</p>	$\frac{1}{2}$ 2 1/2
15	<p>a. Ice is the solid state of water. It has a greater amount of space between its molecules compared to water molecules. As a result, the volume of ice is larger than that of water, leading to a lower density of ice. This is the reason why ice tends to float on water, as water has a higher density than ice.</p> <p>b. Carbon dioxide is seen in gaseous state. When carbon dioxide is stored in high pressure it becomes solid without coming into liquid state. This dry ice.</p>	1 1/2 $\frac{1}{2}$ 1
16	<p>Evaporation – Change of water from liquid state to gaseous state</p> <p>Condensation Change of gaseous state to liquid state of water.</p> <p>s During evaporation heat is absorbed from the surrounding During Condensation heat is released into the surrounding.</p>	$\frac{1}{2}$ each
	SECTION D	
17	<p>Vessel (c) will have the highest rate of evaporation. Evaporation is a surface phenomenon; the rate of evaporation increases with an increase in surface area. The moving fan will reduce humidity and increase the rate of evaporation. The particles of water vapours will move away with wind (moving air) with an increase in air speed.</p> <p>Surface area in vessel (b) is lesser than that in vessel (a) and vessel (c) whereas vessel (d) is completely closed and offers no surface area for evaporation.</p>	3 2

18

5

Solids	Liquids	Gases
Highly Strong intermolecular forces between the molecules, leads to a definite volume in Solids.	The intermolecular forces are stronger than gases but weaker than solids.	The intermolecular forces are weaker than solids. Thus, there is no definite volume in Gases.
Solids have a definite shape to them.	Liquids do not have a definite shape.	Gases do not have a definite shape.
The intermolecular space between solids is absent.	The intermolecular space is moderate but present.	The intermolecular space is large.
The force of attraction between the molecules is incredibly high.	The force of attraction between molecules is pretty moderate.	There is no intermolecular force between the molecules.
They are incompressible.	Liquids cannot be compressed.	Gases can be compressed.
Solids have a definite shape and volume.	Liquids have a definite volume.	Gases have no definite volume.

SECTION E

19

- a.** In winters though the sun is not very hot but the air is dry i.e it does not contain much moisture so evaporation of water takes place faster than rainy season where the air is fully moist.
- b.** The rate of evaporation increases as the surface area of the liquid increases.
- c.** Evaporation requires energy because it occurs when intermolecular bonds between liquid molecules break, and to break those bonds some amount of energy is required. This required energy is provided by the surrounding environment, hence it causes a cooling effect.

1

1

2

20

- a. It is utilized for bringing out the complete change of state
- b. Latent heat of fusion
- c. Melting point is the temperature at which a solid becomes a liquid at normal atmospheric pressure. Boiling point is the Temperature at which a liquid starts boiling at atmospheric pressure

1

1

2

CHAPTER – 2 IS MATTER AROUND US PURE?

Q NO	SECTION A	MARKS
1	Brass is a (a) Compound (b) Elements (c) Homogeneous mixture (d) Heterogenous mixture	1
2	Which of the following statements is true for pure substances? (i) Pure substances contain only one kind of particles (ii) Pure substances may be compounds or mixtures (iii) Pure substances have the same composition throughout (iv) Pure substances can be exemplified by all elements other than nickel (a) (i) and (ii) (b) (i) and (iii) (c) (iii) and (iv) (d) (ii) and (iii)	1
3	What is the statement? “10 percent common salt in water by mass” signifies. (a) 10 grams of common salt dissolved in 100 grams of water. (b) 10 grams of common salt dissolved in 90 grams of water. (c) 20 grams of common salt dissolved in 200 grams of water. (d) 20 grams of common salt dissolved in 90 grams of water.	1
4	Solid solution in which the solute is gas ——— (a) Copper dissolved in gold (b) Camphor in nitrogen gas (c) Solution of hydrogen in palladium (d) All of the above	1
5	In tincture of iodine, identify the solute and solvent? (a) alcohol is the solute and iodine is the solvent (b) iodine is the solute and alcohol is the solvent	1

	(c) any component can be considered as solute or solvent. (d) tincture of iodine is not a solution									
6	Two substances, A and B, were made to react to form a third substance, A_2B , according to the following reaction $2A + B \rightarrow A_2B$. Which of the following statements concerning this reaction are incorrect? (i) The product A_2B shows the properties of substances A and B (ii) The product will always have a fixed composition (iii) The product so formed cannot be classified as a compound (iv) The product so formed is an element (a) (i), (ii) and (iii), (b) (ii), (iii) and (iv) (c) (i), (iii) and (iv) (d) (ii), (iii) and (iv)	1								
7	Directions: In question no. 7 and 8, a statement of assertion (A) is followed by a statement of reason (R). Mark the correct choice as: (a) Both assertion (A) and reason (R) are true and reason (R) is the correct explanation of assertion (A). (b) Both assertion (A) and reason (R) are true but reason (R) is not the correct explanation of assertion (A). (c) Assertion (A) is true but reason (R) is false. (d) Assertion (A) is false but reason (R) is true. 7. Assertion : When a beam of light is passed through a colloidal solution placed in a dark place the path of the beam becomes visible. Reason : Light gets scattered by the colloidal particles.	1								
8	Assertion : Fog is an example of aerosol. Reason : The dispersion medium is gas and dispersed phase is liquid in fog.	1								
	SECTION B									
9	1. Classify the substances given in the column into elements and compounds. <table border="1" style="margin-left: auto; margin-right: auto;"> <tr> <td>copper</td> <td>water</td> <td>Calcium carbonate</td> <td>iron</td> </tr> <tr> <td>mercury</td> <td>zinc</td> <td>Sodium chloride</td> <td>diamond</td> </tr> </table>	copper	water	Calcium carbonate	iron	mercury	zinc	Sodium chloride	diamond	2
copper	water	Calcium carbonate	iron							
mercury	zinc	Sodium chloride	diamond							

10	<p>1. Class 9 B students were asked to prepare a 10% (Mass/Mass) solution of sugar in water. Sita dissolved 10 g of sugar in 100 g of water while Neeta prepared it by dissolving 10 g of sugar in water to make 100 g of the solution.</p> <p>(a) Are the two solutions of the same concentration? (b) Compare the mass % of the two solutions.</p>	2
11	Calculate the mass of sodium sulphate required to prepare its 20% (mass percent) solution in 100 g of water?	2
12	It is not possible to distinguish particles of a solute from the solvent in solution. Give reason?	2
13	Explain why particles of a colloidal solution do not settle down when left undisturbed, while in the case of a suspension they do. {NCERT Exemplar}.	2
SECTION C		
14	<p>Sonu and his friends took an old shoe box and covered it with a black paper from all sides. They fixed a torch at one end of the box by making a hole in it and made another hole on the other side to view the light. They placed a glass of milk in the box. They were amazed to see that milk taken in the tumbler was illuminated. They tried the same activity by taking a salt solution but found that light simply passed through it.</p> <p>(a) Explain why the milk was illuminated. Name the phenomenon involved.</p> <p>(e) Same results were not observed with a salt solution. Explain. (f) suggest two more solutions which would show the same effect as shown by the milk solution?</p>	3
15	An element is sonorous and highly ductile. Under which category would you classify this element? Write any two other characteristics you expect the element to possess?	3
16	<p>Non-metals are usually poor conductors of heat and electricity. They are non-lustrous, non-sonorous, non-malleable and are coloured.</p> <p>(a) Name a lustrous non-metal. (b) Name a non-metal which exists as a liquid at room temperature. (c) Name a non-metal which is required for combustion.</p>	3
SECTION D		

17	<p>a) Differentiate between a true solution and a colloid.</p> <p>b) Distinguish between compounds and mixtures.</p>	5
18	<p>(a) Under which category of mixtures will you classify alloys and why?</p> <p>(b) A solution is always a liquid. Comment.</p> <p>(c) Can a solution be heterogeneous? [NCERT Exemplar]</p>	5
SECTION E		
19	<p><u>Read the given information and answer the following questions: (1 x 4 = 4 M)</u></p>  <p><u>CASE-</u> Milk is actually a mixture of water, fat, proteins etc. When a scientist says that something is pure, it means that all the constituent particles of that substance are the same in their chemical nature. A pure substance consists of a single type of particle. The elements and compounds comes under the pure substances. As we look around, we can see that most of the matter around us exists as mixtures of two or more pure components, for example, sea water, minerals, soil etc. are all mixtures.</p> <p>Depending upon the nature of the components that form a mixture, we can have different types of mixtures; homogeneous and heterogeneous mixture.</p> <p>Q1. How will you describe a pure substance?</p> <p>Q2. Give two examples of a compound?</p> <p>Q3. Air is a homogeneous mixture. justify the statement</p>	4
20		4



CC BY-SA 4.0 DEED Attribution-ShareAlike 4.0 International

A true solution is a homogeneous mixture of two or more substances. It consists of solute and solvent. The particle size of the true solution is less than 1 nanometer. A suspension is a heterogeneous mixture in which the solute particle does not dissolve but remains suspended throughout the bulk of the medium. A colloid is a mixture that is actually heterogeneous but appears to be homogeneous as the particles are uniformly spread throughout the solution.

- 1) Identify the components of a solution?
- 2) Differentiate a colloid from a suspension?
- 3) Name the phenomenon shown by colloids and find an example as you have seen it in nature?

ANSWER KEY CHAPTER- 2 IS MATTER AROUND US PURE?

Q NO	Section A	MARKS
1	c	1
2	b	1
3	b	1
4	c	1
5	b	1
6	c	1
7	a	1
8	a.	1
SECTION B		
9	Elements – Copper, iron, mercury, zinc, diamond Compounds – Calcium carbonate, sodium chloride, water	2

10	<p>(a) No, Neeta has higher mass percentage.</p> <p>b) solution made by sita= Mass % = $10/(10+100) \times 100$ $=10/110 \times 100 = 9.09\%$ Solution made by Neeta = Mass% = $10/100 \times 100 = 10\%$</p>	2
11	<p>Let the mass of sodium sulphate required be = x g The mass of solution would be = (x + 100) g x g of solute in (x + 100) g of solution</p> $20\% = \frac{x}{x+100} \times 100$ $20x + 2000 = 100x$ $80x = 2000$ $x = \frac{2000}{80} = 25 \text{ g}$	2
12	<p>A true solution is homogeneous in nature. The solute and solvent particles are very small. They cannot be distinguished even under a microscope.</p>	2
13	<p>Particle size in a suspension is larger than those in a colloidal solution. Also molecular interaction in a suspension is not strong enough to keep the particles suspended and hence they settle down.</p>	2
SECTION C		
14	<p>(a) Milk is a colloid. If a beam of light is put on a milk sample contained in a beaker, the path of the light beam is illuminated and becomes visible when seen from the other side. This is because the colloidal particles are big enough to scatter light falling on them. This scattered light enters our eyes and we are able to see the path of the light beam. The scattering of light by colloidal particles is known as the Tyndall effect.</p> <p>(b) Salt solution is a true solution. If a beam of light is put on a salt solution kept in a beaker in a dark room, the path of the light beam is not visible inside the solution when seen from the other side. This is because salt particles present in it are so small that they cannot scatter light rays falling on them.</p> <p>(c) Detergent solution, sulphur solution.</p>	3
15	<p>A metal is sonorous and ductile. Thus if an element possesses these qualities, we will keep this under the category of metals.</p>	3

	<p>other characteristics of metals are:</p> <ul style="list-style-type: none"> • Metals are highly malleable. (any two) • Metals have a high melting and boiling point. • Metals are lustrous. • Metals have a high density and thus are hard. • Metals are a good conductor of heat and electricity. 	
16	<p>a) Lustrous non-metal Iodine b). Non-metal, which exists as a liquid at room temperature. Bromine c) non-metal oxygen</p>	3
SECTION D		
17	<p>a) Any two differences b) Any three differences.</p>	5
18	<p>(a) Alloys are homogeneous mixture of two or more elements because the constituent elements mix together and give a mixture which is uniform throughout. (b) No, solid solutions and gaseous solutions are also possible. Examples are brass, air. (c) No, a solution cannot be heterogeneous in nature.</p>	5
SECTION E		
19	<p>a. A pure substance consists of a single type of particles. b. Any 2 examples c. Yes. justification</p>	4(1+1+2)
20	<p>a. It consists of solute and solvent. b any one difference c Tyndall effect examples of Tyndall effect are (any 1) Sunlight entering into a dark room. Lots of dust particles suspended in a lit-up room. When the weather is foggy and smoggy, beams of headlights are clearly visible. Scattering of light by water droplets present in the air.</p>	4(1+1+2)

CHAPTER - 3

ATOMS AND MOLECULES

Q.N O	SECTION A	MARKS
1	The symbol Co represents a. Copper b. Cobalt c. Carbon d. carbon monoxide	1
2	The chemical formula of Ammonium Sulphate is a. NH_4SO_4 b. NH_4SO_2 c. $(\text{NH}_4)_2\text{SO}_4$ d. NH_2SO_4	1
3	Identify the wrong statements A. Atoms are fundamental units of life. B. All atoms have equal number of subatomic particles C. Atoms are always neutral in nature. D. A molecule may contain similar or different types of atoms E. More than two atoms only make a molecule a. A, B, C b. A, B, E c. B, C, D, E d. B, C, D	1
4	Identify triatomic molecules from the following? a. Nitrogen b. Hydrogen b. Ozone d. oxygen	1

5	<p>Mass of 1 molecule of Oxygen is</p> <p>a. 16g</p> <p>b. 8u</p> <p>c. 12x16u</p> <p>d.32u</p>	1
6	<p>Identify correct statements</p> <p>1u is the</p> <p>A. mass of one C-12 atom</p> <p>B. 1/12th of mass C-12 atom</p> <p>C. Mass of one Hydrogen molecule</p> <p>D. Mass of 1/16 of an Oxygen atom</p> <p>a. B, C, D</p> <p>b. B, C</p> <p>c. B</p> <p>d. B, D</p>	1
	<p>Question number 7 and 8 consists of two statements, namely, Assertion (A) and Reason (R).</p> <p>Select the correct answer from the following</p> <p>(a) Both Assertion (A) and Reason (R) are the true and Reason (R) is a correct explanation of Assertion (A).</p> <p>(b) Both Assertion (A) and Reason (R) are the true but Reason (R) is not a correct explanation of Assertion (A).</p> <p>(c) Assertion (A) is true and Reason (R) is false.</p> <p>(d) Assertion (A) is false and Reason (R) is true.</p>	
7	<p>A -Assertion: Valency of Aluminium is 3 and it forms Al^{3+}</p> <p>R-Reason : Metals form cations by losing electrons in order to get stability.</p>	1
8	<p>A -Assertion: phosphorous is a polyatomic molecule</p> <p>R-Reason: Atomicity of phosphorous is 8</p>	1
SECTION B		

9	List any two elements which lack combining capacity? Justify your answer stating relevant reasons	2
10	What are monoatomic ions? Give one example each for a. monoatomic cation b. monoatomic anion	2
11	Formula unit mass of the compound is 58.5u. Identify the compound with its chemical formula. Mention any one use of the compound in our daily life	2
12	Write down the chemical name of a. AlPO_4 b. ZnO c. H_2S d. CCl_4	2
13	Identify anions and cations in the following compounds a. Calcium hydroxide b. Sodium carbonate	2
SECTION C		
14	a. Mention any two-point difference between atoms and ions b. Represent following elements with their symbols Gold, Iron	3
15	8.25g of Lead nitrate reacts with 12.05g of sodium chloride. Predict the products formed and their total mass. State the law to support your answer	3
16	Write chemical formula of following compounds by crossing over valences a. Sodium hydrogen carbonate b. Calcium hydroxide c. Zinc phosphate	3
SECTION D		
17	a. List the postulates of Dalton's Atomic theory b) which postulate/postulates were disproved later? c. Mention the discovery that led to this disapproval?	5
18	a. Design an experiment to prove law of conservation of mass b. Illustrate with the help of diagram and mention any two precautions to be followed	5

SECTION E

19	<p>Atomic mass is the quantity of matter contained in an atom of an element. It is the sum of the mass of the protons, neutrons, and electrons that make up the atom.</p> <p>Carbon-12 was chosen as the reference substance because its atomic mass could be measured accurately.</p> <p>Atomic mass is expressed as a multiple of one-twelfth the mass of the carbon-12 atom i.e. $1.992646547 \times 10^{-23}$ gram, which is assigned an atomic mass of 12 units. The atomic mass unit is also called the unified mass (u)</p> <p>a) Name the international agency that approves standardized methods for measurement, atomic weights etc</p> <p>b). Define 1 unified mass(1u)</p> <p>c) Calculate molecular mass of i) HNO_3 ii) $\text{C}_6\text{H}_{12}\text{O}_6$ OR</p> <p>c). Mention the atomic mass of any four elements you are familiar with</p>	4
20	<p>In 1794, Joseph Proust, a French chemist formulated the law of constant proportions from the work he did on sulfates, metal oxides and sulfides. Also, this law was favored since Dalton's atomic theory was introduced as well. The relation between them was also discovered by Jacob Berzelius, a Swedish chemist in the year 1811.</p> <p>A) Calculate the amount of Hydrogen and oxygen obtained when 90g water is decomposed will be equal to</p> <p>b) What is the ratio by mass of Carbon and Oxygen in CO_2?</p> <p>c) State the postulates of Dalton's atomic theory that explains Proust's law?</p>	4

ANSWER KEY CHAPTER- 3 ATOMS AND MOLECULES

Q.NO	SECTION A	MAR KS
1	b. Cobalt	1
2	c. $(\text{NH}_4)_2\text{SO}_4$	1
3	b. A , B, E	1
4	b. Ozone	1
5	d.32u	1
6	d. B , D	1
7	B	1
8	C	1
SECTION B		
9	Helium, Neon Their outer most shell is filled, valency is zero	1 1
10	Monatomic ions are charged particles with only one atom in them. a. H^+ b. Cl^- (or any other eg)	1 $\frac{1}{2}+\frac{1}{2}$
11	NaCl Used in cooking/preserving	1 1
12	a. Aluminium phosphate b. Zinc oxide c. Hydrogen sulphide d. Calcium tetra chloride	$\frac{1}{2} \times 4$
13	anions cations a. Ca^{2+} OH^- b. Na^+ CO_3^{2-}	2
SECTION C		
14	Atoms -Not charged -neutral, equal number of protons and electrons, Ions -either positively or negatively charged, number of protons and electrons vary Au, Fe	2 1
15	Products are Lead chloride and sodium nitrate Total mass $8.25+12.05=20.3\text{g}$ Law of conservation of mass states that mass can neither be created nor destroyed in a chemical reaction.	1 1 1

16	Correct formula crisscrossing	1/2x3 1/2x3
SECTION D		
17	<p>a) All matter consists of indivisible particles called atoms.</p> <ul style="list-style-type: none"> • Atoms of the same element are similar in shape and mass but differ from the atoms of other elements. • Atoms cannot be created or destroyed. • Atoms of different elements may combine with each other in a fixed, simple, whole number ratio to form compound atoms. • Atoms of the same element can combine in more than one ratio to form two or more compounds. • Atoms are the smallest unit of matter that can take part in a chemical reaction. <p>(b) that atoms are indivisible and that all atoms of a given element are identical in mass and properties.</p> <p>c) discovery of electrons</p>	5
18	<p>Designing experiment with diagram mass of reactants and products precautions (correct mass, making the set up sealed or any other)</p>	5
SECTION E		
19 a.	<p>IUPAC One atomic mass unit (1u) is a mass unit equal to one-twelfth (1/12th) the mass of one atom of carbon-12 i) 63u ii) 180u (with calculation)</p>	4
c		
20	<p>a) 1:8 ratio 10g Hydrogen and 80g Oxygen b) 12u +32u 3:8 ratio c) Atoms of different elements combine in fixed ratios to form compounds a.</p>	4

CHAPTER- 4 STRUCTURE OF ATOM

Q NO	SECTION A	MARKS
1	Analyse the false statement from the following. a. Nucleons comprise of protons and neutrons b. Mass number is sum of protons and neutrons c. Atoms having the same atomic number but different mass number are Isobars of elements. d. Nuclear reactors use isotope of uranium	1
2	Alpha particles are- a. Helium atoms b. doubly charged Helium ions c. doubly charged Hydrogen atom d. None of the above	1
3	Identify the set of elements having stable octet state. a. Carbon, Nitrogen, Hydrogen b. Sodium, Magnesium, Aluminium c. Hydrogen, Helium, Lithium d. Helium, Neon, Argon	1
4	The atomic number of an element signifies- a. Valency of an element. B The number of protons in an atom of an element. c. The number of electrons in an atom of an element. d. The sum of protons and neutrons in an atom of an element.	1
5	Arrange the discoverers of electron, proton and neutron respectively a. J J Thomson, E. Goldstein and James Chadwick b. E. Goldstein and James Chadwick, J J Thomson c. James Chadwick, J J Thomson and E. Goldstein d. J J Thomson, James Chadwick and E. Goldstein	1
6	The valency of the element Phosphorus is a) 0,1 b) 3,5 c) 0,5 d) 3,0	1
7	<i>Directions:</i> In each of the following questions, a statement of Assertion is given, and a corresponding statement of Reason is given just below it. Of the statements, given below, mark the correct answer as: (a) Both assertion and reason are true, and reason is the correct explanation of assertion. (b) Both assertion and reason are true, but reason is not the correct explanation of assertion. (c) Assertion is true, but reason is false. (d) Assertion is false, but reason is true	1

16	Carbon exists in nature in different forms. Estimate the number of protons, neutrons and electrons per atom in the two isotopes of carbon- atomic no: 6 and mass no: with 12 and 14	3
SECTION D		
17	a. Categorise the subatomic particles based on their properties. b. Draw the atomic structure of an element whose atomic number is 16. c. Identify the element and write the electronic configuration.	5
18	a. Explain Rutherford's alpha scattering experiment b. Draw the diagram of the experiment c. Mention his observations. d. On the basis of that explain the nuclear model of an atom.	5
SECTION E		
19	Cancer is a disease in which some of the body's cells grow uncontrollably and spread to other parts of the body. Cancer can start almost anywhere in the human body, which is made up of trillions of cells. Chemicals are used in the treatment of cancer. a. Mention an isotope used in the treatment of cancer. b. Nuclear reactors use nuclear fuel. Name the isotope that is used in nuclear reactors. c. Neeta is suffering from Goitre and she is undergoing radiation therapy. Mention the symptom of this disease and name the isotope used in its treatment.	4
20	A plum pudding with lots of dry fruits reminds us about the arrangement of subatomic particles. The discovery of subatomic particles waved off the claim that atoms are the fundamental unit of matter. a. Plum pudding model of an atom was proposed by J J Thomson. Explain his observation. b. Atom as a whole is electrically neutral. Elaborate. c. The model of an atom that was accepted worldwide was proposed by -----	4

ANSWER KEY

CHAPTER- 4 STRUCTURE OF THE ATOM.

Q NO	SECTION A	MARKS
1	c	1
2	b.	1
3	d.	1
4	b.	1
5	a.	1
6	b	1
7	b	1
8	b	1
SECTION B		
9	a.Isotope b.. Protium, Deuterium and Tritium	$\frac{1}{2}$ 1 $\frac{1}{2}$
10	Alpha particles are doubly charged helium ions and have a considerable amount of energy and they get deviated at 180 degree when they are hit on the positively charged heavy nucleus.	2
11	a.Isobars. Argon b.No: of protons-18 No: of neutrons-22 No: of electrons18	$\frac{1}{2}$ $\frac{1}{2}$
12	Valency of Nitrogen-3 No: of neutrons in Nitrogen-10 Valency of Chlorine-1 No: of neutrons in Chlorine-18	$\frac{1}{2}$ each
13	a. Magnesium b. 2,8,2 c. 2 d. 24	$\frac{1}{2}$ each
SECTION C		
14	a. $2n^2$ $n=5$ $2 \times 5^2 = 50$ b. Element -Oxygen Valency - 2 Valence electrons-6	$\frac{1}{2}$ each

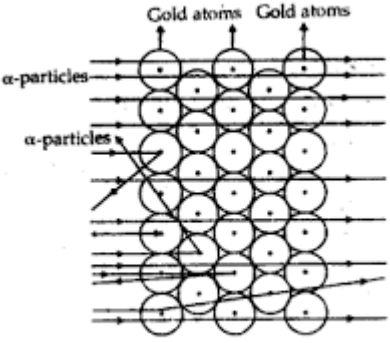
18	<p>a.</p> <p>Rutherford passed beams of alpha particles through a thin gold foil and noted how the alpha particles scattered from the foil.</p>  <p>Scattering of α-particles by a gold foil.</p> <p>Observations of Rutherford's alpha ray scattering experiment:</p> <ol style="list-style-type: none"> 1. Most of the α-particles passed straight through the gold foil without any deviation. 2. Some of the α-particles were deflected by the foil by some angles. 3. Interestingly one out of every 12,000 alpha particles appeared to rebound. <p>Nuclear model of an atom</p> <ol style="list-style-type: none"> i) There is a positively charged centre in an atom called the nucleus. Nearly all the mass of an atom resides in the nucleus. (ii) The electrons revolve around the nucleus in circular paths. (iii) The size of the nucleus is very small as compared to the size of the atom 	1 1 1 ½ 1 ½
SECTION E		
19	<p>a. Cobalt</p> <p>b. Uranium</p> <p>c. The person will have a swollen neck and the isotope of Iodine is used in its treatment.</p>	1 1 2
20	<p>a..An atom consists of a positively charged sphere and the electrons are embedded in it.</p> <p>(ii) The negative and positive charges are equal in magnitude. So, the atom as a whole is electrically neutral.</p> <ol style="list-style-type: none"> c. An atom is electrically neutral because its overall charge is zero. d. Neil's Bohr. 	2 1 1

CHAPTER – 5 THE FUNDAMENTAL UNIT OF LIFE

Q NO	SECTION A	MARKS
1	<p>Why is the cell called the structural and functional unit of life?</p> <p>a) Cells form the structure of an entity. A group of cells form a tissue, further an organ and ultimately an organ system.</p> <p>b) They perform fundamental functions and life processes such as respiration, digestion, excretion etc. in both unicellular and multicellular entities.</p> <p>(c) They perform all the activities independently.</p> <p>(d) All of these</p>	1
2	<p>The proteins and lipids, essential for building the cell membrane, are manufactured by</p> <p>(a) rough endoplasmic reticulum</p> <p>(b) Golgi apparatus</p> <p>(c) plasma membrane</p> <p>(d) mitochondria</p>	1
3	<p>Which structure contains genetic material and controls cell activities?</p> <p>a) Nucleus</p> <p>b) Cell wall</p> <p>c) Cell membrane</p> <p>d) Cytoplasm</p>	1
4	<p>Which of these options are not a function of Ribosomes?</p> <p>(i) It helps in manufacture of protein molecules</p> <p>(ii) It helps in manufacture of enzymes</p> <p>(iii) It helps in manufacture of hormones</p> <p>(iv) It helps in manufacture of starch molecules</p> <p>(a) (i) and (ii)</p> <p>(b) (ii) and (iii)</p> <p>(c) (iii) and (iv)</p> <p>(d) (iv) and (i)</p>	1
5	<p>Plasmolysis can be defined as</p> <p>(a) break down (lysis) of plasma membrane in hypotonic medium</p> <p>(b) shrinkage of cytoplasm in hypertonic medium</p> <p>(c) shrinkage of nucleoplasm</p> <p>(d) none of them</p>	1
6	<p>Identify the false sentences</p> <p>(a) Golgi apparatus is involved with the formation of lysosomes</p> <p>(b) Nucleus, mitochondria and plastid have DNA; hence they are able to make their own structural proteins</p> <p>(c) Mitochondria is said to be the powerhouse of the cell as ATP is generated in them.</p> <p>(d) Cytoplasm is called as protoplasm</p>	1
7	<p>Directions: In the following questions, a statement of assertion (A) is followed by a statement of reason (R). Mark the correct choice as:</p> <p>(a) Both assertion (A) and reason (R) are true and reason (R) is the correct explanation of assertion (A).</p> <p>(b) Both assertion (A) and reason (R) are true but reason (R) is not the</p>	1

	<p>correct explanation of assertion (A). (c) Assertion (A) is true but reason (R) is false. (d) Assertion (A) is false but reason (R) is true. Assertion : Mitochondria and chloroplasts are semiautonomous organelles. Reason : They are formed by division of pre-existing organelles and contain DNA but lack protein synthesizing machinery</p>	
8	<p>Assertion : Plant cells have very large vacuoles. Reason : In plant cells, vacuoles are full of cell sap.</p>	1
	SECTION B	
9	Lysosomes are known as ‘suicide-bags’ of a cell. Give reason	2
10	Endocytosis found in animals only? Analyse the reason?	2
11	The cell organelle which controls most of the activities of the cell? justify.	2
12	Peroxisomes mostly found in kidney and liver cells. Why?	2
13	Do you agree that Golgi bodies are found in large numbers in the cells which secrete digestive enzymes? If yes, explain why?	2
	SECTION C	
14	From your surroundings find out the different plant parts in which chromoplast, chloroplast and leucoplast are present ?.	3
15	With respect to the function, list three differences between a plasma membrane and cell wall?	3
16	What would happen if the cell has no nuclear membrane?	3
	SECTION D	
17	Illustrate a plant cell as you have seen it under a microscope in your practical class. Now label any three parts which you see here that is missing in an animal cell.	5
18	<p>a) Reetu has got cancer. Where will you find a greater number of ribosomes-in her body, In her cancer cells or in fat cells? b)If you are cooking vegetable curry today, after adding salt into the vegetables, you see that it released water . Why?</p>	5
	SECTION E	
19	<p>Mitochondria, often referred to as the “powerhouses of the cell”, were first discovered in 1857 by physiologist Albert von Kölliker. Later coined name as “bioblasts” (life germs) by Richard Altman in 1886. The organelles were then renamed “mitochondria” by Carl Benda twelve years later. Mitochondria are membrane-bound cell organelles (mitochondrion, singular) that generate most of the chemical energy needed to power the cell's biochemical reactions. Chemical energy produced by the mitochondria is stored in a small molecule called adenosine triphosphate</p>	4

(ATP). Mitochondria are found in all body cells, with the exception of a few. There are usually multiple mitochondria found in one cell, depending upon the function of that type of cell. Mitochondria are located in the cytoplasm of cells along with other organelles of the cell.



- a) Mitochondria are called the power house of the cell. Give reason?
- b) What is the location and function of mitochondria?
- c) What would happen if mitochondria is missing in the cell? .

20

4(1+1+2)

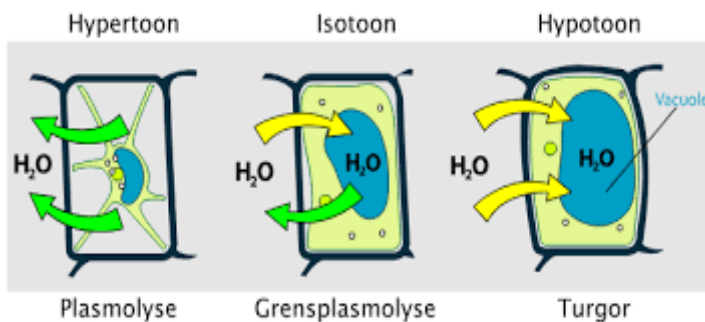

The cell membrane is a semipermeable membrane that separates the interior of all cells from the surrounding environment. The semipermeable membrane allows some particles, ions, or water molecules across the membrane, but blocks others. Water molecules constantly move inside and outside the cell across cell membranes. This free flow of water has the very important consequence of enabling cells to absorb water.

When a cell is placed in a hypertonic solution i.e., a solution in which concentration of water molecules outside the cell is lesser than the concentration of water molecules inside the cell, the cell will lose water by the process of osmosis (exosmosis). Although water crosses the cell membrane in both directions, but more water leaves the cell than enters resulting in the shrinkage of cell cytoplasm. This phenomenon of shrinkage of cell cytoplasm when put in a hypertonic solution is called plasmolysis. If the water moving in and out of the cell is in equilibrium, the cells are said to be flaccid.

- a) What is plasmolysis?

b)What would you predict to happen if you put the cell in a solution which is having the same amount of solute concentration as inside the cell?

c)If Geetha places a plasmolysed cell in a hypotonic solution,What do you think would happen to the cell? What term can you give such a cell after the process?

ANSWER KEY CHAPTER – 5 THE FUNDAMENTAL UNIT OF LIFE

Q NO	SECTION A	MARKS
1	d	1
2	a	1
3	a	1
4	c	1
5	b	1
6	d	1
7	c	1
8	a	1
	SECTION B	
9	If the cell gets damaged, then one of the lysosomes bursts and release some digestive enzymes. The released enzymes then digest their own cell and ultimately the cell dies. Hence, lysosomes are called suicide bags of the cell	2
10	For endocytosis to occur, the outermost membrane should be flexible like the plasma membrane of animals. But in plant cells, cell wall is the outermost membrane which is very rigid. Hence, endocytosis occurs only in animals and not in plants.	2

11	Nucleus, also known as the brain of the cell, controls most of the activities of the cell because it contains DNA (Deoxyribonucleic acid) which contains all the information of the cell.	2
12	Peroxisomes contain various oxidative enzymes which detoxify the toxic material. Since the blood carries various toxic substances to kidney and liver, a large number of peroxisomes are present in them to oxidize the toxic material.	2
13	The main function of Golgi bodies is to release proteins or enzymes by vesicles. No other organelle has this property. Therefore, these are largely present in secreting cells.	2
SECTION C		
14	Chromoplasts are present in flowers, fruits or any other coloured part of the plant other than green part. Chloroplasts are present in leaves and stem of plant or green part. Leucoplasts are present anywhere in plant as they are colourless and store food.	3
15	Plasma membrane 1. It holds cellular contents and controls passage of materials in and out of cell.2. It is semipermeable in nature and allows entry of selected molecules into the cell.3. It is not elastic. Cell wall 1. It gives protection, strength and rigidity to the cell.2. It is completely permeable in nature.3. It is elastic and controls the cell's turgidity preventing its bursting.	3
16	The environment of nucleus would not be separated from that of rest of the cell. No protection of genetic material from damage. exchange of materials in and out of the nucleus would be missing.	3
SECTION D		
17	Diagram of a plant cell chloroplast, vacuole, cell wall	5
18	a) Ribosomes are found in greater number in Rectus actively dividing cells which are the cancer cells as they need more amount of proteins for the formation of new cells. b) When salt is added, a hypotonic medium is created, the concentration of salt molecules is more outside the vegetables than inside. Due to osmosis water from the vegetables came out.	5
SECTION E		
19	a) Mitochondria are known as the powerhouse of the cell because it is responsible for the extracting energy from food through cellular respiration. The energy is released in the form of adenosine triphosphate (ATP). It is an energy currency of the cell.	4(1+2+1)

	<p>b) Mitochondrion, are found in the cytoplasm of almost all eukaryotic cells (cells with clearly defined nuclei), the primary function of which is to generate large quantities of energy in the form of adenosine triphosphate (ATP)</p> <p>c) lack of a mitochondria would mean the cell wouldn't have the necessary energy to live. So the cell would mostly die due to very low or no energy levels.</p>	
20	<p>a) Plasmolysis is the process of shrinkage or contraction of the protoplasm of a plant cell as a result of loss of water from the cell</p> <p>b) the water moving in and out of the cell will be in equilibrium,</p> <p>c)When a plasmolyzed cell is placed in a hypotonic solution, (i.e., the solution having solute concentration lower than the cell sap), the water moves into the cell because of the higher concentration of water outside the cell than in the cell. The cell then swells to become turgid.</p> <p>We can call it a deplasmolysed cell.</p>	4(1+1+2)

CHAPTER – 6 TISSUES

Q NO	SECTION A	MARKS
1	Identify the meristem which increases the girth of stem (a) apical meristem (b) lateral meristem (c) intercalary meristem (d) vertical meristem.	1
2	Intestine absorbs the digested food materials. What type of epithelial cells are responsible for that? (a) Stratified squamous epithelium (b) Columnar epithelium (c) Spindle fibres (d) Cuboidal epithelium	1
3	A person met with an accident in which two long bones of hand were dislocated. Find out the possible reason among the following (a) Tendon break (b) Break of skeletal muscle (c) Ligament break (d) Areolar tissue break	1
4	Select among the given muscles Which act involuntarily (i) Striated muscles (ii) Smooth muscles (iii) Cardiac muscles (iv) Skeletal muscles (a) (i) and (ii) (b) (ii) and (iii) (c) (iii) and (iv) (d) (i) and (iv)	1
5	Which is not a function of epidermis? (a) Protection from adverse condition (b) Gaseous exchange (c) Conduction of water (d) Transpiration.	1
6	The muscular tissue which function through-out the life continuously without fatigue is (a) skeletal muscle (b) cardiac muscle (c) smooth muscle (d) voluntary muscle.	1
7	Directions: In each of the following questions, a statement of Assertion is given and a corresponding statement of Reason is given just below it. Of the statements, given below, mark the correct answer as: (a) Both assertion and reason are true and reason is the correct explanation of assertion. (b) Both assertion and reason are true but reason is not the correct explanation of assertion.	1

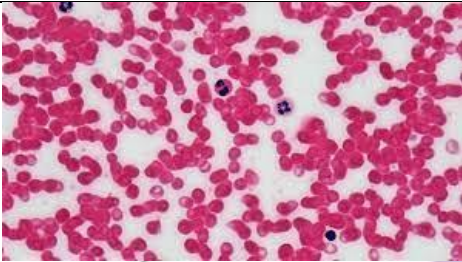
	(c) Assertion is true but reason is false. (d) Assertion is false but reason is true Assertion : Parenchyma cells help in storage of food. Reason : Parenchyma cells are the main seats of photosynthesis.	
8	Assertion : Permanent tissue is composed of mature cells. Reason : Meristematic tissue is a group of actively dividing cells.	1
SECTION B		
9	Differentiate the following activities on the basis of voluntary (V) or involuntary (IV) muscles. (a) Jumping of frog (b) Pumping of the heart (c) Writing with hand (d) Movement of chocolate in your intestine [NCERT Exemplar]	2
10	Water hyacinth floats on water surface. Give reason [NCERT Exemplar].	2
11	Which structure protects the plant body against the invasion of parasites? [NCERT Exemplar]	2
12	An organism—plant or animal, require different types of cells in the body. Justify	2
13	If a potted plant is covered with a glass jar, water vapour appears on the wall of the glass jar. Why?	2
SECTION C		
14	Why are xylem and phloem called complex tissues? How are they different from one other ? [NCERT Exemplar]	3
15	List the characteristics of cork. How are they formed?	3
16	A nail is inserted in the trunk of a tree at a height of 1 metre from the ground level. After 3 years, where will the nail be present? Give reason	3
SECTION D		
17	Tissue A and tissue B constitute tissue C. A carries water while B carries food for the plants. Identify A, B, C Draw and identify different elements of A and B	5
18	Give reasons for: a. Meristematic cells have a prominent nucleus and dense cytoplasm but they lack vacuole. b. Intercellular spaces are absent in sclerenchyma tissues. c. We get a crunchy and granular feeling when we chew pear fruit. d. Branches of a tree move and bend freely in high wind velocity. e. It is difficult to pull out the husk of a coconut tree.	5
SECTION E		
19		4

	<p>Blood is a type of connective tissue. The cells of connective tissue are loosely spaced and embedded in an intercellular matrix. The matrix may be jelly like, fluid, dense or rigid. The nature of matrix differs in concordance with the function of the particular connective tissue.</p> <p>Blood has a fluid (liquid) matrix called plasma, in which red blood corpuscles (RBCs), white blood corpuscles (WBCs) and platelets are suspended. The plasma contains proteins, salts and hormones. Blood flows and transports gases, digested food, hormones and waste materials to different parts of the body.</p> <p>Bone is another example of a connective tissue. It forms the framework that supports the body. It also anchors the muscles and supports the main organs of the body. It is a strong and nonflexible tissue. Bone cells are embedded in a hard matrix that is composed of calcium and phosphorus compounds. Two bones can be connected to each other by another type of connective tissue called the ligament. This tissue is very elastic.</p> <p>Another type of connective tissue, cartilage, has widely spaced cells. The solid matrix is composed of proteins and sugars. Cartilage smoothens bone surfaces at joints and is also present in the nose, ear, trachea and larynx</p> <p>a. Identify the connective tissue by which two bones are connected to each other b. Give 4 examples of connective tissue c What are the function of connective tissue?</p>	
20	<p>The nervous tissue, which contains densely packed nerve cells, called neurons (Gk. neuro = nerve), is present in the brain, spinal cord and nerves. The neurons are specialised for conduction of nerve impulses.</p> <p>a. What is a neuron? b Write the structure and functions of a neuron. c Draw and label the structure of a neuron.</p>	4

ANSWER KEY CHAPTER - 6 TISSUES

Q NO	SECTION A	MARKS
1	(b)	1
2	(b)	1
3	(c).	1
4	(b)	1
5	(c).	1
6	(b)	1
7	(b)	1
8	(b)	1
SECTION B		
9	(a) Vountary (b) involuntary (c) Voluntary (d) involuntary	2
10	Aerenchyma present in the swollen petiole provides buoyancy to the hyacinth. Thus, it floats on water surface.	2
11	The epidermis has thick cuticles and waxy substances to prevent the invasion of parasite	2
12	Any organism will have a wide range of cell types. This is because each cell type specialises in one particular function. And for the proper working of an organism many functions like food transport, immunity, strength, etc., are needed to be performed properly	2
13	This happens because of transpiration due to which water is released from the plant in the form of water vapour which appears on the glass jar.	2
SECTION C		
14	Xylem and phloem are called as complex tissues as they are made up of more than one type of cells. Any two differences	3
15	The characteristics of cork (any 2) <ul style="list-style-type: none"> • Cells of cork are dead at maturity. • ,Compactly arranged, • do not possess intercellular space., • Cells possess a chemical substance ‘suberin’ in their walls. • There are several thick layers. <p>As plants grow older, a strip of secondary meristem replaces the epidermis of the stem. Cells on the outside are cut off from this layer. This forms the several-layer thick cork or the bark of the tree.</p>	3
16	The nail will remain at the same position even after 3 years. This is because a plant or tree grows from its tip (stem or root) not from the point at which it joins the ground. So, the tree will grow but the nail will remain at the same place on the tree trunk.	3
SECTION D		

17	<p>Tissue A and tissue B constitute tissue C. A carries water while B carries food for the plants. Identify A, B, C</p> <p>Draw and identify different elements of A and B</p> <p>I. Xylem B...phloem c....vascular tissue</p> <p>Diagram and labelling</p>	5
18	<p>a. Vacuoles basically serve the purpose of storing nutrients, excess salts, etc. Meristematic cells do not need to store these nutrients. They are specialized cells. Their main role is to divide and grow. Hence, they are very active, and have dense cytoplasm, and prominent nuclei, but they lack vacuoles.</p> <p>b. Cells of sclerenchyma tissue have thick cell walls due to lignin. Due to the thick cell wall, intercellular spaces are absent in sclerenchyma tissue.</p> <p>c. In pear fruit, sclerenchyma cells are called stone cells. They are small, thick, and hard. That is why we get a crunchy and granular feeling when we chew pear fruit.</p> <p>d. Branches of a tree move and bend freely in high wind velocity due to the presence of a permanent tissue called collenchyma. Collenchyma provides flexibility in plants. It allows the bending of various parts of a plant.</p> <p>e. The husk of a coconut tree contains sclerenchyma tissue. This tissue makes the plant hard and stiff. That is why it is difficult to pull out the husk of a coconut tree.</p>	5
SECTION E		
19	<p>a Ligament</p> <p>b Blood, Bone, Ligament, cartilage</p> <p>c Binding together other tissues (any two)</p> <p>Supporting various parts of the body</p> <p>Forming a packing around organs</p>	4
20	<p>a Neurons are the structural and functional unit of the nervous system.</p> <p>b All neurons have three different parts – dendrites, cell body and axon. The neuron structure is specially adapted to carry messages over large distances in the body quickly in the form of electrical signals.</p>	4

CHAPTER – 7 MOTION

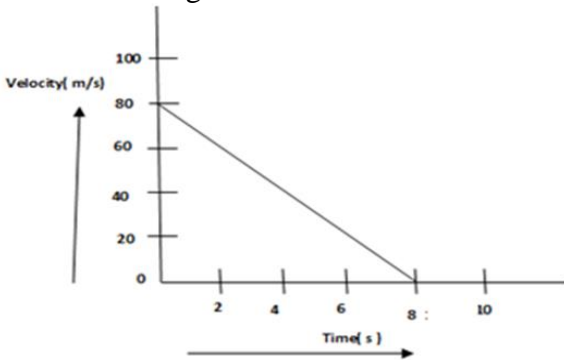
Q NO	SECTION A	MARKS
1		1
2	When v-t graph is parallel to x-axis a. The body is at rest b. The body is at uniform acceleration c. The body is at uniform retardation d. The body is at uniform velocity	1
3	Velocity versus time graph of an object rolling on a concrete floor is shown in the figure below. The area inside the triangle represents  <p>The graph shows Velocity (m/s) on the vertical axis and Time (s) on the horizontal axis. The vertical axis has markings at 0, 20, 40, 60, 80, and 100. The horizontal axis has markings at 0, 2, 4, 6, 8, and 10. A straight line starts at (0, 80) and ends at (8, 0), forming a right-angled triangle with the time axis.</p> a. acceleration b. displacement c. speed d. velocity	1
4	Which of the following statements is correct? a. Both speed and velocity are vector quantities b. Speed is a scalar and velocity is a vector c. Speed is a vector and velocity is scalar d. Both speed and velocity are scalar quantities	1
5	A particle is moving in a circular path of radius x cm. The displacement after half a circle would be: a. Zero b. $3.14x$ c. $2x$ d. $6.28x$	1
6	Identify quantity whose unit is m/s a. Speed b. Velocity c. Acceleration d. Displacement	1
7	ASSERTION: A passenger sitting in a moving bus is at rest with respect to his fellow passenger but he is in motion with respect to a man standing outside REASON: Motion is relative a. Both assertion (A) and reason (R) are true and reason (R) is the correct explanation of assertion (A). b. Both assertion (A) and reason (R) are true but reason (R) is not	1

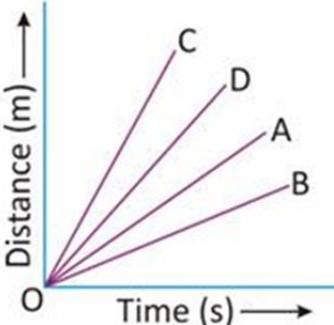
	<p>the correct explanation of assertion (A).</p> <p>c. Assertion (A) is true but reason (R) is false.</p> <p>d. Assertion (A) is false but reason (R) is true.</p>	
8	<p>ASSERTION: A moving object can have zero velocity</p> <p>REASON: velocity is speed with direction</p> <p>a. Both assertion (A) and reason (R) are true and reason (R) is the correct explanation of assertion (A).</p> <p>b. Both assertion (A) and reason (R) are true but reason (R) is not the correct explanation of assertion (A).</p> <p>c. Assertion (A) is true but reason (R) is false.</p> <p>d. Assertion (A) is false but reason (R) is true.</p>	1
	SECTION B	
9	Define uniform acceleration. What is the acceleration of a body moving with uniform velocity?	2
10	Represent uniform and nonuniform motion with the help of distance time graphs	2
11	<p>Four cars A, B, C and D are moving on a levelled, straight road. Their distance time graphs are shown in the figure below. Which car is the fastest? Why?</p> 	2
12	Differentiate between distance and displacement?	2
13	Draw a velocity versus time graph of a stone thrown vertically upwards and downwards after attaining the maximum height.	2
	SECTION C	
14	<p>A car travels from stop A to stop B with a speed of 30 km/h and then returns back to A with a speed of 50 km/h. Calculate</p> <p>a. displacement of the car.</p> <p>b. average speed of the car</p>	3
15	<p>Arun swims in a square shaped swimming pool of 100m side. After observing the pattern of his motion Sarita made two statements. Evaluate the statements as true or false with valid reasons</p> <p>a. Magnitude of displacement by Arun is more than the distance travelled by him</p> <p>b. Displacement by Arun can never be zero</p>	3

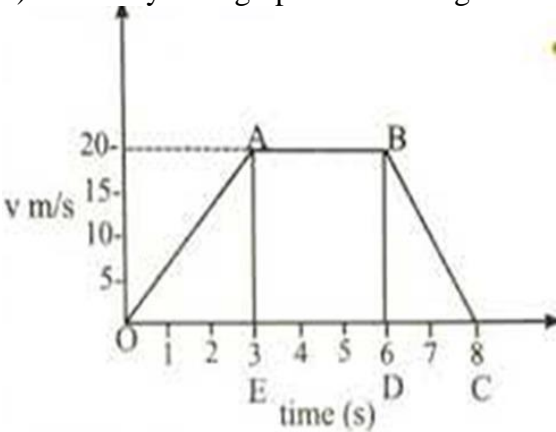
16 a	A signal from a spaceship reached the ground station in 10 minutes. Calculate the distance of the spaceship from the ground station. (Speed of light = 3×10^8 ms ⁻¹) What does the odometer of a car measures?	3												
b	SECTION D													
17 a	A train starting from rest attains a velocity of 36km/ h in 1 minute. Assuming that the acceleration is uniform, find (i) the acceleration of the train (ii) the distance travelled by the train for attaining this velocity Write any two-point difference between scalar and vector quantities	5												
b														
18	a)A velocity time graph of a moving car is shown in the graph  i) Which part of the graph shows zero acceleration? ii)What is the minimum and maximum speed attained by the car? iii)How long the car is showing uniform acceleration? iv) What is the distance travelled by the car in last 2 seconds?	5												
SECTION E														
19	he following table gives the data about motion of a car. <table border="1" data-bbox="319 1456 1181 1579"> <tr> <td>Time (h)</td> <td>10.00</td> <td>10.30</td> <td>11.00</td> <td>11.30</td> <td>12.00</td> </tr> <tr> <td>Distance (km)</td> <td>0</td> <td>25</td> <td>50</td> <td>75</td> <td>100</td> </tr> </table> a. Find the speed of the car between 11.00 hours and 11.30 hours. b. What is the average speed of the car? c. Identify the type of motion exhibited by the car? Justify your answer with valid reason	Time (h)	10.00	10.30	11.00	11.30	12.00	Distance (km)	0	25	50	75	100	4
Time (h)	10.00	10.30	11.00	11.30	12.00									
Distance (km)	0	25	50	75	100									
20 a. b. c.	Two girls A and B are sitting on a merry- go- round exactly opposite to one another, A at the right and B at the left side at a distance of 4m from one another. The merry-go-round is moving with a constant speed of 10m/s and takes 2 minutes to complete one circle. The motion on merry-go-round is an example of which type of motion? Calculate the maximum displacement obtained by the child B “Uniform circular motion is accelerated “justify the statement	4												

ANSWER KEY

CHAPTER - 7 MOTION

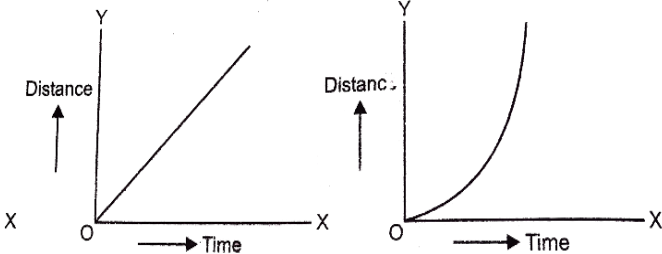
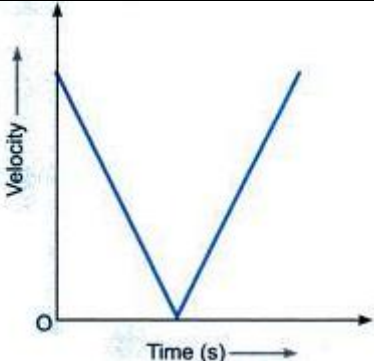
Q NO	SECTION A	MARKS								
1		1								
2	d. The body is at uniform velocity	1								
3	b. displacement	1								
4	b. Speed is a scalar and velocity is a vector	1								
5	c. 2x	1								
6	a. Speed	1								
7	a. Both assertion (A) and reason (R) are true and reason (R) is the correct explanation of assertion (A).	1								
8	b. Both assertion (A) and reason (R) are true but reason (R) is not the correct explanation of assertion (A).	1								
SECTION B										
9	a) If an object's rate of change of velocity is uniform it is said to be under uniform acceleration. b) Zero	1 1								
10		1+1								
11	Car C is fastest It covered maximum distance in minimum time	1 1								
12	<table border="1" style="width: 100%; border-collapse: collapse;"> <thead> <tr> <th style="width: 50%;">Distance</th> <th style="width: 50%;">Displacement</th> </tr> </thead> <tbody> <tr> <td>1. The total path covered by an object.</td> <td>1. The shortest distance from the final position to the initial position.</td> </tr> <tr> <td>2. It is a scalar quantity.</td> <td>2. It is a vector quantity.</td> </tr> <tr> <td>3. It is always positive.</td> <td>3. It can be positive(or) zero(or) negative.</td> </tr> </tbody> </table>	Distance	Displacement	1. The total path covered by an object.	1. The shortest distance from the final position to the initial position.	2. It is a scalar quantity.	2. It is a vector quantity.	3. It is always positive.	3. It can be positive(or) zero(or) negative.	Any two 1+1
Distance	Displacement									
1. The total path covered by an object.	1. The shortest distance from the final position to the initial position.									
2. It is a scalar quantity.	2. It is a vector quantity.									
3. It is always positive.	3. It can be positive(or) zero(or) negative.									
13		2								
SECTION C										
14	a. 0	1/2								

	<p>b) Distance from A to B = x</p> <p>Average speed = $\frac{\text{Total distance}}{\text{Total time taken}}$</p> <p>Time taken to travel from A to B</p> <p>Time = $\frac{\text{distance}}{\text{Speed}} = \frac{x}{30} \text{ h}$</p> <p>Time taken to travel from B to A</p> <p>$= \frac{x}{50} \text{ h}$</p> <p>Average Speed = $\frac{2x}{\left(\frac{x}{30} + \frac{x}{50}\right)} = \frac{2x}{\frac{5x+3x}{150}}$</p> <p>$= \frac{300x}{8x} = 37.5 \text{ km/h}$</p>	<p>1/2</p> <p>1</p> <p>1</p>
15	<p>a. False. Displacement is always less than or equal to distance</p> <p>b. False Displacement can zero</p>	<p>1/2+1</p> <p>1/2+1</p>
16	<p>(Speed of light = $3 \times 10^8 \text{ ms}^{-1}$)</p> <p>a Time is taken by signal = 10 min</p> <p>1 minute = 60 sec</p> <p>10min = $10 \times 60 \text{ sec} = 600 \text{ sec}$</p> <p>Distance of spaceship from ground station = $3 \times 10^8 \times 600 = 18 \times 10^{10} \text{ m}$</p> <p>b speed</p>	<p>2</p> <p>1</p>
SECTION D		
17	<p>a. Acceleration</p> <p>u=0</p> <p>v=36km/h=10m/s</p> <p>a=v-u/t=10/60=1/6m/s²</p> <p>b. the distance travelled by the train for attaining this velocity</p> <p>s=v²-u²/2a =600/2=300m</p> <p>any two difference</p> <p>b</p>	<p>1/2</p> <p>1/2</p> <p>1+1</p> <p>2</p>
18	<p>a. AB</p> <p>b. minimum speed 0 m/s maximum speed =20m/s</p> <p>c.3 seconds</p> <p>d. area of BDC=1/2bh=1/2x3x20=30m</p>	<p>1</p> <p>1</p> <p>1</p> <p>2</p>
SECTION E		
19	<p>a). Distance=25 km time=0.5 h speed=distance/time</p> <p>25/0.5=50 km/h</p> <p>b). average speed =100/2=50km/h</p> <p>c). uniform motion. equal distance covered in equal time intervals</p>	<p>1</p> <p>1</p> <p>2</p>
20	<p>(a) Circular motion</p> <p>(b) 8m</p> <p>(c) The velocity changes due to continuous change in the direction</p> <p>So, even when the body moves to a constant speed, its velocity is not constant. As there is change in velocity it is accelerated</p>	<p>1</p> <p>1</p> <p>2</p>

CHAPTER – 8 FORCE AND LAWS OF MOTION

Q NO	SECTION A	MARKS
1	Swimming is possible by the a) first law of motion b) second law of motion c) third law of motion d) Newton's law of gravitation	1
2	A cricket player catches a ball of mass 0.1 kg, moving with a speed 10 m/s in 0.1 second. Force exerted by him is (N) a) 4 b) 2 c) 1 d) 10	1
3	Which of the following has the largest inertia? a) A pin b) A pen c) Your notebook d) Your trolley bag	1
4	The inertia of an object causes the object to a) decrease its speed b) Increase its speed c) resist any change in the state of its motion d) decelerate due to friction	1
5	If the mass of the body is doubled and its velocity becomes half, then the linear momentum of the body will a) become double b) remain the same c) become half d) become four times	1
6	The linear momentum of an object is 250 g cm/s. If the velocity of the object is 5 m/s, then the mass of the object is a) 0.5 g b) 5 kg c) 0.5 mg d) 5 mg	1
7	Directions: In the following questions, a statement of assertion (A) is followed by a statement of reason (R). Mark the correct choice as: (a) Both assertion (A) and reason (R) are true and reason (R) is the correct	1

	<p>explanation of assertion (A). (b) Both assertion (A) and reason (R) are true but reason (R) is not the correct explanation of assertion (A). (c) Assertion (A) is true but reason (R) is false. (d) Assertion (A) is false but reason (R) is true.</p> <p>Assertion : When a bee hits a bus, each of them exerts the same force. Reason : . The bee has more mass as compared to the windshield.</p>	
8	<p>Assertion : A body is momentarily at rest when it reverses the direction. Reason : A body cannot have acceleration if its velocity is zero at a given instant of time.</p>	1
SECTION B		
9	<p>Suppose a ball of mass m is thrown vertically upwards with an initial speed v, its speed decreases continuously till it becomes zero. Therefore, the ball begins to fall downward and attains the speed v again before striking the ground. It implies that the magnitude of initial and final momenta of the ball are the same. Yet, it is not an example of conservation of momentum. Explain why?.</p>	2
10	<p>List two factors on which friction depends?</p>	2
11	<p>A bullet fired against a glass window pane makes a hole in it, and the glass pane is not cracked. But, when a stone strikes the same glass pane, it gets shattered. Why is it so?</p>	2
12	<p>Neha is walking on the road. Describe her walking in terms of Newton's third law of motion.</p>	2
13	<p>There are three balls made up of aluminium, steel and thermocol, of the same shape and same volume. Which of them will have the highest inertia?</p>	2
SECTION C		
14	<p>You are given a pile of carrom coins. Describe in brief an activity to illustrate the property of inertia of rest?</p>	3
15	<p>Ram and Shyam are on roller-skates. They are standing 5 m apart facing each other. Ram throws a ball of 2 kg towards Shyam, who catches it. How will this activity affect the position of the two? Explain.</p>	3
16	<p>What is the relationship between mass and inertia? Explain illustrating two examples.</p>	3

SECTION D		
17	<p>Using the second law of motion, derive the unit of force.</p> <p>A force of 5 N produces an acceleration of 8 m s^{-2} on a mass m and an acceleration of 24 m s^{-2} on a mass m_2. What acceleration would the same force provide if both the masses are tied together?</p>	5
18	<p>Explain momentum? Write down its SI unit. Interpret force in terms of momentum. Represent the given situation graphically. (ncert exemplar)</p> <p>(a) momentum versus velocity when mass is fixed.</p> <p>(b) momentum versus mass when velocity is constant.</p>	5
SECTION E		
19	<p><u>Read the given information and answer the following questions:</u></p>  <p>CASE- When one object exerts a force on another object, the second object instantaneously exerts a force back on the first. These two forces are always equal in magnitude but opposite in direction. These forces act on different objects and never on the same object. It is important to note that even though the action and reaction forces are always equal in magnitude; these forces may not produce accelerations of equal magnitudes, this is because each force acts on a different object that may have a different mass. The two opposing forces are also known as action and reaction forces</p> <p>1. Complete the sentence: Action reaction forces are always----- and -----in direction</p> <p>2. Give two examples of the third law of motion.</p> <p>3. justify the statement: Even though the action and reaction forces are always equal in magnitude, these forces may not produce accelerations of equal magnitudes.</p>	4
20		4

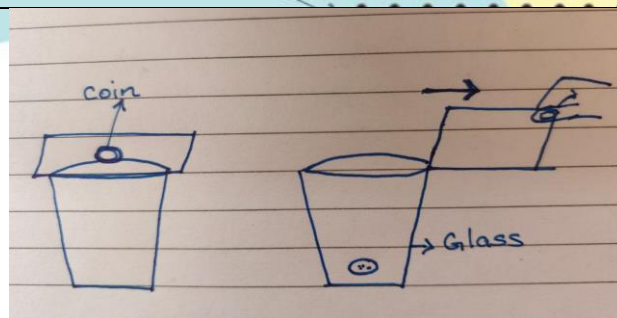

Take a glass tumbler and place a thick square card on its mouth. A coin is then placed above this card in the middle. flick the card hard with your fingers. The card moves away but the coin drops into the glass tumbler.

Newton's first law of motion states that a body at rest will remain at rest and a body which is in motion continues to be in motion unless otherwise they are acted upon by an external force. In other words, all objects resist a change in their state of motion. In a qualitative way, the tendency of undisturbed objects to stay at rest or to keep moving with the same velocity is called inertia. This is why the first law of motion is also known as the law of inertia.

1. What happens if no external force acts on a moving object with respect to its speed and direction?
2. State Newton's first law of motion.
3. Newton's first law of motion is called the law of inertia. Justify.

ANSWER KEY CHAPTER - 8 FORCE AND LAWS OF MOTION

Q NO	SECTION A	MARKS
1	c	1
2	d	1
3	d	1
4	c	1
5	b	1
6	a	1
7	c	1
8	c	1
	SECTION B	

9	Law of conservation of momentum is applicable to isolated systems (no external force is applied). In this case, the change in velocity is due to the gravitational force of earth.	2
10	The force of friction is directly proportional to the weight of the body sliding over the surface. The force of friction also depends on the nature of the surfaces in contact.	2
11	When the bullet strikes the glass pane, the part of the glass pane which comes in contact with the bullet shares the large velocity of the bullet and makes a hole, while the remaining part of the glass remains at rest and is therefore not shattered due to inertia of rest. But when a slow-moving stone strikes the same glass pane, the various parts of the glass pane get enough time to share the velocity of the stone, and the glass is shattered.	2
12	When Neha walks on the road, her foot pushes the ground backward (action) and the ground pushes her foot forward (reaction). Thus, the forward reaction exerted by the ground on her foot makes her walk forward.	2
13	Steel has the highest inertia. As the mass is a measure of inertia, the ball of the same shape and size, having more mass than other balls, will have the highest inertia. Steel has the greatest density and greatest mass; therefore, it has highest inertia.	2
SECTION C		
14	<ul style="list-style-type: none"> • Make a pile of similar carom coins on a table. • Attempt a sharp horizontal hit at the bottom of the pile using another carrom coin or the striker. If the hit is strong enough, the bottom coin moves out quickly. Once the lowest coin is removed, the inertia of the other coins makes them 'fall' vertically on the table. • The inertia of coins tries to maintain its state of rest even when one of the coins moves out. 	3
15	Separation between Ram and Shyam will increase. Initially the momentum of both of them are zero as they are at rest. In order to conserve the momentum Ram who throws the ball would move backward. Shyam will experience a net force after catching the ball and therefore will move backwards that is in the direction of the force.	3
16	The mass of a body is a measure of its inertia. It means larger the mass of a body, larger will be the inertia offered by the body to change its state of motion. examples to clarify it:	3

	<p>1. When we kick a football, it flies a long way but at the same time if we kick a stone of the same size, it hardly moves, as the stone resists a change in its motion better than the football because of its more mass.</p> <p>2. We can increase the velocity of our bicycle by pedaling harder, i.e., by applying more force. But the same force will produce a negligible change in the motion of a motorcycle, because in comparison to the bicycle, a motorcycle has more tendency to oppose the change in its state of motion because of its larger mass</p>	
	SECTION D	
17	<p>Using the relationship, $F = ma$ If m is measured in kg and a is measured in m s^{-2} Then the unit of force is kg m s^{-2} $1 \text{ kg m s}^{-2} = 1 \text{ N}$</p> <p>$F = 5 \text{ N}, a_1 = 8 \text{ m s}^{-2}, a_2 = 24 \text{ m s}^{-2}$ $\therefore m_1 = \frac{F}{a_1} = \frac{5}{8} \text{ kg}$ and $m_2 = \frac{F}{a_2} = \frac{5}{24} \text{ kg}$</p> <p>Now, total mass when both the masses are tied together,</p> $m = m_1 + m_2 = \left(\frac{5}{8} + \frac{5}{24} \right) \text{ kg}$ $= \left(\frac{15+5}{24} \right) \text{ kg} = \frac{20}{24} \text{ kg} = \frac{5}{6} \text{ kg}$ <p>\therefore Acceleration, $a = \frac{F}{m} = \frac{5}{5/6} = 6 \text{ m s}^{-2}$</p>	5
18	<p>Momentum is a property of a moving body by the virtue of both its mass and velocity. It is equal to the product of mass and velocity. $p = m \times v$ Its SI unit is kg ms^{-1} As momentum = mass x velocity</p> <p>Force= rate of change of momentum (a) When mass is fixed When m is constant momentum is directly proportional to velocity. momentum \propto velocity</p>	5

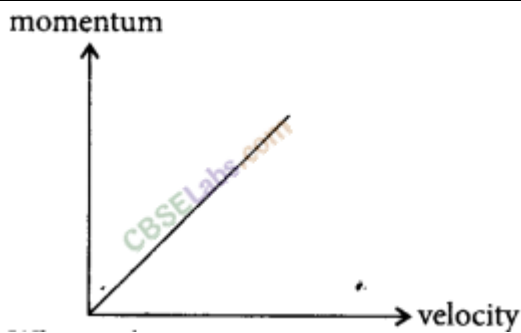

(b) When velocity is constant, momentum will be directly proportional to mass
 $\text{momentum} \propto \text{mass}$

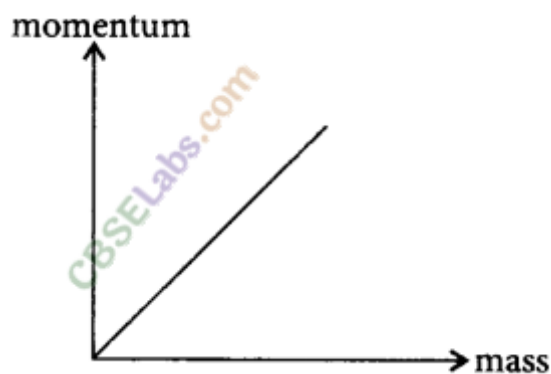

	SECTION E	
19	<p>1. equal and opposite</p> <p>2. Any 2 examples (Swimming or rowing a boat. <ul style="list-style-type: none"> • Static friction while pushing an object. • Walking. • Standing on the ground or sitting on a chair.) </p> <p>3. These action reaction forces are acting on two different objects having different masses that's why they produce acceleration with different magnitude.</p>	4(1+2+1))
20	<p>1. Continue to move with same speed in same direction</p> <p>2. Newton's first law of motion states that a body at rest will remain at rest position only and a body which is in motion continues to be in motion unless otherwise they are acted upon by an external force.</p> <p>3. All objects resist a change in their state of motion. In a qualitative way, the tendency of undisturbed objects to stay at rest or to keep moving with the same velocity is called inertia. So, the first law of motion is also known as the law of inertia.</p>	4(1+1+2))

CHAPTER- 9 GRAVITATION

Q NO	SECTION A	MARKS
1	The value of acceleration due to gravity (a) is same on equator and poles (b) is least on poles (c) is least on the equator (d) increases from pole to equator	1
2	Law of gravitation gives the gravitational force between (a) the earth and a point mass only (b) the earth and Sun only (c) any two bodies having some mass (d) two charged bodies only	1
3	An object weighs 10 N in air. When immersed fully in water, it weighs only 8 N. The weight of the liquid displaced by the object will be (a) 2 N (b) 8 N (c) 10 N (d) 12 N	1
4	Two particles are placed at some distance. If the mass of each of the two particles is doubled, keeping the distance between them unchanged, the value of gravitational force between them will be a)1/4 times (b) 4 times (c) 1/2 times (d) unchanged	1
5	The weight of an object at the center of the earth of radius R is (a) zero (b) infinite (c) R times the weight at the surface of the earth (d) 2R times the weight at surface of the earth	1

6	<p>A girl stands on a box having 60 cm length, 40 cm breadth and 20 cm width in three ways. In which of the following cases, pressure exerted by the brick will be</p> <p>(a) maximum when length and breadth form the base</p> <p>(b) maximum when breadth and width form the base</p> <p>(c) maximum when width and length form the base</p> <p>(d) the same in all the above three cases</p>	1
7	<p>Directions: In each of the following questions, a statement of Assertion is given, and a corresponding statement of Reason is given just below it. Of the statements, given below, mark the correct answer as:</p> <p>(a) Both assertion and reason are true and reason is the correct explanation of assertion.</p> <p>(b) Both assertion and reason are true but reason is not the correct explanation of assertion.</p> <p>(c) Assertion is true but reason is false.</p> <p>(d) Assertion is false and Reason are true.</p> <p>Assertion: When distance between two bodies is doubled and also mass of each body is doubled, then the gravitational force between them remains the same.</p> <p>Reason: According to Newton's law of gravitation, product of force is directly proportional to the product mass of bodies and inversely proportional to square of the distance between them</p>	1
8	<p>Assertion: In day-to-day life, we do not feel a gravitational pull on each other.</p> <p>Reason: Gravitational forces do not act on human bodies.</p>	1
SECTION B		
9	<p>If the small and big stones are dropped from the roof of a house simultaneously, they will reach the ground at the same time. Why?</p>	2
10	<p>Mention any four phenomena that the universal law of gravitation was able to explain</p>	2

11	Why does a body reach the ground quicker at poles than at the equator, when dropped from the same height?	2
12	A force of 20 N acts upon a body whose weight is 9.8 N. What is the mass of the body and how much is its acceleration? Take $g = 9.8 \text{ m/s}^2$.	2
13	It difficult to hold a school bag having a strap made of a thin and strong string... Why?	2
SECTION C		
14	Why does an object float or sink when placed on the surface of water?	3
15	A stone dropped from the roof of a building takes 4s to reach the ground. Calculate the height of the building.	3
16	A stone is dropped from a height of 10 m on an unknown planet having $g = 20 \text{ m/s}^2$. Calculate the speed of the stone when it hits the surface of the planet. Also, calculate the time it takes to fall through this height.	3
SECTION D		
17	(a) Define pressure. State its SI unit. (b) The dimensions of a metallic cuboid are $30 \text{ cm} \times 20 \text{ cm} \times 15 \text{ cm}$, and its mass is 30 kg. If the acceleration due to gravity is 10 m/s^2 , calculate the pressure exerted by the cuboid when it rests on the face with sides $20 \text{ cm} \times 15 \text{ cm}$ on the table. (c) In which of the following situations do we exert more pressure on the ground? Whether standing on the foot or standing on both feet? Justify the answer.	5
18	(a) A metallic bar has a 200 g mass at poles. Does it change when it is taken to the equator? (b) Is there any weight change when brought to the equator? (c) What would happen when there is no acceleration due to gravity? (d) Differentiate between acceleration due to gravity and universal gravitational constant (e) Derive a relation between G and g.	5

SECTION E

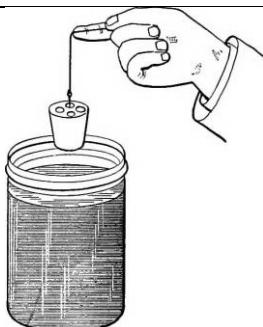
19	<p>We know that the earth attracts every object with a certain force and this force depends on the mass (m) of the object and the acceleration due to the gravity (g). The weight of an object is the force with which it is attracted towards the earth. Mathematically</p> $W = m \times g$ <p>Where, W= weight of object m= mass of object g= acceleration due to the gravitational force</p> <p>As the weight of an object is the force with which it is attracted towards the earth, the SI unit of weight is the same as that of force, that is, Newton (N). The weight is a force acting vertically downwards; it has both magnitude and direction. We have learnt that the value of g is constant at a given place. Therefore, at a given place, the weight of an object is directly proportional to the mass, say m, of the object, that is, $W \propto m$. It is due to this reason that at a given place, we can use the weight of an object as a measure of its mass.</p> <p>Answer the following questions.</p> <p>a) Whether weight is scalar quantity or vector quantity? Justify your answer.</p> <p>b) Differentiate between mass and weight</p> <p>c) Unit of acceleration due to the gravity (g) is.....</p>	4
20		4
	<p>Archimedes' principle, stated as follows: When a body is immersed fully or partially in a fluid, it experiences an upward force that is equal to the weight of the fluid displaced by it. The upward force is known as up thrust or buoyant force. In fact, all objects experience a force of buoyancy when they are immersed in a fluid. The magnitude of this buoyant force depends on the density of the fluid. Objects having density less than that of the liquid in which they are immersed float on the surface of the liquid. If the density of the object is more than the density of the liquid in which</p>	

it is immersed then it sinks in the liquid. Hence the body will float or sink depending upon the difference between density of body and fluid.

a) State Archimedes' principle.

b) Why does a cube of plastic released deep down under the water come up to the surface of water?

c) Name the force experienced on a body which is immersed in liquid

ANSWER KEY CHAPTER- 9 GRAVITATION

Q NO	SECTION A	MARKS
1	(c)	1
2	(c)	1
3	(a)	1
4	(b)	1
5	(a)	1
6	(b)	1
7	(a)	1
8	(c)	1
	SECTION B	
9	<p>The acceleration due to gravity does not depend upon the mass of the stone or body.</p> <p>Both the bodies fall with the same acceleration towards the surface of the earth.</p> <p>Thus a big stone will fall with the same acceleration as a small stone.</p> <p>So, both the stones will reach the ground at the same time when dropped simultaneously.</p>	2
10	<p>The universal law of gravitation was able to explain successfully</p> <ul style="list-style-type: none"> • the force that binds us to the earth. • the motion of the moon around the earth. • the motion of planets around the sun. • the tides due to the moon and the sun 	2
11	<p>The acceleration due to gravity is more at the poles than at the equator.</p> <p>The time taken for a body is less if the acceleration due to gravity is more when the initial velocities and the distance travelled are the same . So, when dropped from the same height a body reaches the ground quicker at the poles than at the equator.</p>	2

12	<p>Weight, $W = mg$, $m = W/g$, $m = 9.8/9.8 = 1 \text{ kg}$ So, acceleration = Force / Mass = $20/1 = 20 \text{ m/s}^2$</p>	2
13	<p>A bag with a small string is difficult to hold. This is because the thin strap has a small surface area. Pressure is inversely proportional to the area on which the force acts. It can be said that these thin strings exert greater pressure on the student's shoulder who is holding the bag</p>	2
SECTION C		
14	<p>Two forces act on the object's surface when placed on the water surface</p> <p>. These are weight and upthrust. The weight acts vertically downwards and the upthrust works vertically upwards. Based on these two forces, the object will either float or sink.</p> <p>If the weight is greater, the object will sink. The object will float on the water's surface if the upthrust is more than the weight.</p>	3
15	<p>Here, initial velocity, $u = 0$ Time taken to reach the ground, $t = 4 \text{ s}$ Acceleration, $a = g = 9.8 \text{ m/s}^2$ Height of the building, $h = ?$ $h = ut + \frac{1}{2}gt^2$ $= 0 + \frac{1}{2}gt^2$ $= \frac{1}{2} \times 9.8 \times 4^2$ $= 78.4 \text{ m}$</p>	3
16	<p>$h = 10 \text{ m}$,</p> <p>$g = 20 \text{ m/s}^2$</p> <p>$v^2 = u^2 + 2gh$</p> <p>$v^2 = 0 + 2 \times 20 \times 10 = 400$</p> <p>$v = 20 \text{ m/s}$</p> <p>$v = u + gt$</p> <p>$20 = 0 + 20t$</p> <p>$t = 20/20 = 1 \text{ sec}$</p>	3
SECTION D		

17	<p>(a) The pressure is the thrust per unit area of a surface. The SI unit of pressure is pascal.</p> <p>(b) It is given that mass = $M = 30\text{kg}$</p> <p>Acceleration due to gravity = 10 m/s^2</p> <p>Area = $A = 20\text{ cm} \times 15\text{ cm} = 0.2 \times 0.15\text{ m} = 0.03\text{ m}^2$</p> <p>Thrust = $M \times g = 30\text{ kg} \times 10\text{ m/s}^2 = 300\text{ N}$</p> <p>Pressure = Thrust / Area = $300/0.03 = 104\text{ Pascal}$</p> <p>(c) When we stand on the ground, we exert pressure. This pressure is exerted more when we stand on one foot as all the weight is exerted on the area of one foot only, so the pressure increases because the pre</p>	5 1+2+2
18	<p>a) Even when the metallic bar is taken to the equator, there will be no change in mass, and it will remain constant everywhere</p> <p>(b) When the bar is brought to the equator, its weight will decrease. This is due to lower value of 'g' at the equator as compared to the poles.</p> <p>(c) All objects will move in a straight line with uniform velocity if there is no acceleration due to gravity</p> <p>(d) The universal gravitational constant 'G' equals the force between the two unit masses separated by unit distance. Its value of $6.67 \times 10^{-11}\text{ N m}^2/\text{kg}^2$ is constant at every point. It has a minimal value.</p> <p>Acceleration due to gravity 'g' is equal to the acceleration experienced by a body of any mass. It has a large magnitude which changes from point to point.</p> <p>(e) Derivation. (refer NCERT text book)</p>	5
SECTION E		
19	<p>a) Weight is vector quantity as it has magnitude as well as direction which is always towards centre of a earth.</p> <p>b) Difference between mass and weight (any 2)</p> <p>c) m/s^2</p>	4 2+1+1
20	<p>a) Archimedes' principle, stated as follows: When a body is immersed fully or partially in a fluid, it experiences an upward force that is equal to the weight of the fluid displaced by it.</p> <p>b) because it has less density than that of water also it experiences upward buoyancy force on it due to liquid.</p> <p>c) buoyant force.</p>	4 2+1+1

CHAPTER: 10 WORK & ENERGY

Q.No	SECTION A	Marks
1	Which of these, pair of activities form examples of scientific work done? (i) Standing at a bus stop with a load of 5kg rice bag on the head for 10 minutes (ii) Walking to home with the school bag on the shoulder. (iii) Sitting on a chair and reading a Science text book. (iv) Climbing stairs to class from ground in ground a) I & iv b) I & iii c) ii & iii d) ii & iv	1
2	In case of positive work, the angle between the force and displacement is (a) 0^0 (b) 45^0 (c) 90^0 (d) 180^0	1
3	A body of mass m is falling from a height h. After it has fallen $\frac{1}{4}$ of height, it will possess (a) only potential energy (b) only kinetic energy (c) half potential and half kinetic energy (d) $\frac{1}{4}$ kinetic energy and $\frac{3}{4}$ potential energy	1
4	The kinetic energy possessed by an object of mass 5kg moving with a velocity of 10m/ s is 250J. What is the maximum amount of work that can be done by the object? (a) 50J (b) 15 J (c) 250J (d) 1250J	1
5	An object of mass, 'm' and moving with a uniform velocity, 'v', if its velocity is doubled, kinetic energy would be (a) $\frac{1}{2} mv^2$ (b) mv^2 (c) $2mv^2$ (d) $4mv^2$	1
6	A machine completes a work of 200 joule in 10 second. What is its power? (a) 20 watt (b) 210 watt (c) 5 watt (d) 2000 watt	1
ASSERTION /REASON		
7	Assertion: An arrow released from a stretched string of a bow travels a distance in the forward direction. Reason : The energy possessed by a body due to its change in its position or shape is called potential energy.	1
8	Assertion:. A person standing for a few minutes with a heavy load on the head does not do any work. Reason : Two conditions need to be satisfied for work to be done: (i) a force should act on an object, and (ii) the object must be displaced.	1
SECTION B		
9	A pair of bullocks exerts a force of 200 N on a plough. The field being ploughed is 10 m long. How much work is done in ploughing the length of the field? Express it in Joules and Kilo Joules.	2
10	An object of mass 20kg is moving with a uniform velocity of 5 m s^{-1} . What is the kinetic energy possessed by the object?	2
11	Mass of the car is 2000 kg? Calculate the work to be done to increase the velocity of the car from 18 km h^{-1} to 72 km h^{-1} .	2
12	1.Can any object have mechanical energy even if its momentum is zero? justify. 2.Can any object have momentum even if its mechanical energy is zero? justify.	2
13	Define the following	2

kinetic energy in each case. (For simplifying the calculations, take the value of g as 10 m s^{-2} .)

	Potential energy(mgh)	Kinetic energy($\frac{1}{2}mv^2$)	Total mechanical energy(mgh)+ ($\frac{1}{2}mv^2$)
4			
3			
2			
1			
Just touching ground			

2 Interpret the trend in the changes in case of potential energy, kinetic energy and total mechanical energy

3. Which law can be explained based on this data and state the law

ANSWER KEY CHAPTER:10 WORK & ENERGY

Q.N	SECTION A	Marks
1	d	1
2	a	1
3	d	1
4	c	1
5	c	1
6	a	1
	ASSERTION /REASON	
7	a, both A and R are correct and R is the correct explanation of A	1
8	a, both A and R are correct and R is the correct explanation of A	1
	SECTION B	
9	$F = 200\text{N}$ $s = 10 \text{ m}$ $W = F \times s$ $= 200\text{N} \times 10 \text{ m} = 2000\text{J} = 2\text{kJ}$	2
10	$m = 20 \text{ kg}$ $v = 5 \text{ m/s}$ $KE = \frac{1}{2} mv^2$ $= \frac{1}{2} \times 20 \times 5 \times 5$ $= 250\text{J}$	2

11	<p>Mass of car ,m = 2000kg Initial velocity ,u = 18km/h = $18 \times \frac{5}{18} = 5$ m/s. Initial kinetic energy , = $\frac{1}{2} mu^2 = \frac{1}{2} \times 2000 \times 5 \times 5 = 25000J$ (½) Final velocity , v = 72km/h = $72 \times \frac{5}{18} = 20$m/s Final kinetic energy = $\frac{1}{2} mv^2 = \frac{1}{2} \times 2000 \times 20 \times 20 = 400000J$ (½)</p> <p>Work done to change velocity from 18km/h to72km/h = change in kinetic energy Change in kinetic energy = Final kinetic energy – initial kinetic energy = $\frac{1}{2} mv^2 - \frac{1}{2} mu^2$ (½) = $400000 - 25000 = 375000J$ = $375kJ$ (½)</p>	2
12	<p>1.Yes, mechanical energy comprises both potential energy and kinetic energy. Momentum is zero which means velocity is zero. Hence, there is no kinetic energy but the object may possess potential energy. 2.No. Since mechanical energy is zero, there is no potential energy and no kinetic energy. Kinetic energy being zero, velocity is zero. Hence, there will be no momentum</p>	2
13	<p>1.One joule is the amount of work done on an object when a force of 1 N displaces it by 1 m along the line of action of the force (1) 2. 1 watt is the power of an agent, which does work at the rate of 1 joule per second (1)</p>	2
SECTION C		
14	<p>Consider an object of mass, m moving with a uniform velocity, u.</p> <p>Let it now be displaced through a distance s when a constant force, F acts on it in the direction of its displacement. The work done, W is F s. (½) The work done on the object will cause a change in its velocity. Let its velocity change from u to v. Let a be the acceleration produced.</p> <p>. The relation connecting the initial velocity (u) and final velocity (v) of an object moving with a uniform acceleration a, and the displacement, s is $v^2 - u^2 = 2a s$ (½)</p> <p>This gives $s = \frac{v^2 - u^2}{2a}$</p> <p>we know $F = m a$. (½)</p> <p>Thus, using we can write the work done by the force, F as $m \times a \times s$</p> <p>$W = m a \times \frac{v^2 - u^2}{2a}$ Ie $W = \frac{1}{2} \times m \times (v^2 - u^2)$ (½)</p> <p>If the object is starting from its stationary position, that is, u = 0, then</p> <p>$W = \frac{1}{2} \times m \times v^2$ (½)</p>	3

The work done is equal to the change in the kinetic energy of an object.
 If $u = 0$, the work done will be $\frac{1}{2} m v^2$.

Thus, the kinetic energy possessed by an object of mass, m and moving with a uniform velocity, v is

$$KE = \frac{1}{2} m v^2 \text{ . (}\frac{1}{2}\text{)}$$

15 1. Consider an object of mass, m . Let it be raised through a height, h from the ground.
 The minimum force required to raise the object is equal to the weight of the object, mg . ($\frac{1}{2}$)
 The object gains energy equal to the work done on it.
 Let the work done on the object against gravity be W .
 That is, work done,
 $W = \text{force} \times \text{displacement} = mg \times h = mgh$ ($\frac{1}{2}$)
 Since work done on the object is equal to mgh , an energy equal to mgh units is gained by the object.
 This is the potential energy (PE) of the object. $PE = mgh$ ($\frac{1}{2}$)



1.

Figure shows a case where a block is raised from position A to B by taking two different paths.
 if the height $AB = h$.
 In both the situations the work done on the object is mgh .

The work done by gravity depends on the difference in vertical heights of the initial and final positions of the object and not on the path along which the object is moved

16	<table border="1"> <thead> <tr> <th>OBJECT X</th> <th>OBJECT Y</th> </tr> </thead> <tbody> <tr> <td>Momentum = p_X</td> <td>Momentum = p_Y</td> </tr> <tr> <td>Mass = m_X (lighter object)</td> <td>Mass = m_Y (heavier object)</td> </tr> <tr> <td colspan="2" style="text-align: center;">$p_X = p_Y$, ie $m_X v_X = m_Y v_Y$, therefore $m_X < m_Y$ ie $v_X > v_Y$</td> </tr> <tr> <td>$KE_X = \frac{1}{2} m_X v_X^2 = \frac{1}{2} m_X v_X \times v_X$</td> <td>$KEY = \frac{1}{2} m_Y v_Y^2 = \frac{1}{2} m_Y v_Y \times v_Y$</td> </tr> <tr> <td>$= \frac{1}{2} (m_X v_X) \times v_X$</td> <td>$= \frac{1}{2} (m_Y v_Y) \times v_Y$</td> </tr> <tr> <td>$= \frac{1}{2} p_X \times v_X$ ($m_X v_X = p_X$)</td> <td>$= \frac{1}{2} p_Y \times v_Y$ ($m_Y v_Y = p_Y$)</td> </tr> <tr> <td colspan="2" style="text-align: center;">ie $KE_X / KEY = \frac{1}{2} p_X \times v_X / \frac{1}{2} p_Y \times v_Y$ ie $KE_X / KEY = v_X / v_Y$</td> </tr> </tbody> </table>	OBJECT X	OBJECT Y	Momentum = p_X	Momentum = p_Y	Mass = m_X (lighter object)	Mass = m_Y (heavier object)	$p_X = p_Y$, ie $m_X v_X = m_Y v_Y$, therefore $m_X < m_Y$ ie $v_X > v_Y$		$KE_X = \frac{1}{2} m_X v_X^2 = \frac{1}{2} m_X v_X \times v_X$	$KEY = \frac{1}{2} m_Y v_Y^2 = \frac{1}{2} m_Y v_Y \times v_Y$	$= \frac{1}{2} (m_X v_X) \times v_X$	$= \frac{1}{2} (m_Y v_Y) \times v_Y$	$= \frac{1}{2} p_X \times v_X$ ($m_X v_X = p_X$)	$= \frac{1}{2} p_Y \times v_Y$ ($m_Y v_Y = p_Y$)	ie $KE_X / KEY = \frac{1}{2} p_X \times v_X / \frac{1}{2} p_Y \times v_Y$ ie $KE_X / KEY = v_X / v_Y$		3
OBJECT X	OBJECT Y																	
Momentum = p_X	Momentum = p_Y																	
Mass = m_X (lighter object)	Mass = m_Y (heavier object)																	
$p_X = p_Y$, ie $m_X v_X = m_Y v_Y$, therefore $m_X < m_Y$ ie $v_X > v_Y$																		
$KE_X = \frac{1}{2} m_X v_X^2 = \frac{1}{2} m_X v_X \times v_X$	$KEY = \frac{1}{2} m_Y v_Y^2 = \frac{1}{2} m_Y v_Y \times v_Y$																	
$= \frac{1}{2} (m_X v_X) \times v_X$	$= \frac{1}{2} (m_Y v_Y) \times v_Y$																	
$= \frac{1}{2} p_X \times v_X$ ($m_X v_X = p_X$)	$= \frac{1}{2} p_Y \times v_Y$ ($m_Y v_Y = p_Y$)																	
ie $KE_X / KEY = \frac{1}{2} p_X \times v_X / \frac{1}{2} p_Y \times v_Y$ ie $KE_X / KEY = v_X / v_Y$																		

Since $v_X > v_Y$, then $KE_X > KE_Y$

SECTION D

17	<p>1 Law of conservation of energy states that , energy can only be converted from one form to another; it can neither be created or destroyed. The total energy before and after the transformation remains the same. The law of conservation of energy is valid in all situations and for all kinds of transformations. (1)</p> <p>Proof: Let an object of mass, m be made to fall freely from a height, h.</p> <p>At the start, the potential energy is mgh and kinetic energy is zero.</p> <p>Kinetic energy is zero because its velocity is zero. The total energy of the object is thus mgh. (1)</p> <p>As it falls, its potential energy will change into kinetic energy. If v is the velocity of the object at a given instant, the kinetic energy would be $\frac{1}{2}mv^2$. (1)</p> <p>As the fall of the object continues, the potential energy would decrease while the kinetic energy would increase. When the object is about to reach the ground, $h = 0$ and v will be the highest.</p> <p>Therefore, the kinetic energy would be the largest and potential energy the least. However, the sum of the potential energy and kinetic energy of the object would be the same at all points.</p> <p>That is, potential energy + kinetic energy = constant (1)</p> <p>$mgh + \frac{1}{2} mv^2 = \text{constant}$</p> <p>The sum of kinetic energy and potential energy of an object is its total mechanical energy.</p> <p>We find that during the free fall of the object, the decrease in potential energy, at any point in its path, appears as an equal amount of increase in kinetic energy.</p> <p>There is thus a continual transformation of gravitational potential energy into kinetic energy. (1)</p>	5
18	<p>1 (a) $F = m \times g$ $m = 250 \text{ kg}$ $g = 10 \text{ m s}^{-2}$ $F = 250 \times 10 = 2500 \text{ N}$ (1) $s = 1 \text{ m}$</p> <p>$W = F.s = 2500 \text{ N} \times 1 \text{ m} = 2500 \text{ J}$ (1)</p>	5

b.zero; as the box does not move at all, while holding it. (1)

c.In order to hold the box, men are applying a force which is opposite and equal to the gravitational force acting on the box. While applying the force, muscular effort is involved. So they feel tired. (1)

2.Initial velocity of rocket= v

Initial kinetic energy = $\frac{1}{2} mv^2$

Velocity tripled, Final velocity = 3v

Final kinetic energy= $\frac{1}{2} \times m \times (3v)^2 = 9 \times \frac{1}{2} mv^2$ (1/2)

Therefore kinetic energy increases 9 times (1/2)

SECTION E

19

1.a. no work is done since force and displacement are not involved (1/2)
b. Work is done since force and displacement are involved (1/2)

4

0. Si unit of work- joule (J) (1/2)
SI unit of power: watt (w) (1/2)

3.F = 5 N

s = (2 km + 100m+3 km) = (2000m+100m+3000m)=5100m

(Man takes one and a half round , but displacement is 100m only) (1)

W = F x s

= 5 N x 5100 =25500J = 25.5kJ (1)

20

	Potential energy(mgh)	Kinetic energy($\frac{1}{2}mv^2$)	Total mechanical energy(mgh)+ ($\frac{1}{2}mv^2$)
4	800	0	800
3	600	200	800
2	400	400	800
1	200	600	800
Just touching ground	0	800	800

(completing table 1 mark)

2.Potential energy decreases with the decrease in height

Kinetic energy increases with the increase in distance travelled









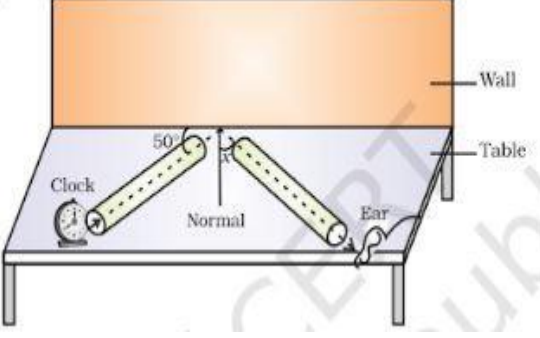

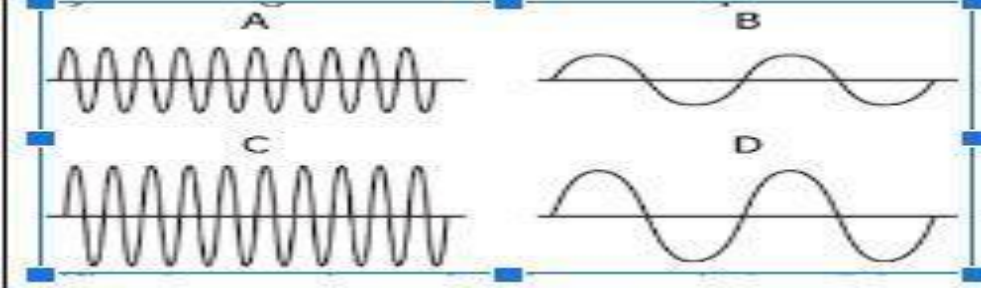

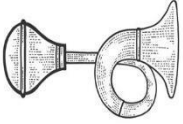
Total mechanical energy remains same (1)

3.Law of conservation of energy : According to the law of conservation of energy, energy can only be transformed from one form to another; it can neither be created nor destroyed. The total energy before and after the transformation always remains constant. (1+!)

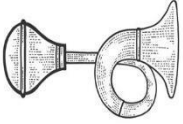
4

CHAPTER-11 : SOUND

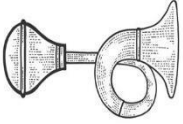
Q.No	SECTION A	Marks															
1	<p>Following table shows the lower and upper limit of hearing range of Four common tropical animals. Find the one which can hear the infrasound</p> <table border="1" style="margin: 10px auto; border-collapse: collapse;"> <thead> <tr> <th style="padding: 5px;">animal</th> <th style="padding: 5px;">Lower limit</th> <th style="padding: 5px;">Upper limit</th> </tr> </thead> <tbody> <tr> <td style="padding: 5px;">Mouse</td> <td style="padding: 5px;">1×10^3 Hz</td> <td style="padding: 5px;">100×10^3 Hz</td> </tr> <tr> <td style="padding: 5px;">Cat</td> <td style="padding: 5px;">45Hz</td> <td style="padding: 5px;">45×10^3 Hz</td> </tr> <tr> <td style="padding: 5px;">Dog</td> <td style="padding: 5px;">50Hz</td> <td style="padding: 5px;">65×10^3 Hz</td> </tr> <tr> <td style="padding: 5px;">Elephant</td> <td style="padding: 5px;">5Hz</td> <td style="padding: 5px;">12×10^3 Hz</td> </tr> </tbody> </table> <p style="text-align: center; margin-top: 10px;">. Mouse b) Cat c) Dog d) Elephant</p>	animal	Lower limit	Upper limit	Mouse	1×10^3 Hz	100×10^3 Hz	Cat	45Hz	45×10^3 Hz	Dog	50Hz	65×10^3 Hz	Elephant	5Hz	12×10^3 Hz	1
animal	Lower limit	Upper limit															
Mouse	1×10^3 Hz	100×10^3 Hz															
Cat	45Hz	45×10^3 Hz															
Dog	50Hz	65×10^3 Hz															
Elephant	5Hz	12×10^3 Hz															
2	<div style="text-align: center;">  </div> <p>Observe the diagram showing reflection of sound. Which statement is correct</p> <ol style="list-style-type: none"> a. Angle of incidence is 50° and angle of reflection is also 50° b. Angle X represents angle of reflection and is equal to 50° c. Angle of incidence is equal to 40° and angle of reflection is 50° d. Angle X represents angle of reflection, which equal to 40° because angle of incidence is 40° 	1															

<p>3</p>	 <p>Figure shows sound waves with different frequencies and wavelengths. Which sound has the highest frequency and which lowest amplitude</p> <p>. C with highest frequency and D with lowest amplitude</p> <p>a. A with highest frequency and B with lowest amplitude</p> <p>b. A with highest frequency and D with lowest amplitude</p> <p>c. C with highest frequency and B with lowest amplitude</p>	<p>1</p>				
<p>4</p>	<p>Identify instrument which does not work on multiple reflection of sound</p> <table border="1" data-bbox="308 1131 1238 1429"> <tr> <td data-bbox="308 1131 539 1429">  MEGAPHONE </td> <td data-bbox="539 1131 770 1429">  HORN </td> <td data-bbox="770 1131 986 1429">  ENDOSCOPE </td> <td data-bbox="986 1131 1238 1429">  STETHOSCOPE </td> </tr> </table> <p>. Megaphone b) horn c) endoscope d) stethoscope</p>	 MEGAPHONE	 HORN	 ENDOSCOPE	 STETHOSCOPE	<p>1</p>
 MEGAPHONE	 HORN	 ENDOSCOPE	 STETHOSCOPE			
<p>5</p>	<p>An object moving at a speed greater than the speed of sound is said to be in</p> <p>(a) infrasonic speed</p> <p>(b) sonic speed</p> <p>(c) ultrasonic speed</p> <p>(d) supersonic speed</p>	<p>1</p>				

6

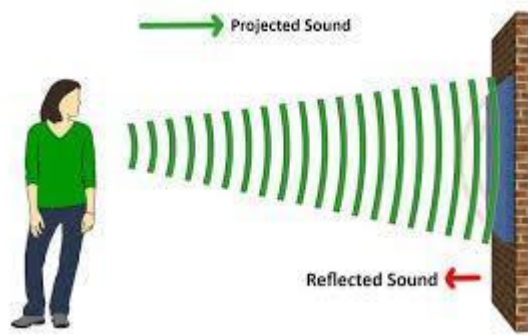

1

If X is the distance between the person and the wall and Y is the distance between wall and the person, which statement is correct, for no echo condition

- a) $X > Y$ b) $X = 17\text{m} \ \& \ Y = 34\text{m}$ c) $X + Y = 34\text{m}$
 d) $X \leq 17\text{m}, Y \leq 17\text{m}$ and $X + Y \leq 34\text{m}$

Question number 7 and 8 consists of two statements, namely, Assertion (A) and Reason (R).

Select the correct answer from the following

- (a) Both Assertion (A) and Reason (R) are the true and Reason (R) is a correct explanation of Assertion (A).
 (b) Both Assertion (A) and Reason (R) are true but Reason (R) is not a correct explanation of Assertion (A).
 (c) Assertion (A) is true and Reason (R) is false.
 (d) Assertion (A) is false and Reason (R) is true

7

Assertion: Bats fly in dark nights by emitting and detecting reflections of ultrasonic sounds.

Reason: Humans are not able to hear the high-pitched ultrasonic squeaks of bats.

1

8

Assertion: Some animals become alert and exhibit unusual behaviours, during earthquakes.

1

	Reason : Seismic waves have frequencies less than 20 Hz, thus they are infrasonic waves	
	SECTION B	
9	Illustrate how ultrasound can be used to detect flaws in metallic blocks.	2
10	Shanu , a class 9 boy, is scared of Thunder. Once, Shanu and his grandfather were alone at home , he heard a Sound produced by a thunderstorm ,10 s after the lightning was seen. Grandfather told him the thunder had not happened in the nearby area . Calculate the approximate distance of the thunder cloud. (Given speed of sound = 340 m s ⁻¹ .)	2
11	Define the term Amplitude and Frequency Represent graphically the following case: “Two sound waves having the same amplitude but different frequencies”?	2
12	Compare male voice and female voice based on their frequency and amplitude. Represent graphically the following case “Two sound waves having the same frequency but different amplitudes”.	2
13	Write an expression to relate speed, frequency and wavelength of sound. Represent graphically the following case “Two sound waves having different amplitudes and also different wavelengths”.	2
	SECTION C	
14	List three applications of ultrasonic sounds In the following fields .Research laboratories i.In industries	3
15	A rectangular park , on one side is bordered with a road and the opposite side with a wall of a building. A sound is produced by a cracker on the road. Is it possible for a child sitting at a point 5 m away from each side of the park. The Dimensions of the park is 10mx 10m.Justify your answer.	3
16	i)Explain how sound is produced by your school bell. ii)Why are sound waves called mechanical waves?	3

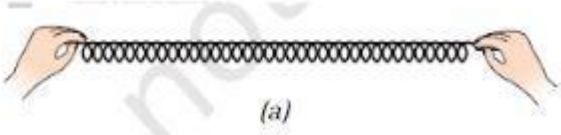
	iii) Suppose you and your friend are on the moon. Will you be able to hear any sound produced by your friend?	
	SECTION D	
17	Establish the relationship between speed of sound, its wavelength and frequency. If velocity of sound in air is 340 m s^{-1} , calculate .wavelength when frequency is 512 Hz. (ii) frequency when wavelength is 1.7 m	5
18	Draw a curve showing density or pressure variations with respect to distance for a disturbance produced by sound. Mark the position of compression and rarefaction on this curve. Also define wavelengths and time period using this curve	5
	SECTION E	
19	 <p>Take a slinky as shown in the figure. Ask your friend to hold one end. You hold the other end. Now stretch the slinky. Then give it a sharp push towards your friend.</p> <p>What do you notice?</p> <p>If you move your hand pushing and pulling the slinky alternatively, what will you observe?</p> <p>If you mark a dot on the slinky, you will observe that the dot on the slinky will move back and forth parallel to the direction of the propagation of the disturbance.</p> <ol style="list-style-type: none"> 1. Redraw the diagram of slinky to illustrate the observations and name the portion of slinky which come closer and the portion of slinky which are set apart. 2. Relate the direction of propagation of a sound wave with the disturbances. 3. Differentiate between longitudinal wave and transverse wave 	4
20		4

Ultrasound uses high-frequency sound waves to view internal organs and soft tissues. For this procedure, the doctors use a transducer, which transmits high-frequency sound waves. A handheld transducer is placed on the skin and a doctor moves it around to allow the sound waves to bounce off the soft tissues. An attached machine records the echoing waves, and translates them into pictures on a screen.

1. Out of the four investigative factors given, list a pair of characters, one which can be detected and other which cannot be detected by ultrasound examination of foetus: foetal sex determination, Foetal eye colour, Foetal body size, number of developing foetus.
2. Though X-rays can also be used to take the images of a developing foetus, doctors advise expectant mothers to avoid exposure to X-rays. Why abdominal X-rays are not recommended for pregnant women. Give two reasons?
3. The ultrasound waves travel through tissues at a speed of 1530 m/s. To form an image the ultrasound scanner should estimate the distance of the tissue from the probe. What measurement must the ultrasound machine make to calculate the distance. Justify your answer.

CHAPTER: SOUND ANSWER KEY

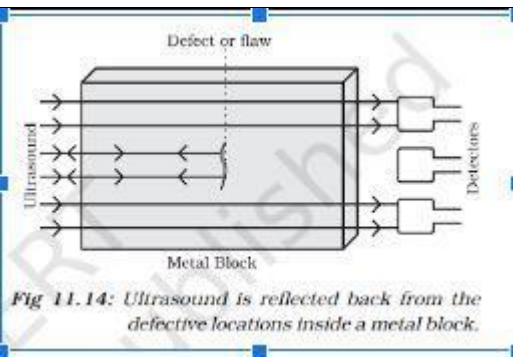
Q.N	SECTION A	Mark
1	d	1
2	d	1
3	d	1
4	c	1
5	d	1
6	d	1
7	b (both A and R are true, but R is not the correct explanation of A)	1
8	a (both A and R are true, and R is the correct explanation of A)	1
SECTION B		
9	 <p><i>Fig 11.14: Ultrasound is reflected back from the defective locations inside a metal block.</i></p> <p>Or description</p>	2
10	<p>Light travels faster than sound ($\frac{1}{2}$) Time taken to reach the sound of thunder= 10s Speed of sound= 340m/s Distance = speed x time</p>	2

$$= 10s \times 340m/s = 3400m = 3.4km \quad (\frac{1}{2}) + (\frac{1}{2})$$

Thunder happened 3.4 km away from Shanu's place.
Judgement of Grandfather was correct $(\frac{1}{2})$

11

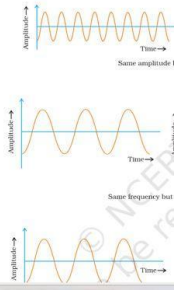

$$(\frac{1}{2}) + (\frac{1}{2})$$

Amplitude: Maximum distance to which a wave moves from its mean position $(\frac{1}{2})$

Frequency: Number of oscillations per second $(\frac{1}{2})$

2

12

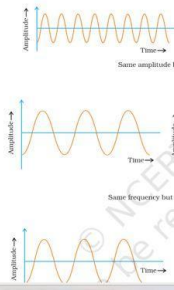

$$(\frac{1}{2}) + (\frac{1}{2})$$

	Frequency	Amplitude
Male voice	low	high
Female voice	high	low

$$(\frac{1}{2}) + (\frac{1}{2})$$

2

13

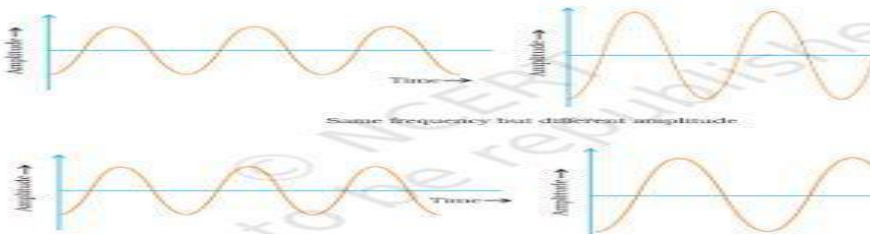

$$(\frac{1}{2}) + (\frac{1}{2})$$

$$v = \lambda \nu$$

That is, speed = wavelength \times frequency (1)

2

SECTION C

14

Ultrasound is generally used to clean parts located in hard-to-reach places, for example, spiral tube, odd shaped parts, electronic components, etc. $(\frac{1}{2})$
Objects to be cleaned are placed in a cleaning solution and ultrasonic waves are sent into the solution. $(\frac{1}{2})$

Due to the high frequency, the particles of dust, grease and dirt get detached and drop out. The objects thus get thoroughly cleaned $(\frac{1}{2})$

3

	<p>ii) Ultrasounds can be used to detect cracks and flaws in metal blocks in construction of big structures like buildings, bridges, machines and also scientific equipment. (½)</p> <p>Ultrasonic waves are allowed to pass through the metal block and detectors are used to detect the transmitted waves. (½)</p> <p>If there is even a small defect, the ultrasound gets reflected back indicating the presence of the flaw or defect(½)</p>	
15	<p>Echo is produced when sound travels 34 m (from the point of origin to reflecting surface and back the listener) within 0.1 s time gap. (1)</p> <p>Speed of sound = 340m/s Distance travelled by sound in 0.1 s = 340m/s x 0.1s = 34 m (1)</p> <p>The minimum distance travelled by the reflected sound wave for the distinctly listening the echo = 34/2 = 17 m</p> <p>Dimension of the park = 10m x 10m Since the distance of the child from the wall is 5 m , much smaller than the required distance to make a clear echo, No echo will be (1)formed.</p>	3
16	<p>i)When an object or school bell vibrates, it sets the particles of the medium around it vibrating. A particle of the medium in contact with the vibrating object is first displaced from its equilibrium position. It then exerts a force on the adjacent particle. As a result of which the adjacent particle gets displaced from its position of rest. After displacing the adjacent particle, the first particle comes back to its original position. This process continues in the medium till the sound reaches your ear. (½)+ (½)+ (½)</p> <p>ii) Sound waves are characterised by the motion of particles in the medium and are called mechanical waves (1)</p> <p>iii. No, as there is no medium sound is not propagated on moon's surface ((½)</p>	3
SECTION D		
17	<p>Derivation of formula $v = f \lambda$.</p> <p>The speed of sound is defined as the distance which a point on a wave, such as a compression or a rarefaction, travels per unit time.</p> <p>speed, $v = \text{distance} / \text{time}$ $= \lambda / T$</p> <p>Here λ is the wavelength of the sound wave. It is the distance travelled by the sound wave in one time period (T) of the wave. Thus, $v = \lambda f$ ($1/T = f$)</p> <p>or $v = \lambda f$ That is, speed = wavelength \times frequency.</p> <p>. $V = 340 \text{ m/s}$ $f = 512\text{Hz}$ $\lambda = ?$ $V = f \times \lambda$</p> <p>$\lambda = v/f = 340 / 512$</p> <p>$\lambda = 0.66 \text{ m.}$</p> <p>ii. $v = 340\text{m/s}$ $f = ?$ $\lambda = 1.7\text{m}$ $V = f \times \lambda$</p>	5

$$f = v/\lambda = 340 / 1.7 = 200\text{Hz}$$

18

5

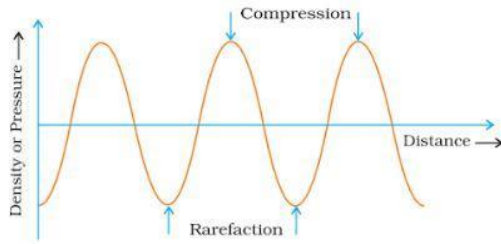

(labelling compressio1 mark, rarefaction 1 mark, diagram 1 mark)

Wavelength is the distance between two consecutive compressions or two consecutive rarefactions. (1)

Time period is the time taken to travel the distance between any two consecutive compressions or rarefactions from a fixed point. (1)

SECTION E

19

4

1.

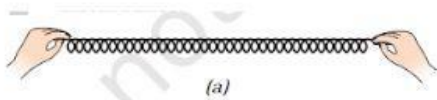

(1)

2. The direction of propagation of distance is parallel to the direction of propagation of wave (1)

3. a longitudinal wave is the wave in which the individual particles of the medium move parallel to the direction of wave propagation (1)

a transverse wave is the wave in which the individual particles of the medium move about their mean positions in a direction perpendicular to the direction of wave propagation (1)

20

4

1. a pair of characters
 ,one which can be detected - foetal sex determination,/, Foetal body size,/ number of developing foetus (½)
 which cannot be detected by ultrasound examination of foetus: , Foetal eye colour (½)

2. foetus may get harmful effect/ genetic change/ birth or developmental defect (½) + (½)

3. The ultrasound machine should measure the time to travel from probe or transducer to the tissue and reflect to reach the probe . (1)

The ultrasound machine will be able to produce the image if distance is measured.

Distance = Speed X time (1)

CHAPTER- 12 IMPROVEMENT OF FOOD RESOURCES

Q NO	SECTION A	MARKS
1	Which among the following is a method of fish farming? a. Pisciculture b. Poultry farming c. Sericulture d. Aviculture	1
2	Identify the component of soil which is not natural a. Minerals b. Fertilizer c. Air d. Water	1
3	Crop protection is the method of a Production of heavier and quality seeds b Harvesting good quality grains using machines c Storage of crops after drying in airtight containers d Keeping the crops safe from weeds, insects etc	1
4	Green revolution led to a. increased food production b. Increase animal feed (grass) production c. Increased production of milk d. Increased production of green leafy vegetables	1
5	Leghorn variety is related to a). Apiculture b . Dairy farming c. Pisciculture d. Poultry	1
6	Which of the following is an example of a Kharif crop? a. Wheat b. Mustard c. Rice	1

	d. Barley	
7	<p>ASSERTION: Sahiwal is a breed with long lactation period.</p> <p>REASON: Milk production depends on the duration of lactation period</p> <p>a. Both assertion (A) and reason (R) are true and reason (R) is the correct explanation of assertion (A).</p> <p>b. Both assertion (A) and reason (R) are true but reason (R) is not the correct explanation of assertion (A)</p> <p>c. Assertion (A) is true but reason (R) is false.</p> <p>d. Assertion (A) is false but reason (R) is true..</p>	
8	<p>ASSERTION: Fumigation is done by using chemicals</p> <p>REASON: Fumigation increase fertility of soil</p> <p>a. Both assertion (A) and reason (R) are true and reason (R) is the correct explanation of assertion (A).</p> <p>b. Both assertion (A) and reason (R) are true but reason (R) is not the correct explanation of assertion (A).</p> <p>c. Assertion (A) is true but reason (R) is false.</p> <p>d. Assertion (A) is false but reason (R) is true.</p>	1
	SECTION B	
9	Some of the nutrients are required by the crop in very small amounts. Identify the type of nutrient and give two examples	2
10	Evaluate how animal husbandry supports Indian economy	2
11	Manpreet bought an agricultural land which is elevated. Suggest any two methods by which he can prevent soil erosion?	2
12	What is Weeding? Mention any two methods to perform weeding.	2
13	Differentiate between milch and draught animals with one example	2
	SECTION C	
14	Compare the Use of Manure and Fertilizers in maintaining fertility of soil	3

15	List the desirable agronomic characteristics favouring Crop Improvements?	3
16	Increasing grain production alone solves the problem of malnutrition and hunger. Evaluate the statement giving valid reasons?	3
SECTION D		
17	Suresh wants to follow composite fish farming in his pond. What things should he keep in mind while selecting fish varieties for his farm? List any two advantages of composite fish farming	5
18	Explain different cropping patterns by evaluating their advantages	5
SECTION E		
19	<p>Beekeeping has been practiced for centuries and honey has been considered as a valuable and precious commodity that is used as medicine for traditional rituals, or as food. Beekeeping can be practiced effortlessly as an additional source of income for farmers in rural areas and has been successfully implemented in poverty-alleviating projects.</p> <p>a.</p> <p>b. Scientific name of rock bee is _____</p> <p>Why is pasturage important?</p> <p>c. List any two desirable characteristics of bee varieties which make them suitable for Honey Production?</p>	4
20	<p>Grain storage facilities storage and handling of variety of agricultural products, such as corn, soybeans, wheat, barley, rice, canola, flax, etc</p> <p>Use of traditional grain storage facilities such as cribs, improved rhombus, and brick bins are ineffective against many microbes already present in the grain before storage. While plastic bins reduce insect pests 'infestation, Purdue Improved crop storage bags and wooden silo were proved to be a viable management tool for preventing aflatoxin accumulation in storage and moisture migration.</p> <p>a</p> <p>b What are silos?</p> <p>Amita stored wheat in her storage box before proper drying and the grains got spoiled Evaluate possible reason behind this</p> <p>c Proper storage is as important as crop protection. Analyze any two factors which may be Responsible for the loss of grains during storage?</p>	4

ANSWER KEY CHAPTER- 12 IMPROVEMENT OF FOOD RESOURCES

Q NO	SECTION A	MARKS																		
1	a. Pisciculture	1																		
2	b. Fertilizer	1																		
3	d Keeping the crops safe from weeds, insects etc	1																		
4	a. increased food production	1																		
5	d. Poultry	1																		
6	c. Rice	1																		
7	d. Assertion (A) is false but reason (R) is true.																			
8	c. Assertion (A) is true but reason (R) is false.	1																		
	SECTION B																			
9	Micro nutrients Iron, cobalt, chromium, iodine, copper, zinc, molybdenum (any two)	1 1																		
10	It provides employment to a large number of farmer and thereby increases their living standards It helps in developing high yielding breeds of animals by cross breeding (or any other relevant point)	1+1																		
11	Terrace planting, planting more hedges (or any other)	1+1																		
12	Weeding is the removal of weeds Manual weeding, using weedicide	1 1																		
13	Milch breeds are milk–yielding animals eg cow draught breeds are working animals eg ox	1 1																		
	SECTION C																			
14	<table border="1" style="width: 100%; border-collapse: collapse;"> <thead> <tr> <th></th> <th style="text-align: center;">Manures</th> <th style="text-align: center;">Fertilisers</th> </tr> </thead> <tbody> <tr> <td style="text-align: center;">(i)</td> <td>They are not soluble in water. So they are not easily absorbed by the roots of the plants.</td> <td>They are soluble in water and are absorbed by the plants easily.</td> </tr> <tr> <td style="text-align: center;">(ii)</td> <td>These are inorganic substances.</td> <td>These are organic substances.</td> </tr> <tr> <td style="text-align: center;">(iii)</td> <td>Excessive use does not harm the soil texture, they provide humus to the soil.</td> <td>Excessive use can change the chemical composition of the soil and also pollutes water.</td> </tr> <tr> <td style="text-align: center;">(iv)</td> <td>They restore the soil texture and help in water retention.</td> <td>They may damage the soil texture.</td> </tr> <tr> <td style="text-align: center;">(v)</td> <td>These are nutrient specific.</td> <td>These are not nutrient specific.</td> </tr> </tbody> </table> <p>https://images.app.goo.gl/PCmYQD6E3XUjnH3g6</p>		Manures	Fertilisers	(i)	They are not soluble in water. So they are not easily absorbed by the roots of the plants.	They are soluble in water and are absorbed by the plants easily.	(ii)	These are inorganic substances.	These are organic substances.	(iii)	Excessive use does not harm the soil texture, they provide humus to the soil.	Excessive use can change the chemical composition of the soil and also pollutes water.	(iv)	They restore the soil texture and help in water retention.	They may damage the soil texture.	(v)	These are nutrient specific.	These are not nutrient specific.	3
	Manures	Fertilisers																		
(i)	They are not soluble in water. So they are not easily absorbed by the roots of the plants.	They are soluble in water and are absorbed by the plants easily.																		
(ii)	These are inorganic substances.	These are organic substances.																		
(iii)	Excessive use does not harm the soil texture, they provide humus to the soil.	Excessive use can change the chemical composition of the soil and also pollutes water.																		
(iv)	They restore the soil texture and help in water retention.	They may damage the soil texture.																		
(v)	These are nutrient specific.	These are not nutrient specific.																		
15	High Nutritional Content. ... Disease and Pest Resistance. ... High Crop Yield. ... Tallness and Profuse Branching for Fodder Crops. ... Dwarfness in Cereals.	3																		

	Response to Fertilizers. ... Adaptability to Varied Environmental Conditions.(any six)	
16	No, increasing grain production only for storage in warehouses cannot solve the problem of malnutrition and hunger Food security depends on both on availability and accessibility of food Free grains must be distributed to poor maintaining quality Grains only cannot solve the problem of malnutrition as it doesn't contain all nutrients in correct amount	1 1 1
	SECTION D	
17	composition of fish culture is the method of growing five or six different types of fish species together in a single fish pond. Catla -surface feeders, Rohu-middle zone feeders, Silver carp- phytoplankton Mrigal, Common carp-bottom feeders and Grass carp-weeds This system increases the fish yield fish species that have different food habitats do not compete for food among themselves.	1 2 1 1
18	1) mixed cropping- growing of two crops on a single piece of land. for 2) intercropping- growing of two crops in a definite pattern. 3) crop rotation- growing of different crops on a single piece of land. (any two advantages of each)	2 1/2 2 1/2
	SECTION E	
19	a. Apis dorsata It decides quality of honey More honey, sting less ,stay in hive for long, disease resistant(any two) b. c.	1 1 2
20	a used to store grains. b Moisture attracts microbes like bacteria, fungi. etc c biotic factors: Insects, rats, birds abiotic factors: moisture humidity, temperature	1 1 1+1

CLASS – VIII

COMPETENCY BASED TEST ITEMS

TABLE OF CONTENTS

S.NO.	NAME OF THE CHAPTER	PAGE NO.
1	CROP PRODUCTION AND MANAGEMENT	173
2	MICROORGANISMS: FRIEND AND FOE	178
3	COAL AND PETROLEUM	184
4	COMBUSTION AND FLAME	190
5	CONSERVATION OF PLANTS AND ANIMALS	196
6	REPRODUCTION IN ANIMALS	202
7	REACHING THE AGE OF ADOLESCENCE	209
8	FORCE AND PRESSURE	215
9	FRICTION	221
10	SOUND	227
11	CHEMICAL EFFECTS OF ELECTRIC CURRENT	233
12	SOME NATURAL PHENOMENA	238
13	LIGHT	243

CHAPTER 1- CROP PRODUCTION AND MANAGEMENT

Q NO	SECTION A	MARKS
1	Weeding involves removal of unwanted and uncultivated plants called a) crop b) granaries c) seeds d) weeds	1
2	If you are given a dry piece of land for cultivation, what will you do: a) Adequate watering to restore the moisture b) Tilled and ploughing for aeration c) manure is mixed to the soil d) all the above	1
3	Bhoojho wants to water his fruits plants, gardens and trees, he wants to adopt an irrigation system in which water is not wasted. Select the appropriate irrigation techniques a) Sprinkler system b) Drip system c) Pulley system d) Lever System	1
4	Improper use of fertilizers can cause: a) soil alkalinity and soil acidity b) soil acidity only and soil erosion c) soil acidity only d) soil erosion only	1
5	Good, healthy seeds when put in water then they: a) sink b) germinate c) float d) none of these	1
6	Which of the following statements is not true for organic manure? (a) It enhances the water holding capacity of the soil (b) It has a balance of all plant nutrients. (c) It provides humus to the soil. (d) It improves the texture of the soil	1
7	In the following questions, the Assertion and Reason have been put forward. Read the statements carefully and choose alternative from the following: (a) Both the Assertion and the Reason are correct and the Reason is the correct explanation of the Assertion . (b) The Assertion and the Reason are correct but the Reason is not the correct explanation of the Assertion . (c) Assertion is true but the Reason is false (d) The statement of the Assertion is false but the Reason is true. Assertion : Food is also obtained from animals for which animals are reared . This is called animal husbandry . Reason : Animals reared at home or in farms , have to be provided with proper food ,shelter and care.	1
8	Assertion : The grains are properly dried in the sun . Reason : This prevents the attack by insect pests,bacteria and fungi.	1
SECTION B		
9	A farmer wants to grow the crop of wheat ,arrange the following boxes of basic practices in proper order , which he will use for crop production	2

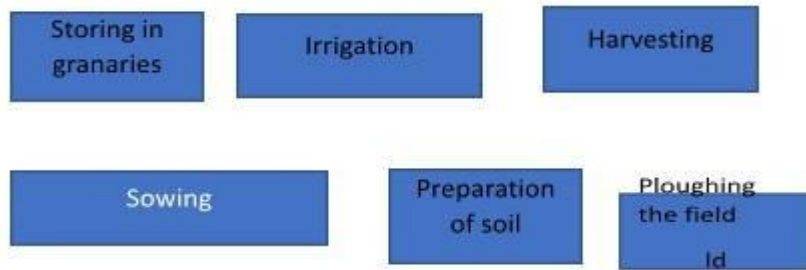

10	Why are few plants such as paddy and flowering plants grown in the nursery and when they grow into plantlets, they are transplanted in the field manually ?	2
11	It is strongly advised to wash fruits and vegetables before using them. Why?	2
12	Identify the following instruments used in agriculture and write their name and advantages.  <small>shutterstock.com · 2023191623</small>	2
13	If Mustard is sown in the Kharif season, what would happen? Discuss.	2
	SECTION C	
14	Continuous and excessive use of chemical fertilizers in the long run can affect the fertility of the soil. Justify.	3
15	What is harvesting? What are the different methods used for harvesting?	3
16	In a school, a field trip is arranged to see the crop field. Jaya noticed that along with wheat crops few unwanted plants are grown. What are these plants called? How these plants affect the growth of the crop. Name two methods to control them.	3
	SECTION D	
17	Storage of produce is important. Why? What precaution farmers should keep in mind before storing the freshly harvested produce. Briefly describe the methods involved in storing the produce.	5
18	Nowadays farmers are using modern agricultural implements over traditional ones. Discuss.	5
	SECTION E	

19

In the Fig below in glasses A,B and c gram seeds are grown



- i) glass A contains little amount of soil mixed with a little cow dung manure.
- ii) glass B contains the same amount of soil mixed with a urea.
- iii) glass C contains the same amount of soil without adding anything.
- a) Which glass shows the slowest growth and Why?
- b) Organic manure is considered better than fertilizers. Why?
- c) Name some chemical fertilizers

1
2
1

20

The supply of water to crops at different intervals is called irrigation. The time and frequency of irrigation varies from crop to crop, soil to soil and season to season. To maintain the moisture of the soil for healthy crop growth, fields have to be watered regularly.

- a) In summer, the frequency of watering is higher. Why?
- b) Device a strategy that will help a farmer to have a better yield in sandy soil.
- c)How much water does a plant body contain?

1
2
1

ANSWER KEY (CHAPTER 1- CROP PRODUCTION AND MANAGEMENT)

Q NO	SECTION A	MARKS
1	d) weeds	1
2	d) all the above	1
3	b) Drip system	1
4	b) soil alkalinity and soil acidity	1
5	c) sink	1
6	b) It has a balance of all plant's nutrients	1
7	a	1
8	a)	1
SECTION B		
9	i) Preparation of soil ii) Ploughing the field iii) sowing iv) irrigation v) Harvesting vi) Storing in granaries	2
10	It allows to plant the seedlings at the right spacing and select only healthy seedlings for the plants	2
11	Fruits and vegetables may contain many pesticides that can enter the body, causing serious health problems.	2
12	Plough. Any advantage	2
13	Mustard is a Rabi crop, so it is generally sown in the Winter season. it doesn't require much water, lack of optimum temperature and various other physical conditions. If sown in kharif season its production will decrease considerably.	2
SECTION C		
14	Continuous and excessive use of chemical fertilizers can change pH of soil, kill soil microorganism and reduce the organic matter and humus in the soil.	3
15	The cutting of the crop after it is mature. The different methods used for harvesting are Using a sickle and harvester.	3
16	These unwanted plants are called weed. Weeds compete with the main crop plant for air, water, sunlight and nutrients. Weeds are removed with the help of khurpi and by using weedicide.	3
SECTION D		
17	High moisture and high temperature favour development of insects and moulds that affect grain quality. Grains must be sun dried thoroughly. Two methods involved in storing the produce.	2 1 2
18	Any 5 advantages of using modern agriculture implements over traditional ones.	5
SECTION E		
19	a) Glass C .Reason b) Two advantage of manure over chemical fertilizers	1

	c) Urea, ammonium sulphate, Potash NPK	2 1
20	a) Increased rate of evaporation of water from the soil and leaves b)i) Growing crops suitable for sandy soil. ii) Using sprinkler irrigation system c) About 90%	1 2 1

CHAPTER 2- Microorganism: Friends and Foe

Q NO	SECTION A	MARKS
1	Some medicines obtained from microorganisms are applied to kill or stop the growth of disease causing microorganisms. Such medicines are called a) antibodies b) antibiotics c) antiseptics d) all the above	1
2	In Ram village malaria is spreading, select the preventive measure Ram would use to prevent disease: a) Consume properly cooked food b) Drink boiled drinking water c) Use mosquito net and repellents d) Keep the personal belongings of the patient away from those of the others	1
3	Paheli wants to know incorrect sentences about viruses? a) Viruses are microscopic. b) Reproduce only inside the cells of the host organism c) Virus do not respire, feed, excrete or move d) none of the above	1
4	Rhizobium found in root nodules of leguminous roots is an a) Atmospheric Carbon fixer b) Atmospheric Oxygen fixer c) Atmospheric Nitrogen fixer d) All of the above	1
5	Milk turned into curd by_____ ? a) yeast b) Bacteria c) Protozoa d) none of these	1
6	Deliberately injecting weak microbes into a healthy body and producing antibodies to fight against strong microbes is called a) Medication b) Antibiotics c) vaccination d) All of the above	1
	In the following questions, the Assertion and Reason have been put forward. Read the statements carefully and choose alternative from the following: (a) Both the Assertion and the Reason are correct and the Reason is the correct explanation of the Assertion . (b) The Assertion and the Reason are correct but the Reason is not the correct explanation of the Assertion . (c) Assertion is true but the Reason is false (d) The statement of the Assertion is false but the Reason is true.	1

7	Assertion: Food poisoning could be due to the consumption of food spoiled by some microorganisms. Reason: Microorganism that grow on food produce toxic substances.	
8	Assertion: Microorganisms can spoil food, clothing and leather. Reason: Some of the microorganisms cause diseases in human beings, plants and animals are called pathogens	1
SECTION B		
9	Differentiate between viruses and other microorganisms.	2
10	It is always suggested not to eat anything from street hawkers. Why?	2
11	Write short notes on (a) Protozoa (b) Alga	2
12	Jam, Jellies and squashes contain sugar as a preservative. Give reason.	2
13	Hari's mother added a little curd to warm milk to set curd for the next day .Why do you think Hari's mother added curd to the milk?	2
SECTION C		
14	Nitrogen is very important for the growth of plants.Explain how nitrogen cycle operates in the environment and draw a schematic diagram of nitrogen cycle.	3
15	What are antibiotics? What precautions must be taken while taking antibiotics?	3
16	Neha 's mother bought some raw mangoes, Neha wants to preserve these mangoes for a longer time. Answer as per questions asked below. a) Suggest the method of preservation her mother will use. b) Define the process. c) Identify the type of preservative used in our kitchen	3
SECTION D		
17	Observe the image below and answer the questions. 	5
Fig. 2.1		
https://schools.aglasem.com/60019/		
(a) Write the name of the disease.		

	(b) Name the causative agent of this disease? (c) How does the disease spread from one plant to another? (d) Name any two plant diseases and the microbes that cause them.	
18	Give reasons for the following. (a) Fresh milk is boiled before consumption while processed milk stored in packets can be consumed without boiling. (b) Raw vegetables and fruits are kept in refrigerators whereas jams and pickles can be kept outside. (c) Farmers prefer to grow beans and peas in nitrogen deficient soils.	5
SECTION E		
19	Microorganisms are used for various purposes. They are used in the preparation of curd, bread and cake ..Microorganisms have been used for the production of alcohol since ages. They are also used in cleaning up the environment. For example, the organic wastes (vegetable peels, remains of animals, faeces, etc.) a) Explain the process of doubling of flour after addition of yeast into it. b) Name some of the medicinal uses of microorganisms. c) Name any one microorganism which led to pandemic in recent times and suggest some preventive measures.	2 1 1
20	Paheli dug two pits, A and B, in her garden. In pit A, she put polythene bags, glass bottles and broken toys. In pit B, she dumped the plant waste. She then covered both the pits with soil for 1 month. Answer the following questions. a) What difference did she observe after a month in pit A and pit B? b) Suggest a method you will use to treat your kitchen waste. c) What are decomposers?	1 2 1

ANSWER KEY (CHAPTER 2– Microorganism: Friends and Foe)

Q NO	SECTION A	MARKS				
1	b) antibiotics	1				
2	c) Use mosquito net and repellents	1				
3	d) none of the above	1				
4	c) Atmospheric Nitrogen fixer	1				
5	b) Bacteria	1				
6	c) vaccination	1				
7	a)	1				
8	b)	1				
SECTION B						
9	<table border="1" style="width: 100%; border-collapse: collapse;"> <thead> <tr> <th style="width: 50%; text-align: center;">Viruses</th> <th style="width: 50%; text-align: center;">Other microbes</th> </tr> </thead> <tbody> <tr> <td style="vertical-align: top;">(i) They show the characteristics of living organisms or reproduce only by entering the host organisms.</td> <td style="vertical-align: top;">(i) They do not need to enter any host organism to reproduce or show any characteristics of life.</td> </tr> </tbody> </table>	Viruses	Other microbes	(i) They show the characteristics of living organisms or reproduce only by entering the host organisms.	(i) They do not need to enter any host organism to reproduce or show any characteristics of life.	2
Viruses	Other microbes					
(i) They show the characteristics of living organisms or reproduce only by entering the host organisms.	(i) They do not need to enter any host organism to reproduce or show any characteristics of life.					

	(ii) They are non-cellular microbes.	(ii) They are cellular microbes.	
10	Most street hawkers sell food items in an open area which always get contaminated with the dust and flies carrying germs with them. Such an unhygienic condition leads to spoilage of food which when consumed can lead to serious illness.		2
11	Protozoa: Protozoa are unicellular animals. Some are free-living, others are parasites. Several parasitic protozoans cause diseases in human beings, domestic animals and plants. For example, Plasmodium, a protozoan, causes malaria. Algae: Algae are green substances floating on the surface of a pond, lake, river, stagnant water, moist soil, stones. They tend to grow on wet surfaces. Therefore, they can synthesize their own food. They are found in water or in very moist places.		2
12	Sugar is used as a preservative in jams, jellies and squashes. Sugar reduces the moisture content which inhibits the growth of bacteria which spoil food.		2
13	Curd contains several microorganisms. Of these the bacterium, Lactobacillus promotes the formation of the curd.		2
SECTION C			
14	The nitrogen cycle is the biogeochemical cycle by which nitrogen is converted into multiple chemical forms as it circulates among atmospheric, terrestrial, and marine ecosystems. The conversion of nitrogen can be carried out through both biological and physical processes. Explanation Diagram		1 2
15	Antibiotics Are medicines produced by certain microorganisms to kill other disease-causing microorganisms. These medicines are commonly obtained from bacteria and fungi. Streptomycin, tetracycline, penicillin, etc. are common antibiotics. Precautions to be taken while using antibiotics: (i) Antibiotics should be taken under the supervision of a well-qualified doctor. (ii) Course (intake) of antibiotics should be completed as per the prescription given by the doctor. (iii) Antibiotics should be taken in the right amount and at the right time. A wrong dose of antibiotics makes the drug ineffective. Also, excessive consumption of drugs may kill the useful bacteria present in our body.		3
16	a) The method of preservation can be done using of oil, salt and vinegar		3

	<p>b) Food preservation is the technique to prevent food spoilage, food poisoning and microbial contamination in food.</p> <p>c) The type of preservatives used in our kitchen are common salt, sugar, oil and vinegar etc.</p>	
SECTION D		
17	<p>a) Yellow vein mosaic of bhindi</p> <p>b) Virus</p> <p>c) Mode of Transmission - Insect</p> <p>d) Citrus Canker – Bacteria , Rust of Wheat – Fungi</p>	<p>1</p> <p>1</p> <p>1</p> <p>2</p>
18	<p>(a) Fresh milk must be boiled in order to destroy any harmful microorganisms that may be present. While processed milk has been pasteurized, making it safe to consume straight. Pasteurized milk is boiled at 70 degrees Celsius and then suddenly cooled.</p> <p>(b) They're kept in the fridge because bacteria can't grow at low temperatures. Sugar and salt make jams and pickles resistant to microbial infection</p> <p>(c) Leguminous plants such as peas and beans have nitrogen-fixing bacteria called Rhizobium</p>	<p>2</p> <p>2</p> <p>1</p>
SECTION E		
19	<p>a) After adding yeast into the flour, the yeast reproduces rapidly and produces carbon dioxide during respiration. Bubbles of gas fill the dough and hence the volume of dough is doubled in size.</p> <p>b) Antibiotics and Vaccine .</p> <p>c) i) Coronavirus ii) Any of the preventive measure</p>	<p>1</p> <p>2</p> <p>1</p>
20	<p>a) Waste in pot B has been decomposed whereas waste in pot A did not undergo any change .</p> <p>b) Composting (explain)</p> <p>c) Microorganisms which can decompose dead organic waste of plants and animals.</p>	<p>1</p> <p>2</p> <p>1</p>

CHAPTER 3- COAL AND PETROLEUM

Q NO	SECTION A	MARKS
1	Compressed natural gas is green gas, due to its nature it is been used in a. Power generation b. Electric generators c. Solvent d. None of these	1
2	PCRA stands for a. Pollution control research association b. Petroleum conservation Research association c. Petroleum control research association d. Petrol, coal reserve association	1
3	Good quality of Roads shows development. In order to enhance the quality of roads identify the material used for road construction: (a) Peat (b) Bitumen (c) Lignite (d) Anthracite	1
4	Government from time to time is providing subsidy and encouraging solar panels to be installed, government decision can be justified on bases that sunlight is (a) exhaustible natural resource (b) Inexhaustible natural resource (c) exhaustible artificial resource (d) Inexhaustible artificial resource	1
5	Suhaas is an industrialist and recently got government permission to start Steel industry at Ramagundam, suggest him the product of coal which is a raw material for said industry from the following (a) Coal tar (b) Anthracite (c) Coke (d) Peat	1
6	Petroleum is separated by using the difference in (a) ignition temperatures (b) melting points (c) freezing points (d) boiling point.	1

7	<p>Q. no 7-8 are Assertion - Reasoning based questions. These consist of two statements – Assertion (A) and Reason (R). Answer these questions selecting the appropriate option given below:</p> <p>(a) Both A and R are true and R is the correct explanation of A (b) Both A and R are true and R is not the correct explanation of A (c) A is true but R is false (d) A is False but R is true</p> <p>7. Assertion: Fossil fuels are formed from dead and decaying matter. Reason: CNG is the best example of fossil fuel.</p>	1
8	<p>Assertion: Coke is a pure form of coal Reason: Coal gives away oxygen during burning.</p>	1
SECTION B		
9	A product of coal is a mixture of about 200 substances. Identify the product and write its uses in our daily life.	2
10	Differentiate between exhaustible and inexhaustible natural resources with examples	2
11	Write two uses of Paraffin wax.	2
12	Coal is considered as fossil fuel. Explain	2
13	What are petrochemicals?	2
SECTION C		
14	Burning of fossil fuels is a major cause of concern. Evaluate the statement.	3
15	<p>Illustrate the advantages CNG has over other fuels.</p> <p style="text-align: center;">OR</p> <p>List the uses of coal tar</p>	3
16	Madhu keenly heard her science teacher talking about petroleum products. She wants to prepare coal and natural gas in the laboratory from dead organisms. Is it possible for her? Justify logically and defend your answer.	3

SECTION D														
17	<p>(a). Sustainable development will lead to longevity of our future. Evaluate and draw your conclusion with respect to the importance of conservation of inexhaustible natural resources. (3m)</p> <p>(b). Recommend a list of alternate sources of energies which would keep our earth clean and green. (2m)</p>	5												
18	<p>(a). Give 3 tips by PCRA to save petrol/diesel while driving. (3m)</p> <p style="text-align: center;">OR</p> <p>Arrange the sequence of events in the formation of coal</p> <p>(b). Analyze the importance of black gold (2m)</p>	5												
SECTION E														
19	<p>III. CASE STUDY-BASED QUESTIONS: 1. This is a pie chart about energy sources in country Y in the year 2018. Examine it and answer the questions given alongside:</p> <div style="text-align: center;"> <table border="1" style="margin: 10px auto;"> <caption>Energy Sources in Country Y (2018)</caption> <thead> <tr> <th>Energy Source</th> <th>Percentage</th> </tr> </thead> <tbody> <tr> <td>Natural gas</td> <td>40%</td> </tr> <tr> <td>Petroleum</td> <td>33%</td> </tr> <tr> <td>Coal</td> <td>17%</td> </tr> <tr> <td>Nuclear electricity</td> <td>8%</td> </tr> <tr> <td>Renewables and others</td> <td>2%</td> </tr> </tbody> </table> </div> <p>(a) What percentage of fossil fuels did Country Y consume that year? (1M)</p> <p>(b) Do you find that renewable sources play an important role in the country? Why? (1M)</p> <p>(c) Mention the names of fossil fuels used by this country. (1M)</p> <p>(d) Which fossil fuel used by country Y is a clean fuel?(1M)</p>	Energy Source	Percentage	Natural gas	40%	Petroleum	33%	Coal	17%	Nuclear electricity	8%	Renewables and others	2%	4
Energy Source	Percentage													
Natural gas	40%													
Petroleum	33%													
Coal	17%													
Nuclear electricity	8%													
Renewables and others	2%													
20	<p>In the light of the availability of various resources in nature, natural resources can be broadly classified into two kinds- Inexhaustible and Exhaustible resources. Inexhaustible natural resources are present in unlimited quantities in nature and are not likely to be exhausted by human activities. Examples are sunlight, and air. Exhaustible resources are present in limited quantities in nature. They can be exhausted by human activities. Examples of these resources are forests, wildlife,</p>	4												

	<p>minerals, coal, petroleum, natural gas etc. some exhaustible natural resources like coal, petroleum and natural gas. These were formed from the dead remains of living organisms (fossils). So, these are all known as <i>fossil fuels</i>.</p> <p>(a) Assess the reason for sunlight being an inexhaustible source of energy and also formulate and recommend to make good use of this inexhaustible source.(1 m)</p> <p>(b) Justify as to why petroleum products are considered as fossil fuels. (2m)</p> <p>(c) Under which category of resource the wildlife can be placed.(1m)</p>	

ANSWER KEY (CHAPTER 3- COAL AND PETROLEUM)

Q NO	SECTION A	MARKS
1	a	1
2	b	1
3	b	1
4	b	1
5	b	1
6	d	1
7	b	1
8	c	1
SECTION B		
9	Coal tar and any two uses of it.	2
10	Any two differences with examples	2
11	Any two uses of paraffin wax.	2
12	Under high pressure and high temperature, dead plants got slowly converted to coal. As coal contains mainly carbon, the slow process of conversion of dead vegetation into coal is called carbonization.	2

13	Substances which are useful and obtained from petroleum and natural gas.	2
SECTION C		
14	When fossil fuels are burned, they release large amounts of carbon dioxide, a greenhouse gas, into the air. Greenhouse gases trap heat in our atmosphere, causing global warming.	3
15	<ul style="list-style-type: none"> • Green Fuel. Commonly referred to as the green fuel because of its lead and sulphur free character, CNG reduces harmful emissions. ... • Safe Fuel. The properties of CNG make it a safe fuel. ... • High auto ignition temperature. ... • Low operational cost. ... • Dual facility. ... • Increased life of oils. <p>Any three relevant points can be given marks.</p> <p style="text-align: center;">OR</p> <p>Coal tar is widely used to manufacture paints, perfumes, synthetic dyes, photographic material, drugs and explosives. It can be utilized to make insecticides and pesticides. Naphthalene balls that are commonly used to keep moths away are made from tar.</p>	3
16	No, their formation is a slow process and conditions for their formation cannot be created in the laboratory.	3
SECTION D		
17	<p>(a). Energy resources like coal, oil, and natural gas can cause pollution and medical complications. Conservation of energy ensures less carbon footprint and hence less pollution. Energy conservation minimizes carbon dioxide emissions into the atmosphere, lowering the chances of global warming. Any other relevant points can be considered. (3m)</p> <p>(b). Any relevant alternate source of energies like wind, solar etc. can be given marks. (2m)</p>	5
18	<p>(a). Any 3 relevant points can be given marks. (3m)</p> <p style="text-align: center;">OR</p>	5

	Marks can be allotted if formation of events is mentioned properly. (2m) (c) Any point indicating relevance of petroleum (1)	
SECTION E		
19	(a) 90 percent(1m) (b) No, because only 2 percent of the renewable resources were used. (1m) (c)Coal, petroleum and natural gas(1m) (d) Natural gas(1m)	4
20	(a) They are in unlimited supply. Sunlight and air are examples of inexhaustible natural resources. They will not get depleted with use. We can continue to utilize energy from the sun until the sun exists. more installation of the solar station /panel. Any other relevant answer may be awarded marks. (1m) (b) Over millions of years, heat and pressure from Earth's crust decomposed these organisms into one of the three main kinds of fuel: oil (also called petroleum), natural gas, or coal. These fuels are called fossil fuels, since they are formed from the remains of dead animals and plants. (2m) (c) Exhaustible natural resource(1m)	4

CHAPTER 4- Combustion and Flame

Q NO	SECTION A	MARKS
1	Fuels which are used for running vehicles? a. CNG b. Petrol c. Both (a) and (b) d. wood	1
2	Which of the following is the inexhaustible natural resource? a. Coal b. Petrol c. Diesel d. Sunlight	1
3	Which of the following are the non-combustible substances? a. Stone b. Wood c. Iron nail d. (a) and (c)	1
4	Spontaneous combustion is a. Substances burn rapidly to produce heat and light. b. Substances burst into flames, without the application of any apparent cause. c. Substances burn with heat and light forming large amounts of gas. d. Substances burn with the lowest temperature.	1
5	Substances that have very low ignition temperature are called a. Flammable substances b. Inflammable substances c. Non- combustible substances d. None of the above	1
6	Which of the following can take place if pressure is applied on the cracker? a. Combustion b. Rapid Combustion c. Explosion d. Spontaneous combustion	1
7	Assertion- Combustible substances are magnesium and charcoal. Reason- heat and light evolved after the process of chemical reaction between combustible substances and oxygen. a. Assertion and reason both are correct statements and reason is correct explanation for assertion. b. Assertion and reason both are correct statements and reason is not correct explanation for assertion. c. Assertion is a correct statement but reason is wrong statement. d. Assertion is a wrong statement but reason is correct statement.	1

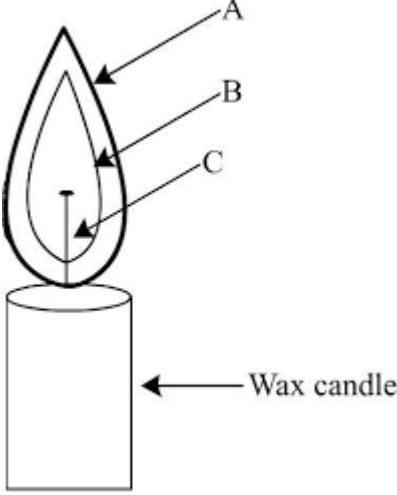
8	<p>Assertion – water can be used to control fire due to oil.</p> <p>Reason- water is commonly used to control fire.</p> <p>a. Assertion and reason both are correct statements and reason is correct explanation for assertion.</p> <p>b. Assertion and reason both are correct statements and reason is not correct explanation for assertion.</p> <p>c. Assertion is a correct statement but reason is wrong statement.</p> <p>d. Assertion is a wrong statement but reason is correct.</p>	1																				
SECTION B																						
9	Define inflammable substances. Give two examples.	2																				
10	Name two oxides produced by the burning of coal.	2																				
11	Why is it difficult to burn some substances whereas some substances catch fire easily?	2																				
12	What type of fire extinguishers are used at airports and petrol pumps?	2																				
13	Find combustible and non- combustible substances from the table given below.	2																				
	<table border="1"> <thead> <tr> <th>S. No</th> <th>Material</th> <th>Combustible</th> <th>Non- combustible</th> </tr> </thead> <tbody> <tr> <td>1</td> <td>Wood</td> <td></td> <td></td> </tr> <tr> <td>2</td> <td>Stone</td> <td></td> <td></td> </tr> <tr> <td>3</td> <td>Paper</td> <td></td> <td></td> </tr> <tr> <td>4</td> <td>Glass</td> <td></td> <td></td> </tr> </tbody> </table>	S. No	Material	Combustible	Non- combustible	1	Wood			2	Stone			3	Paper			4	Glass			
S. No	Material	Combustible	Non- combustible																			
1	Wood																					
2	Stone																					
3	Paper																					
4	Glass																					
SECTION C																						
14	 <p style="text-align: center;">https://images.app.goo.gl/5XXqFeJyDE8VfuAk7</p> <p>Label the different zones of candle flame in above diagram.</p>	3																				
15	<p>Give two examples of each fuel given in the following table.</p> <table border="1"> <thead> <tr> <th>S. No</th> <th>Fuel</th> <th>Examples</th> </tr> </thead> <tbody> <tr> <td>1</td> <td>Solid fuel</td> <td>(a) (b)</td> </tr> <tr> <td>2</td> <td>Liquid fuel</td> <td>(a) (b)</td> </tr> <tr> <td>3</td> <td>Gaseous fuel</td> <td>(a) (b)</td> </tr> </tbody> </table>	S. No	Fuel	Examples	1	Solid fuel	(a) (b)	2	Liquid fuel	(a) (b)	3	Gaseous fuel	(a) (b)	3								
S. No	Fuel	Examples																				
1	Solid fuel	(a) (b)																				
2	Liquid fuel	(a) (b)																				
3	Gaseous fuel	(a) (b)																				
16	Write any three Characteristics of ideal fuel.	3																				

SECTION D																																						
17	What is acid rain? How is it harmful to human beings as well as plants and animals on the land?	5																																				
18	Talk to people who use LPG at home. Find out what precautions they take in using LPG. Write any five precautions.	5																																				
SECTION E																																						
19	<p>Calorific value is the amount of heat energy released during the complete combustion of a unit mass of fuel. It is expressed in kJ/kg. What conclusion you will draw from the following data.</p> <table border="1"> <thead> <tr> <th>S. No</th> <th>Fuel</th> <th>Calorific Value (kJ/kg)</th> </tr> </thead> <tbody> <tr> <td>1.</td> <td>Cow dung cake</td> <td>6000-8000</td> </tr> <tr> <td>2.</td> <td>Wood</td> <td>17000-22000</td> </tr> <tr> <td>3.</td> <td>Coal</td> <td>25000-33000</td> </tr> <tr> <td>4.</td> <td>Petrol</td> <td>45000</td> </tr> <tr> <td>5.</td> <td>Kerosene</td> <td>45000</td> </tr> <tr> <td>6.</td> <td>Diesel</td> <td>45000</td> </tr> <tr> <td>7.</td> <td>Methane</td> <td>50000</td> </tr> <tr> <td>3.</td> <td>CNG</td> <td>50000</td> </tr> <tr> <td>9.</td> <td>LPG</td> <td>55000</td> </tr> <tr> <td>10.</td> <td>Biogas</td> <td>35000-40000</td> </tr> <tr> <td>11.</td> <td>Hydrogen</td> <td>150000</td> </tr> </tbody> </table> <p>Answer the following questions below.</p> <ol style="list-style-type: none"> Which of the fuel above mentioned table has highest calorific value? Which of the fuel above mentioned table has least calorific value? Find the calorific value of X, if 90,000 kJ heat was produced after 2kg of it was completely burnt. What is fuel efficiency? 	S. No	Fuel	Calorific Value (kJ/kg)	1.	Cow dung cake	6000-8000	2.	Wood	17000-22000	3.	Coal	25000-33000	4.	Petrol	45000	5.	Kerosene	45000	6.	Diesel	45000	7.	Methane	50000	3.	CNG	50000	9.	LPG	55000	10.	Biogas	35000-40000	11.	Hydrogen	150000	4
S. No	Fuel	Calorific Value (kJ/kg)																																				
1.	Cow dung cake	6000-8000																																				
2.	Wood	17000-22000																																				
3.	Coal	25000-33000																																				
4.	Petrol	45000																																				
5.	Kerosene	45000																																				
6.	Diesel	45000																																				
7.	Methane	50000																																				
3.	CNG	50000																																				
9.	LPG	55000																																				
10.	Biogas	35000-40000																																				
11.	Hydrogen	150000																																				
20	The most common fire extinguisher is water. But water works only when things like wood and paper are on fire. If electrical equipment is on fire, water may conduct electricity and harm those trying to douse the fire. Water is also not suitable for fires involving oil and petrol. Do you recall that water is heavier than oil? So, it sinks below the oil, and oil keeps burning on the top. For fires involving electrical equipment and inflammable materials like petrol, carbon dioxide (CO ₂) is the best extinguisher. CO ₂ , being heavier than oxygen, covers the fire like a blanket. Since the contact between the fuel and oxygen is cut off, the fire is controlled. The added advantage of CO ₂ is that in most cases it does not harm the electrical equipment. How do we get the supply of carbon dioxide? It can be stored at high pressure as a liquid in cylinders. In what form is the LPG stored in cylinders? When released from the cylinder, CO ₂ expands enormously in volume and cools down. So, it not only forms a blanket around the fire, it also brings down the temperature of the fuel. That is why it is an excellent fire extinguisher. Another way to get CO ₂ is to release a lot of dry powder of chemicals like sodium bicarbonate (baking soda) or potassium bicarbonate. Near the fire, these chemicals give off CO ₂	4																																				

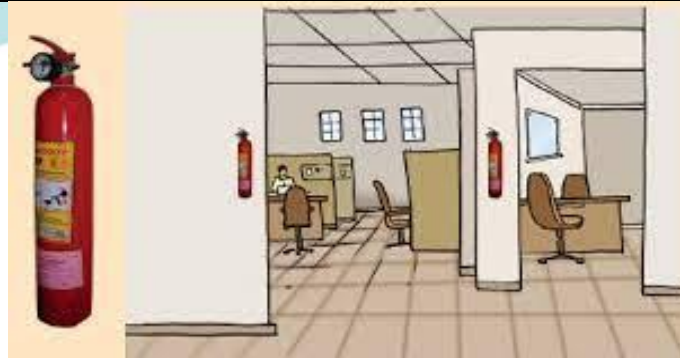

<https://images.app.goo.gl/TVoHPm3uhZCuCTQ56>

1. LPG stands for.
2. How do we extinguish fire when things like wood and paper are on fire?
3. Why do we not use water to control fire involving electrical equipment?
4. Why do we use CO₂ as fire extinguisher fire involving electrical equipment and inflammable materials?

ANSWER KEY (CHAPTER 4- Combustion and Flame)

Q No	SECTION A	MARKS																				
1	(c)	1																				
2	(d)	1																				
3	(d)	1																				
4	(b)	1																				
5	(b)	1																				
6	(c)	1																				
7	(a)	1																				
8	(d)	1																				
SECTION B																						
9	The substances which have very low ignition temperature and can easily catch fire with a flame are called inflammable substances. Any 2 example	2																				
10	Oxides of sulphur and nitrogen, SO ₂ and NO ₂	2																				
11	Substances which have very low ignition temperature catch fire easily and have high ignition temperature are difficult to burn.	2																				
12	A foam fire extinguisher puts out fires by covering the flames with a thick blanket of foam. CO ₂ fire extinguisher	2																				
13	<table border="1" style="width: 100%; border-collapse: collapse; margin-bottom: 5px;"> <thead> <tr> <th style="text-align: center;">S. No</th> <th style="text-align: center;">Material</th> <th style="text-align: center;">Combustible</th> <th style="text-align: center;">Non- combustible</th> </tr> </thead> <tbody> <tr> <td style="text-align: center;">1</td> <td>Wood</td> <td style="text-align: center;">Yes</td> <td style="text-align: center;">No</td> </tr> <tr> <td style="text-align: center;">2</td> <td>Stone</td> <td style="text-align: center;">No</td> <td style="text-align: center;">Yes</td> </tr> <tr> <td style="text-align: center;">3</td> <td>Paper</td> <td style="text-align: center;">Yes</td> <td style="text-align: center;">No</td> </tr> <tr> <td style="text-align: center;">4</td> <td>Glass</td> <td style="text-align: center;">No</td> <td style="text-align: center;">Yes</td> </tr> </tbody> </table>	S. No	Material	Combustible	Non- combustible	1	Wood	Yes	No	2	Stone	No	Yes	3	Paper	Yes	No	4	Glass	No	Yes	2
S. No	Material	Combustible	Non- combustible																			
1	Wood	Yes	No																			
2	Stone	No	Yes																			
3	Paper	Yes	No																			
4	Glass	No	Yes																			
SECTION C																						
14	A. Hottest Part/outer zone of complete combustion B. Moderately Hot/middle zone of partial combustion C. Least Hot/innermost zone of unburnt wax vapours	3																				
15	<table border="1" style="width: 100%; border-collapse: collapse; margin-bottom: 5px;"> <thead> <tr> <th style="text-align: center;">S. No</th> <th style="text-align: center;">Fuel</th> <th style="text-align: center;">Examples</th> </tr> </thead> <tbody> <tr> <td style="text-align: center;">1</td> <td>Solid fuel</td> <td>(a) Wood and (b) Coal</td> </tr> <tr> <td style="text-align: center;">2</td> <td>Liquid fuel</td> <td>(a) Petrol (b) Diesel</td> </tr> <tr> <td style="text-align: center;">3</td> <td>Gaseous fuel</td> <td>(a) LPG (b) CNG</td> </tr> </tbody> </table>	S. No	Fuel	Examples	1	Solid fuel	(a) Wood and (b) Coal	2	Liquid fuel	(a) Petrol (b) Diesel	3	Gaseous fuel	(a) LPG (b) CNG	3								
S. No	Fuel	Examples																				
1	Solid fuel	(a) Wood and (b) Coal																				
2	Liquid fuel	(a) Petrol (b) Diesel																				
3	Gaseous fuel	(a) LPG (b) CNG																				
16	Three Characteristics of ideal fuel 1. Easy to burn 2. High calorific value 3. Easy to store etc.	3																				
SECTION D																						
17	Burning of coal, diesel and petrol produces oxides of sulphur and nitrogen which dissolve in rain water and form acids. Such rain is called acid rain after burning of coal, diesel and petrol.	5																				

	Effects on plants and animals- adverse effect on plants in animals it leads to many skin diseases like allergy and skin cancer etc. Animals living in water may cause death. Old monuments and buildings also get affected by acid rain.	
18	<p>Precautions taking in using LPG at homes</p> <ol style="list-style-type: none"> 1. Cleaning the gas burner regularly and properly. 2. Changing the delivery pipe regularly. 3. Making use of strong delivery pipes. 4. Check-up of related appliances at regular intervals. 5. Keep safe storing places. 6. Always keep sufficient distance between gas stove and LPG cylinder etc 	5
SECTION E		
19	<ol style="list-style-type: none"> 1. Hydrogen has highest calorific value 2. Cow dung cake 3. Mass of fuel= Mass of heat released/calorific value $90000/45000= 2 \text{ kg}$ 	4
20	<ol style="list-style-type: none"> 1. Liquefied Petroleum Gas 2. Water we use when things like wood and paper are on fire. 3. Water may conduct electricity and harm those trying to douse the fire 4. Carbon dioxide (CO₂) is the best extinguisher. CO₂, being heavier than oxygen, covers the fire like a blanket. Since the contact between the fuel and oxygen is cut off, the fire is controlled. 	4

CHAPTER 5- Conservation of plants and animals

Q NO	SECTION A	MARKS
1	Fertile land convert into deserts is known as (a) deforestation (b) desertification (c) conservation (d) none of these.	1
2	The national park in Uttarakhand is (a) Bandipur national park (b) Kaziranga national park (c) Jim Corbett national park (d) Satpura national park	1
3	When no member of a species exists, it is known as (a) endemic species (b) endangered species (c) extinct (d) vulnerable species.	1
4	A species found only in one particular place is known as (a) endemic (b) vulnerable (c) endangered (d) extinct.	1
5	How many Biosphere Reserves in India has the Indian Government established? (a) 20 (b) 5 (c) 10 (d) 14	1
6	The variety of life on the earth is commonly referred to as (a) biodiversity (b) biosphere (c) afforestation (d) none of these.	1
7	Assertion – Protected areas for flora and fauna are called sanctuaries, national parks and biosphere reserves. Reason -These protected areas have similar nature and habitat for flora and fauna. a) Assertion and reason both are correct statement and reason is correct explanation for assertion. b) Assertion and reason both are correct statement and reason is not correct explanation for assertion. c) Assertion is correct statement but reason is wrong statement. d) Assertion is wrong statement but reason is correct statement.	1
8	Assertion: Red data book has a record of all endangered animals. Reason: Endangered species need to be identified for giving them proper protection	1

	<p>a) Assertion and reason both are correct statement and reason is correct explanation for assertion.</p> <p>b) Assertion and reason both are correct statement and reason is not correct explanation for assertion.</p> <p>c) Assertion is a correct statement but reason is wrong statement.</p> <p>d) Assertion is a wrong statement but reason is correct statement.</p>													
SECTION B														
9	Why should paper be recycled?	2												
10	Name two wildlife sanctuaries present in your state.	2												
11	Give a comparison between wildlife sanctuaries and national park.	2												
12	Describe causes of deforestation, drought and desertification.	2												
13	Explain how deforestation is associated with global warming.	2												
SECTION C														
14	Write at least two names of the following species in the table given below.	3												
	<table border="1"> <thead> <tr> <th>S.No</th> <th>Species</th> <th>Plants and animals</th> </tr> </thead> <tbody> <tr> <td>1</td> <td>Endangered species</td> <td>(a) (b)</td> </tr> <tr> <td>2</td> <td>Endemic species</td> <td>(a) (b)</td> </tr> <tr> <td>3</td> <td>Extinct species</td> <td>(a) (b)</td> </tr> </tbody> </table>	S.No	Species	Plants and animals	1	Endangered species	(a) (b)	2	Endemic species	(a) (b)	3	Extinct species	(a) (b)	
S.No	Species	Plants and animals												
1	Endangered species	(a) (b)												
2	Endemic species	(a) (b)												
3	Extinct species	(a) (b)												
15	Define the term . Red Data Book a. Migration b. Reforestation	3												
16	What is the ecosystem? Write the components of the ecosystem with examples.	3												
SECTION D														
17	Find out about any five national parks in different parts of your country and locate them in the outline map of your country India.	5												
														

CC BY-SA 3.0 DEED
Attribution-ShareAlike 3.0 Unported

18	Write the national parks, wild life sanctuaries and biosphere reserve in the states mentioned in the table below.	5																														
	<table border="1"> <thead> <tr> <th>S. No</th> <th>State</th> <th>National Park</th> <th>Wildlife sanctuary</th> <th>Biosphere reserve</th> </tr> </thead> <tbody> <tr> <td>1</td> <td>Karnataka</td> <td></td> <td></td> <td></td> </tr> <tr> <td>2</td> <td>Andhra Pradesh</td> <td></td> <td></td> <td></td> </tr> <tr> <td>3</td> <td>Madhya Pradesh</td> <td></td> <td></td> <td></td> </tr> <tr> <td>4</td> <td>Assam</td> <td></td> <td></td> <td></td> </tr> <tr> <td>5</td> <td>Uttarakhand</td> <td></td> <td></td> <td></td> </tr> </tbody> </table>	S. No	State	National Park	Wildlife sanctuary	Biosphere reserve	1	Karnataka				2	Andhra Pradesh				3	Madhya Pradesh				4	Assam				5	Uttarakhand				
S. No	State	National Park	Wildlife sanctuary	Biosphere reserve																												
1	Karnataka																															
2	Andhra Pradesh																															
3	Madhya Pradesh																															
4	Assam																															
5	Uttarakhand																															
SECTION E																																
19	<p>Read the passage and answer the question given below.</p> <p>A great variety of plants and animals exist on earth. They are essential for the well-being and survival of mankind. To preserve biodiversity, to prevent extinction of endangered species, and to maintain ecological balance in nature, wildlife and forests should be conserved. Habitat is a place in the environment where an organism lives. Today, a major threat to survival of these organisms is deforestation. We know that deforestation means clearing of forests and using that land for other purposes. Trees in the forest are cut for many purposes. Some natural causes of deforestation are forest fires and severe droughts. The answer to deforestation is reforestation. Reforestation is restocking of the destroyed forests by planting new trees. The planted trees should generally be of the same species which were found in that forest. We should plant at least as many trees as we cut. Reforestation can take place naturally also.</p> <p>i) Name the place in the environment where organisms live. ii) Why should Wildlife and forests be conserved:. iii) Any two causes of deforestation iv) Restocking of the destroyed forests known as</p>	4																														
20	<p>Read the passage and answer the question given below.</p> <p>Professor Ahmad explains about Red Data Book to the children. He tells them that the Red Data Book is the source book which keeps a record of all the endangered animals and plants. Red Data Book is maintained internationally by an organisation. India also maintains Red Data Book for plants and animals found in India. The excursion party then enters deeper into the forest under the guidance of Madhavji. They sit near the Tawa Reservoir to relax for some time. Paheli observes some of the birds near the river. Madhavji tells the children that these are migratory birds. These birds have flown here from other parts of the world. Migratory birds fly to far away areas every year during a particular time because of climatic changes. They fly for laying eggs as the weather in their natural habitat becomes very cold and inhospitable. Birds who cover long distances to reach another land are known as migratory birds. Professor Ahmad draws attention of the children to another cause of deforestation. He tells them that it takes 17 full grown trees to make one tonne of paper. Therefore, we should save paper. Professor Ahmad also says that paper can be recycled five to seven times for use. If each student saves at least one sheet of paper in a day, we can save many trees in a year. We should save, reuse used paper and recycle it. By this we not only save trees but also save energy and water needed for</p>	4																														

manufacturing paper. Moreover, the amount of harmful chemicals used in paper making will also be reduced. Professor Ahmad suggests that the answer to deforestation is reforestation. Reforestation is restocking of the destroyed forests by planting new trees. The planted trees should generally be of the same species which were found in that forest. We should plant at least as many trees as we cut. Reforestation can take place naturally also. If the deforested area is left undisturbed, it re-establishes itself.

1. Name the birds who cover long distances to reach another land.
2. By which act in India aimed at preservation and conservation of natural forests and meeting the basic needs of the people living in or near the forests.
3. We can save paper?
4. What is a "red data book"?



ANSWER KEY (CHAPTER 5- Conservation of plants and animals)

Q NO	SECTION A	MARKS
1	b	1
2	c	1
3	c	1
4	a	1
5	d	1
6	a	1
7	b	1
8	a	1
SECTION B		
9	It causes unchecked deforestation by reducing forest cover. It leads to the loss of natural flora and fauna. It eventually will lead to decreased oxygen in the environment which will affect all the organisms and the environment. Hence, we should save paper.	2
10	According to state two wildlife sanctuaries for example U.P a- Katarniaghat Sanctuary b- Hastinapur Sanctuary	2
11	Wildlife Sanctuary: Areas where animals are protected from any disturbance to them and their habitat. National Park: Areas reserved for wild life where they can freely use the habitats and natural resources.	2
12	Droughts can be triggered by natural causes such as weather patterns. But increasingly they are caused by human activity like deforestation. forests are cut for some of the purposes mentioned below: 1 Procuring land for	2

	cultivation. 1 Building houses and factories, 1 Making furniture or using wood as fuel. This leads to drought Removal of the top layer of the soil exposes the lower, hard and rocky layers. This soil has less humus and is less fertile. Gradually the fertile land gets converted into deserts. It is called desertification .																										
13	When forests are cut down, much of that stored carbon is released into the atmosphere again as carbon dioxide (CO ₂). This is how deforestation and forest degradation contribute to global warming.	2																									
SECTION C																											
14	<table border="1"> <thead> <tr> <th>S.No</th> <th>Species</th> <th>Plants and animals</th> </tr> </thead> <tbody> <tr> <td>1</td> <td>Endangered species</td> <td>(a)Wild buffalo (b)Barasingha</td> </tr> <tr> <td>2</td> <td>Endemic species</td> <td>(a)Sal Plant (b)Flying squirrel</td> </tr> <tr> <td>3</td> <td>Extinct species</td> <td>(a)Dinosaur (b)Mammoth</td> </tr> </tbody> </table>	S.No	Species	Plants and animals	1	Endangered species	(a)Wild buffalo (b)Barasingha	2	Endemic species	(a)Sal Plant (b)Flying squirrel	3	Extinct species	(a)Dinosaur (b)Mammoth	3													
S.No	Species	Plants and animals																									
1	Endangered species	(a)Wild buffalo (b)Barasingha																									
2	Endemic species	(a)Sal Plant (b)Flying squirrel																									
3	Extinct species	(a)Dinosaur (b)Mammoth																									
15	<ul style="list-style-type: none"> . Red Data Book- Is the source book which keeps a record of all the endangered animals and plants. a. Migration-Migratory birds fly to far away areas every year during a particular time because of climatic changes. b. Reforestation-Reforestation is the restocking of destroyed forests by planting new trees. 	3																									
16	Interaction between plants, animals and microorganisms (Biotic components) with water, soil, air and sunlight (abiotic components) in an area is called ecosystem. Ecosystem has two components Biotic components plants and animals Abiotic components Water and sunlight	3																									
SECTION D																											
17	ANY FIVE NATIONAL PARKS IN INDIA	5																									
18	Write the national parks, wild life sanctuaries and biosphere reserve in the states mentioned in the table below. <table border="1"> <thead> <tr> <th>S. No</th> <th>State</th> <th>National Park</th> <th>Wildlife sanctuary</th> <th>Biosphere reserve</th> </tr> </thead> <tbody> <tr> <td>1</td> <td>Karnataka</td> <td>Bandipur</td> <td>Kaveri wildlife sanctuaries</td> <td>Nilgiri biosphere reserve</td> </tr> <tr> <td>2</td> <td>Andhra Pradesh</td> <td>PapiKonda National Park</td> <td>Sri Venkateswara Wildlife Sanctuary</td> <td>Seshachalam</td> </tr> <tr> <td>3</td> <td>Madhya Pradesh</td> <td>Kanha National park</td> <td>Nauradehi Wildlife Sanctuary</td> <td>Satpura tiger reserve</td> </tr> <tr> <td>4</td> <td>Assam</td> <td>Kagiranga national park</td> <td>Assam Garampani Wildlife Sanctuary</td> <td>Manas</td> </tr> </tbody> </table>	S. No	State	National Park	Wildlife sanctuary	Biosphere reserve	1	Karnataka	Bandipur	Kaveri wildlife sanctuaries	Nilgiri biosphere reserve	2	Andhra Pradesh	PapiKonda National Park	Sri Venkateswara Wildlife Sanctuary	Seshachalam	3	Madhya Pradesh	Kanha National park	Nauradehi Wildlife Sanctuary	Satpura tiger reserve	4	Assam	Kagiranga national park	Assam Garampani Wildlife Sanctuary	Manas	5
S. No	State	National Park	Wildlife sanctuary	Biosphere reserve																							
1	Karnataka	Bandipur	Kaveri wildlife sanctuaries	Nilgiri biosphere reserve																							
2	Andhra Pradesh	PapiKonda National Park	Sri Venkateswara Wildlife Sanctuary	Seshachalam																							
3	Madhya Pradesh	Kanha National park	Nauradehi Wildlife Sanctuary	Satpura tiger reserve																							
4	Assam	Kagiranga national park	Assam Garampani Wildlife Sanctuary	Manas																							

5	Uttarakhand	Corbett national park	Kedarnath wildlife sanctuary	Sonanadi Biosphere reserve	
SECTION E					
19	A. Habitat B. To preserve biodiversity. To prevent extinction of endangered species. Maintain ecological balance in nature. c. Cutting trees use forest land for many purposes (agriculture, construction) . Reforestation				4
20	A. Migratory bird B. forest conservation act C. recycling D. Keeping the records of all endangered plants and animals				4

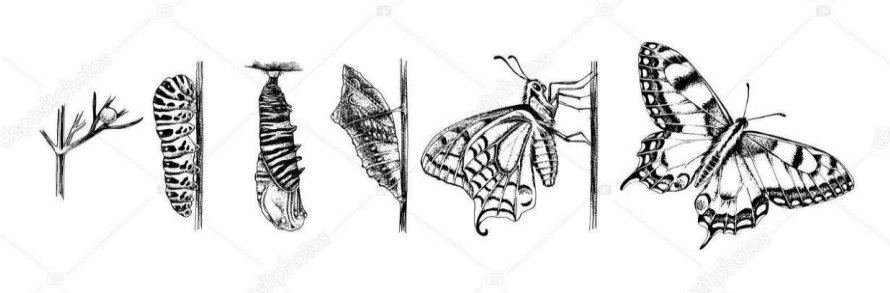
CHAPTER- 6 : REPRODUCTION IN ANIMALS

Q N O	SECTION A	MARK S
1	<p>Which part of the female reproductive system involves in the development of embryo?</p> <ol style="list-style-type: none"> Oviduct Uterus Ovary Ovum 	1
2	<p>Which of the following statements is correct about Viviparous organisms?</p> <ol style="list-style-type: none"> Such organisms lay eggs in water. Such organisms lay eggs and has internal fertilization. Such organisms give birth to young ones. Such organisms lay eggs and has external fertilization. 	1
3	<p>From the following organisms which one does not involve in the metamorphosis process?</p> <ol style="list-style-type: none"> Frog Mouse Mosquito Silkworm 	1
4	<p>Which of the following statements is incorrect about asexual reproduction?</p> <ol style="list-style-type: none"> A single parent is involved. This process of reproduction occurs in a short time. Fertilisation or gamete formation takes place. The offspring is genetically similar. 	1
5	<p>The hen is odd in the list of animals given below. (human beings, cows, dogs, hens). The reason for it is</p> <ol style="list-style-type: none"> it undergoes internal fertilisation. It is oviparous. It is viviparous. It undergoes external fertilisation. 	1
6	<div style="text-align: center;">  </div> <p style="text-align: center;">  Image ID: 285047578 www.depositphotos.com </p> <p>What will you call this process?</p> <ol style="list-style-type: none"> Development of embryo Fertilization Formation of foetus Metamorphosis 	1

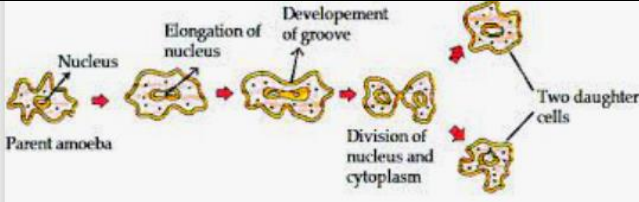
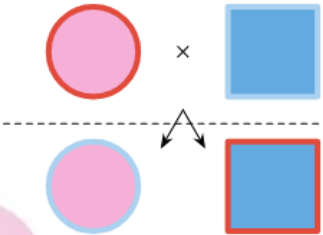
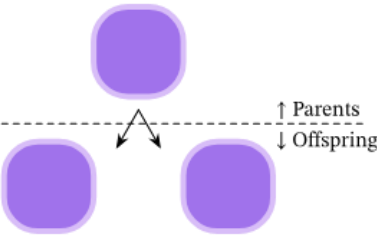
7	<p>Assertion- Number of male gametes produced by terrestrial animals are larger than female gametes.</p> <p>Reason- External fertilization takes place in some of the terrestrial animals.</p> <p>a. Assertion and Reason are true and the Reason is the correct explanation of the Assertion.</p> <p>b) Assertion and Reason are true but the Reason is NOT the correct explanation of the Assertion.</p> <p>c) Assertion is true, but the Reason is false.</p> <p>d) Assertion is false, but the Reason is true.</p>	1
8	<p>Assertion- Testis in males always present outside the body.</p> <p>Reason- Formation of sperm requires lower temperature than the body.</p> <p>a. Assertion and Reason are true and the Reason is the correct explanation of the Assertion.</p> <p>b) Assertion and Reason are true but the Reason is NOT the correct explanation of the Assertion.</p> <p>c) Assertion is true, but the Reason is false.</p> <p>d) Assertion is false, but the Reason is true.</p>	1
SECTION B		
9	Why amoeba cannot have asexual reproduction?	2
10	 <p>Identify the process shown in the figure and justify why is it named so?</p>	2
11	What could be the possibilities if a frog lays eggs on land?	2
12	An organ named A , is a part of the female reproductive system involved in very important functions such as fertilization and transportation of ovum to the B . Identify the A and B .	2
13	What differences do you find in organisms performing internal fertilization and external fertilization?	2
SECTION C		
14	<div style="display: flex; justify-content: space-around;"> <div style="text-align: center;"> <p>Sexual reproduction</p>  </div> <div style="text-align: center;"> <p>Asexual reproduction</p>  <p>↑ Parents ↓ Offspring</p> </div> </div>	3

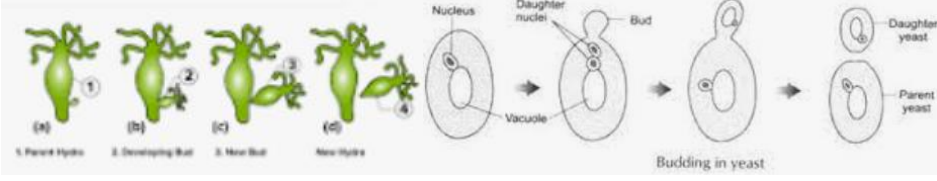
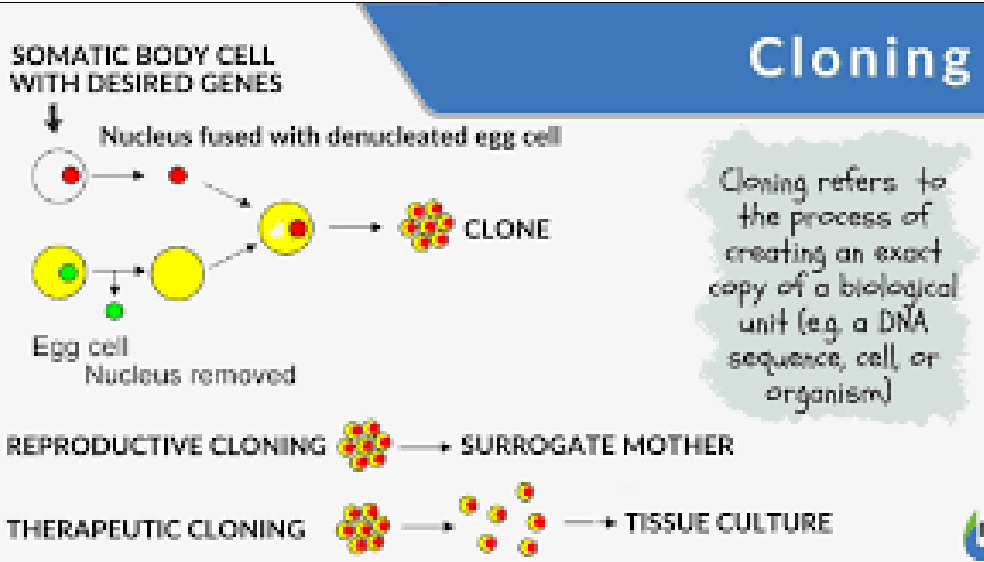
	Understand the concept given in the figure and answer why daughter cell of amoeba remain similar to the parent but offspring of human beings results different from the parent.	
15	Write any 3 differences between oviparous and viviparous.	3
16	 <p>Observe both the figures and answer what difference you find in budding in hydra and budding in yeast.</p>	3
SECTION D		
17	<p>Ram with his family went to a picnic spot near a pond. He saw some jelly-like mass floating on the sides of the pond. He asked about this to his father. His father explained to him that these are frog's eggs and are millions in number. Ram wondered if all of them get hatched, what will happen to other aquatic animals?</p> <ul style="list-style-type: none"> . What type of fertilisation is shown by frogs? a. Why do frogs lay eggs in large amounts? b. Is Ram's concern about hatching of too many eggs at a time will affect the aquatic animals correct? Why? c. What Value of Ram is shown here? 	5
18	<p>Draw a flow chart to summarize the Human reproductive stages.</p> <p>Note: Take the following terms as key points to draw.</p> <ul style="list-style-type: none"> . Pre-fertilization (formation of gamete) a. Fertilization, (if fertilized or not) b. Post-fertilization. 	5
SECTION E		
19	 <p>Cloning</p> <p>Cloning refers to the process of creating an exact copy of a biological unit (e.g. a DNA sequence, cell, or organism)</p> <p>REPRODUCTIVE CLONING → SURROGATE MOTHER</p> <p>THERAPEUTIC CLONING → TISSUE CULTURE</p> <p>https://images.app.goo.gl/EerXZNczAaw6uBgX9</p>	4

Cloning is a technique scientist use to make exact genetic copies of living things. Genes, cells, tissues, and even whole animals can all be cloned. Some clones already exist in nature. Single-celled organisms like bacteria make exact copies of themselves each time they reproduce. In humans, identical twins are similar to clones. They share almost the exact same genes. Identical twins are created when a fertilized egg split in two.

- . Do you think kittens are clones of their parents (cats)? Justify your answer?
- i. Write any two examples in which organisms reproduce their clones.
- ii. What differences do you find in inheritance of characteristics from parents of an asexual reproduction and sexual reproduction?

20

Development of Embryo

4

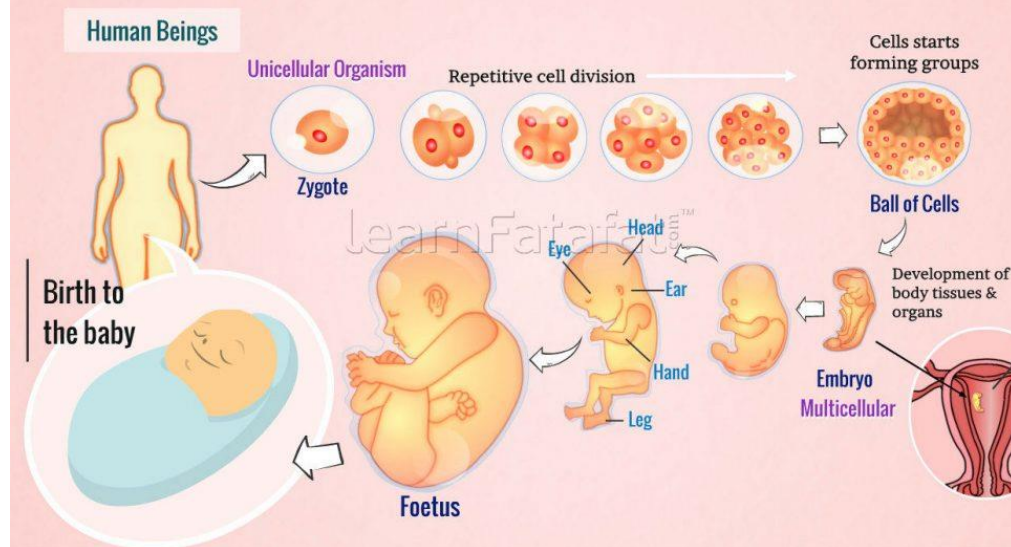

<https://images.app.goo.gl/He8Yn7TSKYWwG3TV7>

Foetal development is an orderly and intricate process. It begins before you even know you're pregnant and ends with the birth of your baby. Between conception and delivery, there are many detailed steps that have to occur. There are three stages of foetal development: germinal, embryonic and foetal.

Germinal stage

The germinal stage is the shortest stage of foetal development. It begins at conception when a sperm and egg join in your fallopian tube. The sperm fertilizes the egg and creates a zygote.

Embryonic stage

The embryonic stage lasts from about the third week of pregnancy until the eighth week of pregnancy. The blastocyst begins to take on distinct human characteristics. It's now called an embryo. Structures and organs like the neural tube (which later becomes the brain and spinal cord), head, eyes, mouth and limbs form. The embryo's heart begins to develop and pulse around the sixth week. Buds that will become arms and legs also form around the sixth week.

Foetal stage

The foetal stage of development begins around the ninth week and lasts until birth. This is when the embryo officially turns into a foetus. The foetus gets

its assigned sex around nine weeks of pregnancy, although your healthcare provider can't detect it on ultrasound yet.

- . Where does the fertilization of male and female gametes take place in the human reproductive system?
- i. Which method is used to check the developmental stage of an embryo?
- ii. What is the difference between germinal stage and foetal stage?
- iii. Why a male cannot give birth to a child?

ANSWER KEY CHAPTER- 6: Reproduction in animals

Q NO	SECTION A	MARKS
1	b)	1
2	c)	1
3	b)	1
4	c)	1
5	b)	1
6	d)	1
7	b)	1
8	a)	1
	SECTION B	
9	Amoeba is unicellular organism and does not have organs to produce gametes for fertilization	2

10	Given diagram shows Binary fission in amoeba. It is named as binary fission because the amoeba is divided into two daughter cells. (Binary – Two, Fission - division)		2											
11	Eggs of frogs are delicate in nature because they do not have a protective layer. If frogs lay their eggs on the land it may be damaged by high temperature and air. Male gametes of frogs swim to the eggs with the help of water if it will be laid on land fertilization will not take place.		1 + 1											
12	A – Oviduct, B - Uterus		1 + 1											
13	<table border="1"> <thead> <tr> <th>EXTERNAL FERTILIZATION</th> <th>INTERNAL FERTILIZATION</th> </tr> </thead> <tbody> <tr> <td>Takes place outside the female's body.</td> <td>Takes place inside the female's body.</td> </tr> <tr> <td>Usually, a large number of gametes are released in the surrounding medium (for example water).</td> <td>Male gametes are released inside the body of the female by a copulatory organ.</td> </tr> <tr> <td>Organisms that use external fertilization to reproduce must either live in the water or return to the water for reproduction.</td> <td>Animals that have internal fertilization have completely transitioned to life on land.</td> </tr> <tr> <td>As the chance of fertilization in water is generally less, hence, a large number of gametes are released.</td> <td>The number of gametes produced in this mode is relatively less.</td> </tr> </tbody> </table>	EXTERNAL FERTILIZATION	INTERNAL FERTILIZATION	Takes place outside the female's body.	Takes place inside the female's body.	Usually, a large number of gametes are released in the surrounding medium (for example water).	Male gametes are released inside the body of the female by a copulatory organ.	Organisms that use external fertilization to reproduce must either live in the water or return to the water for reproduction.	Animals that have internal fertilization have completely transitioned to life on land.	As the chance of fertilization in water is generally less, hence, a large number of gametes are released.	The number of gametes produced in this mode is relatively less.	1 m for each point (any)		
EXTERNAL FERTILIZATION	INTERNAL FERTILIZATION													
Takes place outside the female's body.	Takes place inside the female's body.													
Usually, a large number of gametes are released in the surrounding medium (for example water).	Male gametes are released inside the body of the female by a copulatory organ.													
Organisms that use external fertilization to reproduce must either live in the water or return to the water for reproduction.	Animals that have internal fertilization have completely transitioned to life on land.													
As the chance of fertilization in water is generally less, hence, a large number of gametes are released.	The number of gametes produced in this mode is relatively less.													
SECTION C														
14	In sexual reproduction a child is getting genes from two different parents but in asexual reproduction a single parent is transferring characters.		3											
15	<table border="1"> <thead> <tr> <th></th> <th>Oviparous</th> <th>Viviparous</th> </tr> </thead> <tbody> <tr> <td>1</td> <td>Females lay eggs outside the body.</td> <td>Females give birth to young ones.</td> </tr> <tr> <td>2</td> <td>Fertilization can be external or internal.</td> <td>Fertilization always internal</td> </tr> <tr> <td>3</td> <td>Egg contains yolk, albumin and essential supplements for the proper development of the young one.</td> <td>The foetus obtains nourishment inside the female body through the food reserves of the female.</td> </tr> </tbody> </table>		Oviparous	Viviparous	1	Females lay eggs outside the body.	Females give birth to young ones.	2	Fertilization can be external or internal.	Fertilization always internal	3	Egg contains yolk, albumin and essential supplements for the proper development of the young one.	The foetus obtains nourishment inside the female body through the food reserves of the female.	1+1+1
	Oviparous	Viviparous												
1	Females lay eggs outside the body.	Females give birth to young ones.												
2	Fertilization can be external or internal.	Fertilization always internal												
3	Egg contains yolk, albumin and essential supplements for the proper development of the young one.	The foetus obtains nourishment inside the female body through the food reserves of the female.												
16	<table border="1"> <thead> <tr> <th>S. No.</th> <th>Budding in yeast</th> <th>budding in Hydra</th> </tr> </thead> <tbody> <tr> <td>1</td> <td>Bud in Yeast is unicellular</td> <td>Bud in Hydra is a multicellular</td> </tr> <tr> <td>2</td> <td>Bud originates from a small protuberance on the parent body</td> <td>Bud arises due to the repeated mitotic division</td> </tr> <tr> <td>3</td> <td>Yeast gets its daughter nuclei and it may or may not separate from the parent body</td> <td>In Hydra the daughter buds are multicellular and there is no development of daughter buds</td> </tr> </tbody> </table>	S. No.	Budding in yeast	budding in Hydra	1	Bud in Yeast is unicellular	Bud in Hydra is a multicellular	2	Bud originates from a small protuberance on the parent body	Bud arises due to the repeated mitotic division	3	Yeast gets its daughter nuclei and it may or may not separate from the parent body	In Hydra the daughter buds are multicellular and there is no development of daughter buds	1+1+1
S. No.	Budding in yeast	budding in Hydra												
1	Bud in Yeast is unicellular	Bud in Hydra is a multicellular												
2	Bud originates from a small protuberance on the parent body	Bud arises due to the repeated mitotic division												
3	Yeast gets its daughter nuclei and it may or may not separate from the parent body	In Hydra the daughter buds are multicellular and there is no development of daughter buds												

SECTION D		
17	<p>Frog shows external fertilization.</p> <p>a. Mortality rate is very high for tadpoles as their predators are more. Many of the eggs do not develop due to not being fertilized. So for the continuation of their species, they lay eggs in large numbers.</p> <p>b. No, his concern is not correct because most of the eggs either never develop or are preyed by other animals. So the survival chance of a frog from its egg to an adult frog is very low.</p> <p>c. Ram is inquisitive, future thinker and eco-concerned.</p>	1+2+1+1
18		5
SECTION E		
19	<p>NO, because kitten is produced by sexual reproduction.</p> <p>i. Binary fission in amoeba, Budding in hydra</p> <p>ii. Children produced through asexual reproduction are identical to their parents as they inherit all characters from them but children produced through sexual reproduction are different from parents as they are inheriting from both the parents.</p>	1+1+2
20	<p>Oviduct</p> <p>i. Ultrasound</p> <p>ii. Germinal stage has cellular level of organization and foetus has organ level of organization.</p> <p>iii. Male does not have a uterus to develop an embryo.</p>	1+1+1+1

CHAPTER 7- Reaching the age of adolescence

Q NO	SECTION A	MARKS
1	Period of adolescence in girls lies on which age difference? a. 14 years to 20 years b. 11 years to 19 years c. 19 years to 25 years d. 11 years till death	1
2	Why does a boy of age 15 years' experience more sweating than the boy with age 5 during playing? a. Due to increased physical activity b. Due to increased activity of sweat gland c. Due to increased height d. Due to increased age	1
3	Which of the following is male gonads? (a) Moustache (b) Chest (c) Testes (d) Hair	1
4	The unfertilised egg always has _____ chromosome. a. Y b. X c. XY d. XX	1
5	Pimples appeared during adolescence as an indication for which of the following activities? a. Due to increased physical activity b. Due to increased activity of oil gland c. Due to increased height d. Due to increased age	1
6	Mark the incorrect statement about onset of puberty in males. a. sudden increase in height. b. growth of hair at different parts of the body like face, armpit and pubic region, development of moustache and beard. c. development of Adam's apple in throat, voice becomes hoarse shoulders become broader and chest wider. d. ovaries get enlarged and begin producing eggs	1
7	If a sperm carrying X chromosomes fertilizes with the ovum, what will be the sex of the child? a. Girl b. Boy c. Transgender d. Bisexual	1

8	Which of the following determines the sex of the baby? (a) Chromosomes (b) Chloroplast (c) Hormones (d) Pituitary gland	1
---	---	---

SECTION B

9	Calculate approximal height of a boy whose height is 162 cm at the age of 14 years. (Note: % of full height for 14 year of boys – 92%)	2
---	---	---

10	A person is suffering from dysfunctional pancreas. What medical ailments is the person likely to suffer?	2
----	--	---

11	 <p>Which hormone will be released in such a situation? What will happen if an organ fails in releasing that hormone?</p>	2
----	--	---

12	A person observed a number of tadpoles in a small water body. After 4 months he observed that it still remains in the same stage (tadpoles). What could be the reason for the lack of growth in tadpoles?	2
----	---	---

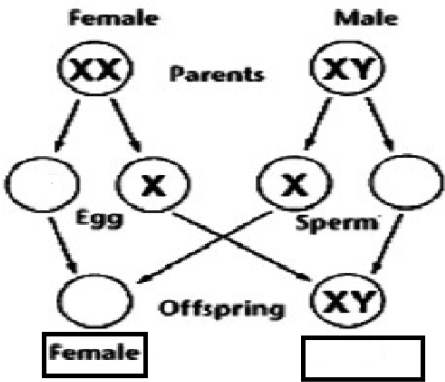
13	<p>Complete the flowchart of sex determination-</p> 	2
----	---	---

SECTION C

14	What is the age group for menstruation cycle in females? Is it possible for a lady to be naturally pregnant after 65 years? Justify your answer.	3
----	--	---

15	Complete the table-	3								
	<table border="1" style="width: 100%;"> <thead> <tr> <th>s. no.</th> <th>Name of gland</th> <th>Hormone released</th> <th>Function</th> </tr> </thead> <tbody> <tr> <td>1</td> <td>Pancreas</td> <td></td> <td></td> </tr> </tbody> </table>	s. no.	Name of gland	Hormone released	Function	1	Pancreas			
s. no.	Name of gland	Hormone released	Function							
1	Pancreas									

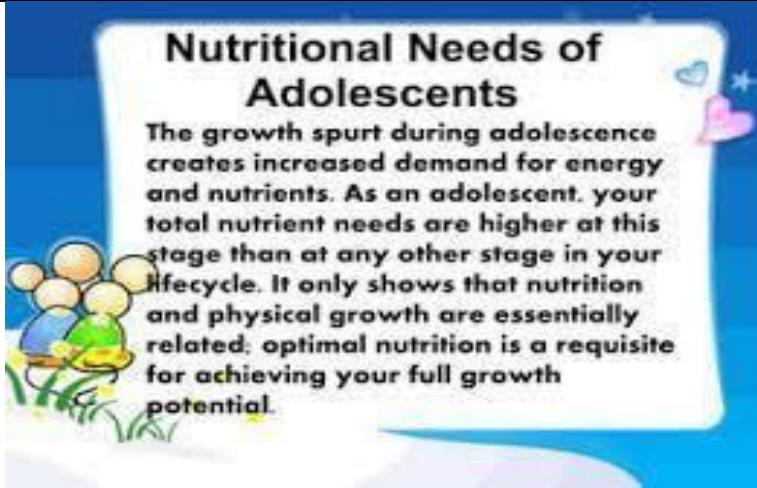
	2		Adrenaline		
	3			Breast development	
16	If a person calls you from outside your home, how will you be able to tell that person is male or female without watching? Mention any 2 other criteria by which we can differentiate between male and female?				3
SECTION D					
17	Draft a notice by using sub points given below to display in your classroom to create awareness regarding personal hygiene. [Personal hygiene- * importance of personal hygiene, * steps to clean yourself, * routine to be followed, etc.]				5
18	A doctor faced a patient who was complaining about sperm formation. When the doctor checked he found that everything was properly functioning. Help them to find out the problem by answering some questions. I. Which organ doctor would have examined for sperm formation? II. What could be the problem if organ releasing sperm is alright? III. How will this problem affect a person's life in future?				5
SECTION E					
19	 <p>Nutritional Needs of Adolescents</p> <p>The growth spurt during adolescence creates increased demand for energy and nutrients. As an adolescent, your total nutrient needs are higher at this stage than at any other stage in your lifecycle. It only shows that nutrition and physical growth are essentially related; optimal nutrition is a requisite for achieving your full growth potential.</p> <p>https://images.app.goo.gl/ZtRCo77D7a4tcnyYA</p> <p>Read the paragraph given in the picture and answer the following question with your understanding-</p> <p>I. Why are nutritional needs higher at adolescence? II. Which type of food should we take during adolescence? III. Does nutrition have any effect on our growth? Explain. IV. How will you make friends aware about good food and good health?</p>				4
20					4

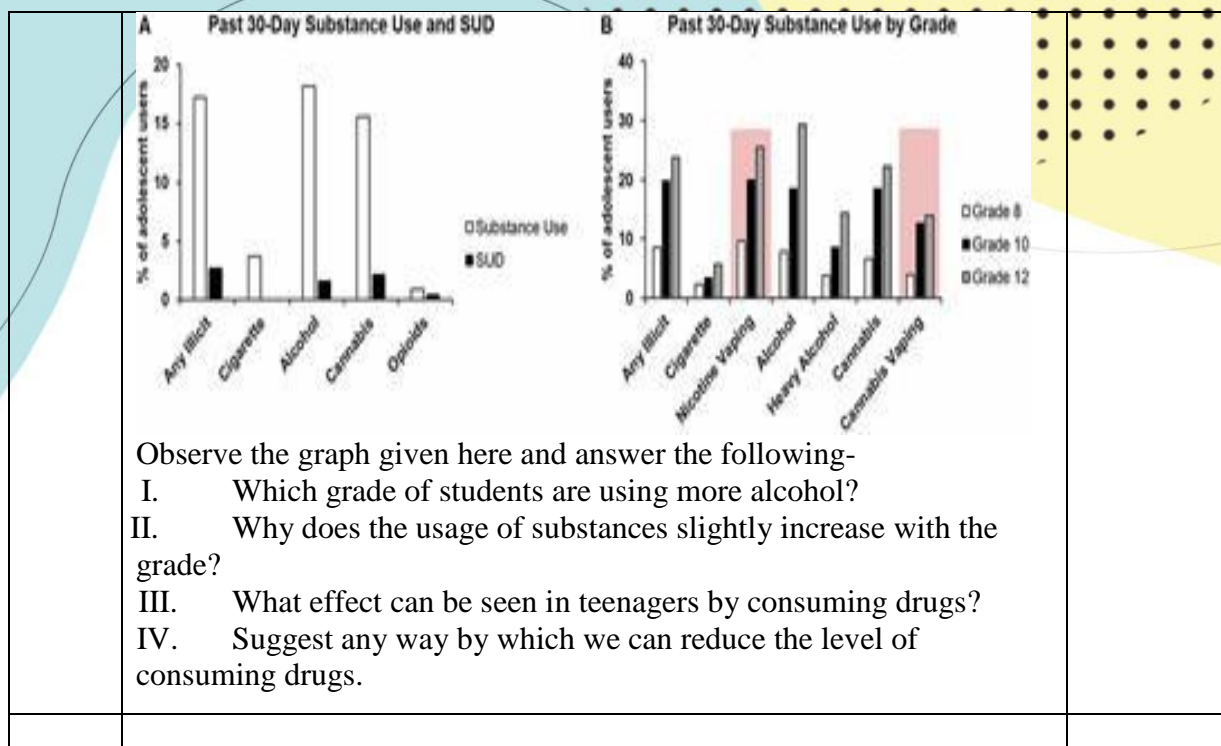

ANSWER KEY (CHAPTER 7- Reaching the age of adolescence)

Q NO	SECTION A	MARKS
1	b)	1
2	b)	1
3	c)	1
4	b)	1
5	b)	1
6	d)	1
7	a)	1
8	a)	1
SECTION B		
9	Calculation for full height = Present height / % of full height at this age x 100 = 162 cm / 92 x 100 176 cm	2
10	His body will not be able to secrete insulin and will have diabetes. (or any other correct answer)	2
11	Adrenaline will be secreted from adrenal. If this hormone will not be secreted then this will limit the ability to respond to stressful situations.	1+1

12	Water could have a lack of iodine which indirectly affects the process of metamorphosis.	2
----	--	---

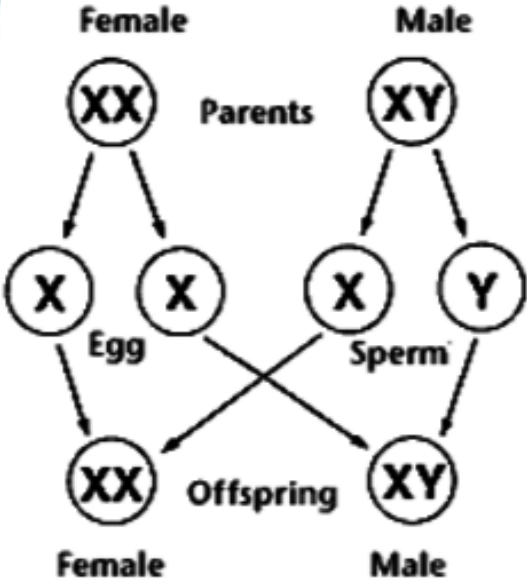
13	<p>Complete the flowchart of sex determination-</p>  <pre> graph TD P1((XX)) --- P2((XY)) P1 --> G1((X)) P1 --> G2((X)) P2 --> G3((X)) P2 --> G4((Y)) G1 --> O1((XX)) G2 --> O1 G3 --> O2((XY)) G4 --> O2 O1 --- OF1(Female) O2 --- OF2(Male) </pre>	2
----	---	---

SECTION C

14	A female may have menstruation from 11 years to 50 years of age. A lady with age can not be pregnant after age of 65 because body is not producing ovum.	3
----	--	---

15	Complete the table-	$\frac{1}{2} + \frac{1}{2} + \frac{1}{2} + \frac{1}{2} + \frac{1}{2} + \frac{1}{2}$																
	<table border="1" style="width: 100%; border-collapse: collapse;"> <thead> <tr> <th style="width: 10%;">s. no.</th> <th style="width: 20%;">Name of gland</th> <th style="width: 20%;">Hormone released</th> <th style="width: 50%;">Function</th> </tr> </thead> <tbody> <tr> <td>1</td> <td>Pancreas</td> <td>Insulin</td> <td>Decrease blood sugar level</td> </tr> <tr> <td>2</td> <td>Adrenal gland</td> <td>Adrenaline</td> <td>To adjust stress</td> </tr> <tr> <td>3</td> <td>Ovary</td> <td>Estrogen</td> <td>Breast development</td> </tr> </tbody> </table>		s. no.	Name of gland	Hormone released	Function	1	Pancreas	Insulin	Decrease blood sugar level	2	Adrenal gland	Adrenaline	To adjust stress	3	Ovary	Estrogen	Breast development
s. no.	Name of gland		Hormone released	Function														
1	Pancreas		Insulin	Decrease blood sugar level														
2	Adrenal gland	Adrenaline	To adjust stress															
3	Ovary	Estrogen	Breast development															

16	I will recognize her/ him because male and females differ in pitch and loudness.	1+2
----	--	-----

SECTION D

17		5
----	--	---









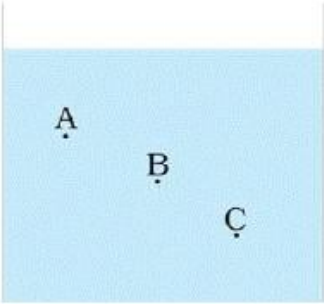
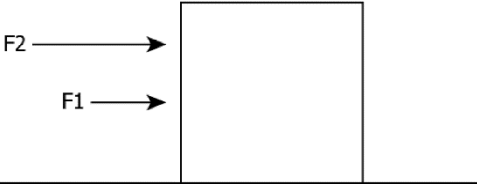

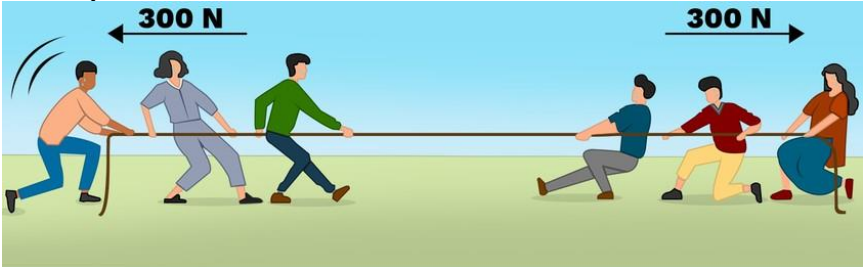
Any relevant notice

18	<ul style="list-style-type: none"> I. Testes II. pituitary gland not releasing stimulating hormone III. He will become impotent 	5
SECTION E		
19	<ul style="list-style-type: none"> I. For growth and development II. Healthy and Protein rich (fruits and green vegetable) III. Yes, nutrition will help our cells to divide for growth and development IV. By sharing experiences (any suggestion) 	1+1+1+1
20	<ul style="list-style-type: none"> I. Grade 12 II. Addiction increases during adolescence III. They can be suffered with diseases IV. By awareness 	1+1+1+1

CHAPTER 8- FORCE AND PRESSURE

Q. No.	Question(s)	Marks
SECTION A		
1.	What does the bursting of an air-filled balloon depict? (a) Gas exerts pressure on the walls of its container. (b) Liquid exerts pressure on the walls of its container. (c) Solids exert pressure. (d) All of the above.	1m
2.	Two objects repel each other. This repulsion could be due to (a) frictional force only (b) electrostatic force only (c) magnetic force only (d) either a magnetic or an electrostatic force	1m
3.	Figure below shows a container filled with water. Which of the following statements is correct about pressure of water? 	1m
	(a) Pressure at A > Pressure at B > Pressure at C (b) Pressure at A = Pressure at B = Pressure at C (c) Pressure at A < Pressure at B > Pressure at C (d) Pressure at A < Pressure at B < Pressure at C	
4.	A person X pushes a cart with a force. Another person Y starts pushing the cart in the opposite direction with the same force. How does it affect the cart? (a) it brings the cart to rest (b) it changes the direction of cart (c) it increases the speed of the cart (d) it will change the shape of the cart	1m
5.	The image shows a block in which force F1 and F2 are acting. 	1m
	What would be the net force on the block? (a) F1 (b) F2 (c) F2 – F1 (d) F1 + F2	
6.	The area of a small plate is 15cm x 15cm and air in column exerts a force of 2250 N on it. How much atmospheric pressure is exerted by air? (a) N/cm ² (b) 10 N/cm ² (c) 15 N/cm ² (d) 150 N/cm ²	1m
Q.No. 7 & 8 are Assertion and Reason Type Questions. In those questions, a statement of Assertion (A) is followed by a statement of Reason (R). Mark the correct choice as:		

	<p>(a) If both Assertion (A) and Reason (R) are true and Reason (R) is correct explanation of Assertion (A).</p> <p>(b) If both Assertion (A) & Reason (R) are true and Reason (R) is not correct explanation of Assertion(A)</p> <p>(c) If Assertion (A) is true but Reason (R) is false.</p> <p>(d) If Assertion (A) is false but Reason (R) is true.</p>	
7.	<p>Assertion: As we move to higher altitudes, breathing can become difficult.</p> <p>Reason: At higher altitude there is decrease in the atmospheric pressure.</p>	1m
8.	<p>Assertion: Sharp knives are used to cut the vegetables.</p> <p>Reason: Sharp edges exert more pressure.</p>	1m
9.	<p>What happens in a tug-of-war when both the opponent teams pull the rope with equal force?</p> 	1m
10.	<p>Why would a porter keep a round piece of cloth over his head before carrying heavy luggage on his head?</p> 	1m
11.	<p>Name the forces acting on a plastic bucket containing water held above ground level in your hand.</p>  <p>Discuss why the forces acting on the bucket do not bring a change in its state of motion.</p>	1m
SECTION B		
12.	<p>A boy having area of 70 cm sq. exerts a pressure of 7N/cm sq. on the ground. What will be the force acting on the ground ?</p>	2m



13.	When a person stands on a cushion, the depression is much more than when he lies down on it. Explain with a reason.	2m
SECTION C		
15.	Why do deep sea divers wear special suits while diving? 	3m
16.	Why is a heavy truck fitted with six to eight wheels? 	3m
SECTION D		
17.	(a) How does a rubber sucker work? (2m)  (b) Why do some people suffer from nose bleeding at high altitudes? (3m)	5m
18.	(a) Reason out why skis are used to glide over snow? (2m)  (b) Why is the wall of a dam made stronger and thicker at the bottom than at the top? (3m) 	5m
SECTION E		
Case-Based Questions: Q.No. 19 to 20 are case-based questions. A passage is followed by four questions.		
19.	The weight of the atmosphere presses down on the earth's surface and creates pressure on it. The atmospheric pressure at a place decrease with an increase in altitude. As we go up the length of the air column above us decreases. This means that its weight and the atmospheric pressure are	4m

ANSWER KEY (CHAPTER 8- Force and Pressure)

1.	(a) Gas exerts pressure on the walls of its container.	1m
2.	Two objects repel each other. This repulsion could be due to (d) either a magnetic or an electrostatic force	1m
3.	d) Pressure at A < Pressure at B < Pressure at C	1m
4.	(a) it brings the cart to rest	1m
5.	(d) $F_1 + F_2$	1m
6.	(b) 10 N/cm^2	1m
	Q.No. 7 & 8 are Assertion and Reason Type Questions. In those questions, a statement of Assertion (A) is followed by a statement of Reason (R). Mark the correct choice as: (a) If both Assertion (A) and Reason (R) are true and Reason (R) is correct explanation of Assertion (A). (b) If both Assertion (A) & Reason (R) are true and Reason (R) is not correct explanation of Assertion(A) (c) If Assertion (A) is true but Reason (R) is false. (d) If Assertion (A) is false but Reason (R) is true.	
7.	(a) both Assertion (A) and Reason (R) are true and Reason (R) is correct explanation of Assertion (A).	1m
8.	(a) both Assertion (A) and Reason (R) are true and Reason (R) is correct explanation of Assertion (A).	
9.	The rope doesn't move in any direction.	1m
10.	Pressure is inversely proportional to area. Larger the area, the lesser the pressure exerted. The porter is arranging a larger surface area by keeping a round piece of cloth over his head, so that the luggage exerts less pressure on his head.	1m
11.	(i) Muscular force of arms acting upward. (ii) Force of gravity acting downward. Both the forces are acting in equal and opposite directions with equal magnitude. Thus, they cancel each other's effect.	1m
12.	490 N	2m
13.	While standing on a cushion, only the feet are in contact with the cushion. The whole weight of the body rests on two feet which has a lesser area of contact. While lying on cushion, the entire body surface is in contact with the cushion and the entire body provides a larger surface area. So, the depression is more while standing than while resting on cushion.	2m
14.	Two forces acting on the rocket: i. Upward force applied by the rocket engine. ii. Downward gravitational force applied by the earth.	2m

15.	Liquid pressure increases with depth: Pressure is high at the bottom therefore deep sea divers have to wear special suits to protect themselves from high pressure otherwise it may crush their bodies.	3m
16.	A heavy truck is fitted with six to eight wheels because increased area reduces the pressure on wheels so they do not burst or damage on the road. That is why a truck has broad tyres so that there is less pressure on the ground and the tyres do not sink in the soil.	3m
17.	(a) When we press the sucker, the air between its cup and the surface escapes out. The sucker sticks to the surface because the pressure of the atmosphere works on it. To pull the sucker out, the applied force should be large enough so as to overcome the atmospheric pressure. (2m) (b) The atmospheric pressure is at a maximum on the surface of the earth. When we go to a higher altitude (say a high mountain), then the atmospheric pressure decreases. So, at high altitudes, the atmospheric pressure becomes much less than our blood pressure. Since our blood is at a higher pressure than the outside pressure, therefore, some of the blood vessels in our body burst and nose bleeding can occur at high altitudes. (3m)	5m
18.	(a) Skis are constructed in such a way that they have a large surface area which helps to reduce the pressure on snow. This makes sure that the skis do not sink too far in the snow. (2m) (b) The wall of a dam is made stronger and thicker at the bottom than at the top so as to withstand high sideways pressure exerted by deep water stored in the reservoir of the dam. Pressure is inversely proportional to area, therefore, more the area the lesser the pressure exerted. So, high pressure exerted by dams can be borne on ground and that avoids breakage of the dam. That is the reason why dams are always constructed with a wide base. (3m)	5m
Case-Based Questions: Q.No. 19 to 20 are case-based questions. A passage is followed by four questions.		
19.	(i) The pressure exerted by the air around us is known as atmospheric pressure. (1m) (ii) The pressure of the air inside our body is the same as that of the pressure outside. This balances the difference in pressure inside and outside the body. So, our bodies do not get crushed due to intense atmospheric pressure. (1m) (iii) Some people feel their ear-popping at the top of the mountain due to the decrease in the air pressure. The ears pop to balance the difference in pressures inside and outside of the body. (1m) (iv) Barometer measures the atmospheric pressure. (1m)	4m
20.	(i) (c) lightning (1m) (ii) (b) magnetic force (1m) (iii) Grains of sugar get attracted to the inside surface of a container due to electrostatic force of attraction. The container and the small grains have opposite charges. (1m) (iv) Two objects can be made to attract or repel each other by rubbing against each other. (1m)	4m

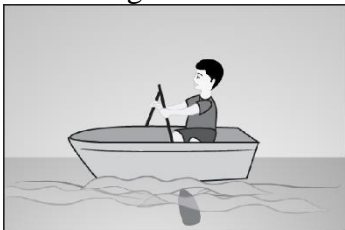
CHAPTER 9- FRICTION

Question Number	Question(s)	Marks
1.	Once a body starts moving on table, the friction that comes into play is: (a) static friction (b) sliding friction (c) limiting friction (d) none of these	1m
2.	Which of the following statements is incorrect? (a) Friction acts on a ball rolling along the ground (b) Friction acts on a boat moving on water (c) Friction acts on a bicycle moving on a smooth road (d) Friction does not act on a ball moving through air	1m
3.	The image shows a person rowing a boat over a river. <div style="text-align: center;">  </div> <p>Identify the number of bodies experiencing friction. (a) 1, boat because of the river (b) 1, boat because of the person (c) 2, boat because of the river and the person because of air (d) 2, boat because of air and river and the person because of air</p>	1m
4.	In a large commercial complex, there are four ways to reach the main road. One of the paths has loose soil, the second is laid with polished marble, the third is laid with bricks and the fourth has gravel surface. It is raining heavily and Priya wishes to reach the main road. The path on which she is least likely to slip is (a) loose soil. (b) polished marble. (c) bricks (d) gravel.	1m
5.	In Figure below, a boy is shown pushing the box from right to left. <div style="text-align: center;">  </div> <p>The force of friction will act on the box (a) from right to left (\leftarrow) (b) from left to right (\rightarrow) (c) vertically downwards (\downarrow) (d) vertically upwards (\uparrow)</p>	1m
6.	In a cycling race, it is observed that a racer bends his body forward.	1m



Why does he bend his body forward while cycling in a race?

- (a) to feel comfortable
- (b) to reduce his body weight while cycling
- (c) to reduce the air drag
- (d) to increase his energy consumption

Q.No.7 & 8 are Assertion-Reason type questions. In those questions, a statement of Assertion (A) is followed by a statement of Reason (R).

Mark the correct choice as:

- (a) If both Assertion (A) and Reason (R) are true and Reason (R) is correct explanation of Assertion (A).
- (b) If both Assertion (A) & Reason (R) are true and Reason (R) is not correct explanation of Assertion(A)
- (c) If Assertion (A) is true but Reason (R) is false.
- (d) If Assertion (A) is false but Reason (R) is true.

7.	Assertion: It is harder to start to slide a heavy box across the floor than to keep it sliding. Reason: Sliding friction is less than rolling friction.	1m
8.	Assertion: Rocket has a special streamlined body. Reason: It decreases the friction.	1m
9.	How does the friction depend on the nature of the surface?	2m
10.	Why is the surface of the sides of a matchbox made rough?	2m
11.	Why is sliding friction slightly smaller than static friction?	2m
12.	A pencil eraser loses tiny pieces of rubber each time you use it. Why does this happen?	2m
13.	Cartilage is present in the joints of our body, which helps in their smooth movement. With advancing age, this cartilage wears off. How would this affect the movement of joints? 	2m

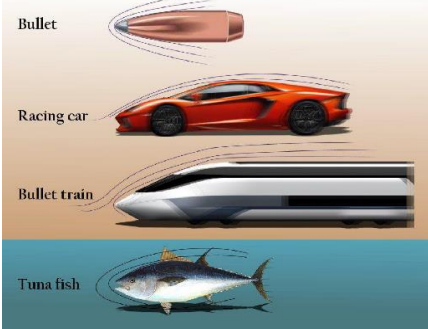
14.	Why do car wheels often spin on icy roads?	3m
15.	Why will a pencil write on a paper, but not on a glass?	3m
16.	Why is it easy to drag a mat when nobody is sitting on it but difficult when somebody is sitting on it?	3m
17.	Write five consequences if friction never existed on this earth or in air.	5m
18.	<p>(a) What's the advantage for sportsmen in using shoes with spikes? (2m)</p>  <p>(b) Why should objects moving in fluids have special shapes? (3m)</p> 	5m

Case-based Questions Q. No 19 & 20 are case-based questions. A passage is followed by four questions. Answer the questions.

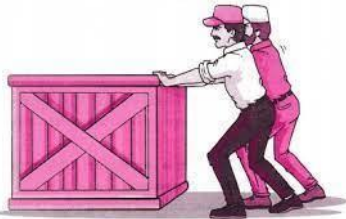
19.	<p>Static friction is a force that keeps an object at rest. Static friction definition can be written as: The friction experienced when individuals try to move a stationary object on a surface, without actually triggering any relative motion between the body and the surface on which it is on.</p> <p>(a) Two friends are trying to push a heavy load as shown in figure below.</p>  <p>Suggest a way which will make this task easier for them. (1m)</p> <p>(b) What enables a ladder to lean against the wall? (1m)</p> <p>(c) Why are treaded tyres used in cars, trucks and bulldozers? (2m)</p>	4m
20.	<p>Friction always works in the direction opposite to the direction in which the object is moving, or trying to move. Friction also produces heat. If you rub your hands together quickly, you will feel them get warmer. Friction can be a useful force because it prevents our shoes slipping on the pavement when we walk and stops car tyres skidding on the road. When you walk, friction is caused between the tread on shoes and the ground. This friction acts to grip the ground and prevent sliding. Sometimes we want to reduce friction. For example, we use oil to reduce the friction between the moving parts inside a car engine. In many</p>	4m

machines, friction is reduced by using ball bearings. The reduced friction means there is less wear on the moving parts and less heat produced.

- i) When does friction arise? (1m)
- ii) Why should we apply oil on the hinges of the door? (1m)
- iii) Gymnasts apply some coarse substance on their hands. Why? (1m)
- iv) Why can friction never be eliminated? (1m)

ANSWER KEY (CHAPTER-9 FRICTION)

Question Number & Type	Question(s)	Marks
1.	(b) sliding friction	1m
2.	(d) Friction does not act on a ball moving through air	1m
3.	(d) 2, boat because of air and river and the person because of air	1m
4.	(d) gravel.	1m
5.	(b) from left to right (→)	1m
6.	(c) to reduce the air drag	1m
7.	(c)	1m
8.	(a)	1m
9.	Rough surfaces offer more resistance and provide more friction, smooth surfaces offer less resistance and provide less friction.	2m
10.	Rough surface on the sides of a matchbox provides more resistance. On rubbing the matchstick against this rough surface, heat is generated.	2m
11.	Sliding friction is smaller than static friction because two sliding objects find less time to get interlocked against each other's irregularities of surfaces; as a result, they experience less friction.	2m



12.	When we use a pencil eraser, friction between the eraser and the paper rubs off some rubber particles from the eraser. Thus, the eraser loses tiny pieces of rubber due to friction.	2m
13.	The wearing off of cartilage will increase the friction. As a result the movement of joints will become difficult which may lead to joint pains. In medical language, such a condition is called arthritis.	2m
14.	A car wheels spins on icy roads because the treads of the car can no longer maintain the proper friction to keep it moving. Due to the smooth surface of ice, the friction reduces and the car wheels spins.	3m
15.	We are able to write on paper because there is friction between the tip of the pencil and paper. We are not able to write on a glass because the glass surface is very smooth due to which friction between the tip of the pencil and glass surface is less.	3m
16.	Friction is caused by the interlocking of the irregularities in the two surfaces. It is obvious that the force of friction will increase if the two surfaces are pressed harder. So, it is easy to drag a mat when nobody is sitting on it but difficult when someone is sitting on it.	3m
17.	If there is no Friction then: Friction prevents objects from sliding apart. Everything would slide to the lowest point if there was no friction. It would be impossible to scale anything. We will be unable to write without friction. We will not be able to fly a kite. No riding a bike, cycle, or even a car or bus without friction. There are no machines in businesses, so there are no mechanics without friction. We would not have been able to sit, walk, run, or dance without friction	5m
18.	(a) Spikes under the shoes give a good grip by increasing friction on the running track for the athletes. The athletes need a good grip on the track to run at the fastest speed. (b) The fluids, like various liquids or air, i.e. gaseous medium, also exert frictional force known as drag. To minimise the effect of this drag, streamlining the movement of the object in the fluid is necessary, which can be achieved by changing the shape of the body. Objects moving in fluids must have a specific shape called streamlined shapes or aerodynamic shapes. A streamlined Shape or Aerodynamic Shape is a shape that overcomes fluid friction.	5m
19.	(a) Keeping rollers (like pieces of cylindrical logs) under the heavy box will make their task of pushing the box easier. (b) Friction of the ladder against the floor enables it to lean against the wall. (c) Treads in tyres of trucks, buses and bulldozers are deep cuts, ridges and grooves that provide better grip with the ground thereby increasing friction for better handling.	4m
20.	Friction always works in the direction opposite to the direction in which the object is moving, or trying to move. Friction also produces heat. If you rub your hands together quickly, you will feel them get warmer. Friction can be a useful force because it prevents our shoes slipping on the pavement when we walk and stops car tyres skidding on the road.	4m

When you walk, friction is caused between the tread on shoes and the ground. This friction acts to grip the ground and prevent sliding. Sometimes we want to reduce friction. For example, we use oil to reduce the friction between the moving parts inside a car engine. In many machines, friction is reduced by using ball bearings. The reduced friction means there is less wear on the moving parts and less heat produced.

- i) Friction arises when the irregularities between the surfaces of two objects in contact interlock against each other.
- ii) We apply oil on the hinges of the door that gets jammed because oil acts as a lubricant to reduce friction at hinges.
- iii) Gymnasts apply some coarse substance on their palms to get a good grip and increase the friction while lifting weights.
- iv) Friction can never be eliminated because no surface is perfectly smooth. There are always some irregularities.

CHAPTER 10- SOUND

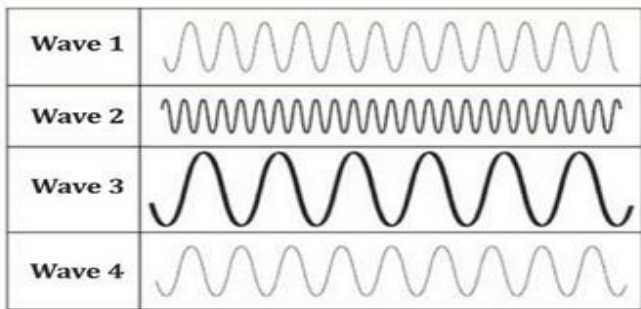
Question	Question(s)	Marks
1.	The voice box is also called as - a) stomach b) heart c) larynx d) mouth	1m
2.	In dholak, sound is produced due to a) stretched membrane b) stretched strings c) air column d) none of these	1m
3.	If we tighten the strings of an instrument, pitch will be a) higher b) lower c) constant d) no pitch	1m
4.	A vibrating body should oscillate minimum how many times per second to make a sound audible for humans? a) 10 times b) 20 times c) 30 times d) 40 times	1m
5.	Flash and thunder are produced simultaneously. But thunder is heard a few seconds after the flash is seen. Why? a) The speed of sound is greater than the speed of light. b) The speed of sound is equal to the speed of light. c) The speed of light is greater than the speed of sound. d) All of the above	1m
6.	A student does an activity where he puts a ringing phone in the glass tumbler. The student covers the glass tumbler with his hand. The student removes air from the glass tumbler by using a vacuum and observes the sound of the phone fainting gradually. What can be concluded from the observation? a) sound eventually fades away b) sound gets absorbed by the surrounding c) sound requires a medium to travel d) sound get reflected in all directions	1m
	S.No. 7 & 8 are Assertion and Reason Type Questions – In the following questions, a statement of Assertion (A) is followed by a statement of Reason (R). Mark the correct choice as: a) If both Assertion (A) and Reason (R) are true and Reason (R) is the correct explanation of Assertion (A). b) If both Assertion (A) & Reason (R) are true and Reason (R) is not correct explanation of Assertion(A) c) If Assertion (A) is true but Reason (R) is false. d) If Assertion (A) is false but Reason (R) is true	

7.	<p>Assertion: Two persons on the surface of the moon cannot talk to each other.</p> <p>Reason: There is no atmosphere on the moon.</p>	1m
8.	<p>Assertion: The sound of the human voice is produced due to vibrations in the vocal cords.</p> <p>Reason: Vibration means a kind of rapid to and fro motion of an object.</p>	
9.	Why are some sounds louder than others? Which factor decides the shrillness in a sound?	2m
10.	It is known that vibration is necessary for producing sound. But why is the sound produced by every vibrating body not heard by us? (Such as tremors during an earthquake) What is the name of those sounds which have a frequency more than 20000 Hz?	2m
11.	<p>What does the working of a toy telephone tell us about sound?</p> <p>The picture shows four sound waves.</p>  <p>Which sound wave appears to have the highest frequency? Give a reason.</p>	2m
12.	 <p>It is a common sight to see working people at airports and factories wearing ear-protectors. Give reason for wearing such devices. To what extent can a human ear bear the noise?</p>	2m
13.	Suresh was enjoying the rainy season. Suddenly he is scared by a thunderbolt 4 seconds after he saw lightning in the east direction. Which formula we can use to find out the distance of lightning from Suresh? (Speed of light = 3×10^8 m/s) Find the distance of lightning from Suresh.	2m
14.	<p>On a hot summer day, a pesky little mosquito produced its warning sound near your ear. The sound is produced by the beating of its wings at a rate of about 600 wing beats per second.</p> <p>(i) What is the frequency in Hertz of the sound wave? (ii) What would be the time period of the sound wave?</p>	3m
15.	(i) How does a bow produce sound on violin strings?	3m

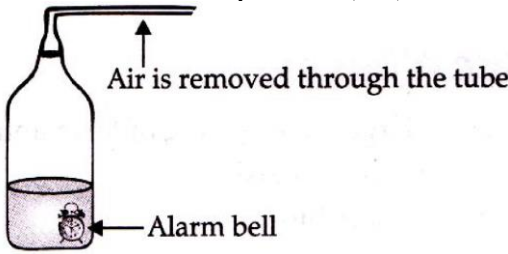

	(ii) How does a Jal tarang produce sound?	
16.	(i) What do we mean when we say metals are sonorous? (1m) (ii) What determines the shrillness of the sound produced by the voice of a baby? (1m) (iii) What are the three main causes of oceanic sound pollution? (3m)	3m
17.	(i) In the olden days, when people used to communicate using drums (talking drums), they used to beat the drums near a flowing water body. Analyze the reason why they chose to beat the drums near a flowing water body. (3m) (ii) Why don't we hear the sound of an explosion on the surface of the moon? (2m)	5m
18.	(i) An alarm bell is kept inside a vessel as shown in Figure below. A person standing close to it can distinctly hear the sound of alarm. Now if the air inside the vessel is removed completely how will the loudness of the alarm get affected for the same person? (3m)  (ii) Draw a diagram showing a soft sound and a louder sound. (2m)	5m
Case-based Questions Q. No 19 & 20 are case-based questions. A passage is followed by four questions. Answer the questions.		
19.	<p>Sound plays an important role in our life. It is a form of energy which makes us hear. Vibrating objects produce sound. Vibration is the to and fro or back and forth movement of an object. Sound needs a medium to travel. Hence, it cannot travel in a vacuum.</p> <p>Human beings have a voice box or larynx which is present in their throat on the upper side of the windpipe. The larynx has two vocal cords which have a narrow slit between them so that air can pass through it. As the lungs throw the air out of the windpipe, it passes through the slit and hence allows the production of sound as the vocal cords start vibrating. Since sound travels in the form of waves, it is important to study the characteristics of waves. The three main properties of waves are amplitude, frequency, and time period.</p> <p>The magnitude of disturbance in the medium on either side of the mean value is called amplitude. Larger the amplitude, louder the sound. The number of oscillations/vibrations per second is called frequency. which is expressed in Hertz (Hz). Time taken for one complete oscillation/vibration is the time period.</p> <p>i) Which part of the human throat is responsible for the voice produced by a human?</p>	4m

- ii) Why do astronauts need special talking devices on the moon?
- iii) We can hear heartbeats by using a stethoscope. What does it prove about sound?
- iv) What do you call the maximum displacement of a vibrating object from its mean position?

Sound is a form of energy that is produced when air molecules vibrate in a particular pattern called waves. Hence, sound is a wave. Sound is produced by vibrating objects. Vibration can be described as to and fro motion of objects. Sound always requires a medium to travel from the source of its production to the receiver end. Speed of sound is maximum in solids and minimum in gases.

Raghav kept a mini sound player in each of two similar containers. He then tightly covered both the containers with stretched plastic sheets. He placed some tiny rubber beads on the surface of the sheets. The picture shows what Raghav noticed when he turned on the sound player. Sound is a wave and waves have amplitude. Amplitude that decides loudness of sound is measured in decibels (dB).

Decibels and intensity, however, do not depend on the ear. They can be measured with instruments. A whisper is about 10 decibels while thunder is 100 decibels. Listening to loud sounds, sounds with intensities above 85 decibels, may damage your ears. If a noise is loud enough, over 120 decibels, it can be painful to listen to. One hundred and twenty decibels is the threshold of pain.

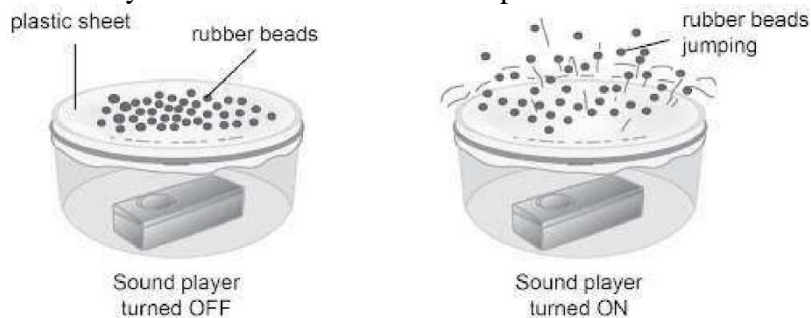

20.

4m

- (i) Why do the rubber beads jump on plastic sheet when sound player is turned on?
- (ii) Would the result of Raghav's activity change if fewer beads had been used? Explain your answer.
- (iii) Ria used a device to measure the loudness of a machine. She recorded her observations. Which of the following represents the correct measurement of loudness?
 - (a) 80 Hz (b) 80 seconds (c) 80 dB (d) 80 K
- (iv) Arrange the speed of sound in solids, liquids and gases in ascending order:
 - (a) Gas < Liquid < Solid
 - (b) Liquid < Gas < Solid
 - (c) Liquid < Solid < Gas
 - (d) Solid < Liquid < Gas

ANSWER KEY (CHAPTER 10- SOUND)

Question	Question(s)	Marks
1.	c) larynx	1m
2.	a) stretched membrane	1m
3.	a) higher	1m
4.	b) 20 times	1m
5.	c) The speed of light is greater than the speed of sound.	1m
6.	c) sound requires a medium to travel	1m
7.	(a)	1m
8.	(b)	
9.	Some sounds are louder than others due to their high amplitude. Shrillness in a sound is decided by its frequency.	2m
10.	Sound of every vibrating object may not be audible to us. This is because either that sound is below the audible range or above the audible range. Sounds which have a frequency more than 20000 Hz are called ultrasound.	2m
11.	When we hear sound through a toy telephone, we come to know that sound can travel through solids. Wave 2 appears to have the highest frequency because it shows a large number of oscillations in one second.	2m
12.	People working at airports and factories are often prone to very loud noises which may be harmful to their ears. So, to protect their eardrums, they wear special ear-protectors. A human ear can bear noise only upto 80 decibels.	2m
13.	We use the formula $\text{DISTANCE} = \text{SPEED} \times \text{TIME}$ to find the distance of lightning from Suresh. $\text{Distance} = (3 \times 10^8) \times 4 = 12 \times 10^8 \text{ m}$	2m
14.	(i) The frequency of the sound wave of wings of mosquito is 600 Hertz (ii) Time period is the inverse (reciprocal) of frequency. Hence time period of sound of wings of mosquito = $1 / 600$ i.e. 0.0016 seconds	3m
15.	(i) A violinist rubs his bow to create friction between the bow and the violin strings, thereby producing sound. (ii) A Jal tarang involves the vibrations of the air column right above the level of water in cups. As the vibrations of the air column vary, it produces music accordingly.	3m
16.	(i) Metals vibrate when they are struck. So, they produce sound and are called sonorous. (ii) Very small sized vocal cords (small length) are responsible for producing shrillness in the sound produced by the voice of the baby. (iii) Oceanic sound pollution is caused by – (i) Underwater blasting (ii) Dredging (iii) Underwater earthquakes	3m

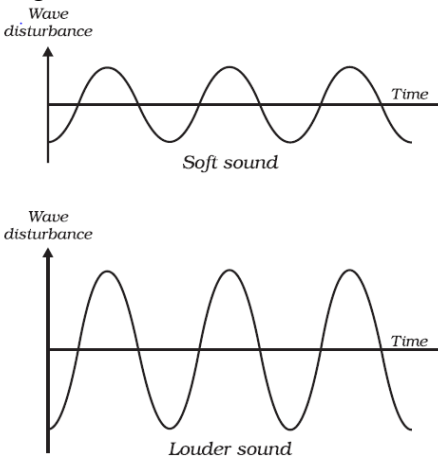
17.	<p>(i) Water is a denser medium, and hence, sound travels faster in it. Hence, beating drums near the flowing water body ensured that the sound travelled faster and farther to be heard at far off places.</p> <p>(ii) No matter how loud a sound may occur on earth, we will not be able to hear that sound on the surface of the moon because there is no atmosphere on the moon's surface. There is only vacuum and sound does not travel in vacuum.</p>	5m
18.	<p>(i) Initially, the person is able to hear the sound coming from air and water distinctly. But after some time, when the air is completely removed from the bottle, the sound will pass through the water and then the glass and finally reach the man. So, the man will not hear the sound which was coming through the air initially.</p> <p>(ii) Diagram showing a soft sound and a louder sound</p> 	5m
19.	<p>i) Larynx/vocal chord in the human throat is responsible for the voice produced by a human.</p> <p>ii) Astronauts need special talking devices on the moon because there is no atmosphere on the moon. There is a vacuum on the moon.</p> <p>iii) We can hear heartbeats by using a stethoscope. It proves that sound can travel through solids.</p> <p>iv) The maximum displacement of a vibrating object from its mean position is called amplitude.</p>	4m
20.	<p>(i) When a sound player is turned on, it creates sound waves due to its vibrations. This makes the rubber beads jump on the plastic sheet.</p> <p>(ii) Even if fewer beads had been used the result of Raghav's activity would not change. This is because the intensity of sound vibrations is not dependent upon the number of beads on the rubber sheet.</p> <p>(iii) The correct measurement of loudness is represented by - (c) 80 dB</p> <p>(iv) speed of sound in solids, liquids and gases in ascending order:</p> <p>(a) Gas < Liquid < Solid</p>	4m

CHAPTER 11 -CHEMICAL EFFECTS OF ELECTRIC CURRENT

Q NO	SECTION A	MARKS
1	<p>While performing an experiment a student observed that when electrodes are immersed in water and electricity passed, the bubbles are formed on the negative terminal. He was bit confused; can you help in identifying the gas:</p> <p>(a) Hydrogen (b) Carbon dioxide (c) Oxygen (d) Nitrogen</p>	1
2	<p>Tin cans, used for storing food, are made by electroplating tin onto iron. Why?</p> <p>(a) Tin gives a shiny appearance (b) To make the vessel cheap (c) Tin is less reactive than iron (d) To make the vessel lighter</p>	1
3	<p>When electric current is passed through the copper sulphate solution, copper sulphate dissociates into:</p> <p>(a) copper and sulphur (b) copper and oxygen (c) copper and sulphate (d) none of these</p>	1
4	<p>Shyam decided to test whether some fruits and vegetables conduct electricity or not. A magnetic compass was connected in a circuit is used to check:</p> <p>(a) Fast current (b) slow current (c) small current (d) none of these</p>	1
5	<p>When Ram purchased new articles like car parts, bath taps, kitchen gas burners, bicycle handlebars were shining for few months later they lost the shine as they were electroplated with:</p> <p>(a) chromium (b) zinc (c) tin (d) none of these</p>	1
6	<p>Ramprasad has an electroplating factory in Kanpur. Disposal of used conducting solutions is a major concern. Suggest him the best possible option in disposing waste</p> <p>(a) in the nearby river (b) in the nearby pond (c) in the nearby cornfield (d) according to the disposal guidelines of waste management bodies</p>	1
7	<p>Q. no 7-8 are Assertion - Reasoning based questions. These consist of two statements – Assertion (A) and Reason (R). Answer these questions selecting the appropriate option given below:</p> <p>(a) Both A and R are true and R is the correct explanation of A (b) Both A and R are true and R is not the correct explanation of A</p>	1

	<p>(c) A is true but R is false (d) A is False but R is true Assertion: Electroplating is a method of coating a metal on another metal using electric current Reason: Cobalt is used to give a shiny appearance in the electroplating process.</p>	
8	<p>Assertion: Distilled water is good conductor of electricity Reason: Small amounts of mineral salts present in water makes it a good conductor of water.</p>	1
SECTION B		
9	<p>Suhaas out of curiosity added a small amount of sugar in distilled water. Can you predict whether the resulting solution will be a good or bad conductor of electricity? On what basis you have come to conclusion.</p>	2
10	<p>Show with the help of a diagram that lemon juice and vinegar are good conductors of electricity.</p>	2
11	<p>Ram in one of the demonstrations has seen electric fires being extinguished with either using CO₂ extinguisher or mud but not water? Can you formulate a reason for it.</p>	2
12	<p>Current does not flow in a circuit if there is a gap between the two wires. Does it indicate that air is a poor conductor of electricity? Does air never conduct electricity? Assess your answer.</p>	2
13	<p>Give an example of the chemical effect of the electric current.</p>	2
SECTION C		
14	<p>(a)What is an LED? Justify its preferred use to other types of bulbs? (b) It is preferred to classify materials as good conductors and poor conductors instead of classifying them as conductors and insulators. (1.5m+1.5m)</p>	3
15	<p>Akshara is a very keen observer and seen her mother using some special jewellery during family functions that are very shiny but not precious. Analyse the reason as to why electroplated jewelleryes are in demand?</p>	3
16	<p>Suhaas is an ‘entrepreneur’ and has been provided a loan by a bank to set up a small electroplating unit. What object would you like to electroplate and for what purpose?</p>	3
SECTION D		
17	<p>(a). In a circuit, Ram observed that copper is deposited on the electrode connected to the battery’s negative terminal. Seema also repeats the same experiment. But she finds only one copper plate. Therefore, she takes a carbon rod as the negative electrode. Will copper still be deposited on the carbon rod? Explain your answer. (3m) (b).Ram who was living in the coastal region of Kerala tests the drinking water and seawater with his tester. He finds that the compass needle deflects more in the case of seawater. Can you analyse the reason behind it?. (2m)</p>	5
18	<p>(a). During the peak of monsoon my office needed to carry electrical repairs outdoors, so I called an electrician.? Is my action justifiable? Please justify your answer. (2m) (b). An electric current is passed into a conducting solution. What can be the three possible observations? (3m)</p> <p style="text-align: center;">OR</p> <p>Compare the advantages and disadvantages of electroplating?</p>	5

SECTION E

- 19 Gayathri made a circuit as shown in the figure. She observed that the bulb did not glow but on bringing a compass needle near it shows deflection. She was quite confused that if current is flowing through the circuit then why the bulb is not glowing. Meanwhile her friend Ram arrived and suggested her to add one more cell in the circuit. The bulb then started glowing. (courtesy NCERT Figure)

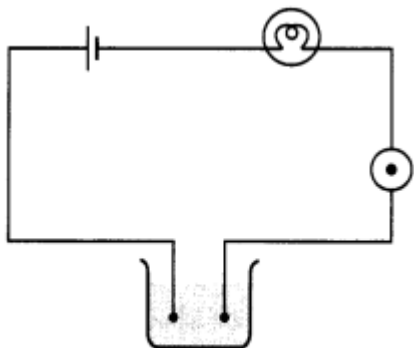

► Fig. 14.10

- (a) Define a circuit.
 (b) What does the deflection of a compass needle show?
 (c) Why did the bulb not glow in the first case but glow in the second case?
 (d) What value of Ram is shown here?
- 20 Madhu and her mother reached a jewellery shop to purchase some ornaments. She liked the necklace very much but her mother told her not to purchase it because it is not real gold. When she checked the information tag, it said 1gm gold. The necklace was quite big and heavy. She was surprised to see it and asked about it. The salesman explained that it is a gold-plated necklace. Then Sita checked that the process of depositing a layer of any desired metal on another material by means of electricity is called electroplating. It is one of the most common applications of the chemical effects of electric current. Nowadays, people prefer to buy gold-plated jewellery, similarly, iron articles are often coated with zinc or chromium to protect them from rusting and corrosion. In electroplating factories, the disposal of the used conducting solution is a major concern. It is a polluting waste and specific disposal guidelines should be followed to protect the environment.
- (a) What is electroplating (2m)
 (b) Write two applications of electroplating with possible reason (2m)



ANSWER KEY (CHAPTER 11- CHEMICAL EFFECTS OF ELECTRIC CURRENT)

Q NO	SECTION A	MARKS
1	a	1
2	c	1
3	c	1
4	c	1
5	a	1
6	d	1
7	c	1
8	d	1
	SECTION B	
9	When we add a small amount of sugar to distilled water, the resulting solution will be a poor conductor of electricity. Sugar will not produce ions when it is dissolved in water as it is a non- electrolyte substance. As for the conduction of electricity, free ions are required	2
10	Relevant diagram should be given marks FIG 14.2 NCERT TEXT BOOK	2
11	As water is a good conductor of electricity it can cause electrocution. Hence, water is avoided in extinguishing electric fires.	2
12	Air is a poor conductor of electricity if it is dry but in certain cases like during lightning and when air is moist, air may conduct electricity.	2
13	When an electric current is passed through water, then water dissociates into hydrogen and oxygen. This is an example of the chemical effect of electric current. (Any other correct example)	2
	SECTION C	
14	(a). The electric device which is used in the tester instead of the bulb is an LED. Its full form is Light Emitting Diode. It is preferred to other bulbs as it can glow even when weak or less current flows through it. (b) any relevant point can be given marks	3
15	Electroplated jewellerys are in demand because firstly, they are as shiny and attractive as real jewellerys. They are light-weighted and cost effective. Secondly, one feels free to wear it because of the growing problem of snatching and theft.	3
16	He can select the objects of his own choice and interest like electroplating jewellery items with gold and silver, wheel rims of vehicles with nickel, etc. It will make the objects shiny, attractive and durable. Any other relevant answer.	3
	SECTION D	
17	(a) Copper from the copper sulphate (CuSO_4) solution will be deposited on the carbon rod. Copper sulphate splits into copper and sulphate when an electric current is passed through the copper sulphate solution. The free copper gets drawn to the electrode connected to the battery's negative terminal, i.e. carbon rod, and gets deposited on it. Thus, Seema will obtain a layer of copper on a carbon rod. (b) The amount of salts dissolved in the seawater is more than that of the drinking water. So, seawater will be a better conductor than drinking	5

	water. This is the reason behind the increased deflection of the needle in the seawater compared to the drinking water.	
18	<p>(a). No, It is not safe for one to repair electrical appliances outdoors during heavy downpours. Rainwater is composed of some amount of dissolved salts that make it conductive. This can cause electric shocks and harm the electrician while working outdoors during heavy downpours. (3m)</p> <p>(b). Few possible observations when electric current is passed through any conducting solution are.</p> <p>i) Bubbles of gas can be formed on the electrodes and deposits of metal may also be seen on electrodes.</p> <p>ii) The solution may get heated.</p> <p>iii) There can be a change in the colour of the solution. (2m)</p> <p style="text-align: center;">OR</p> <p>Advantages:</p> <ul style="list-style-type: none"> ● It protects the metals from being corroded. ● It prevents the rusting of metals. ● It makes cheap and dull metals shiny and attractive. ● It can make more reactive metals like iron less reactive. ● Chromium coating on metals give lustre to objects. <p>Disadvantages</p> <ul style="list-style-type: none"> ● Pollutants from electroplating industries are very harmful. Some chemicals are very lethal for both humans and animals. ● It is an expensive process. 	5
	SECTION E	
19	<p>(a) Circuit is a closed path through which an electric current flow.</p> <p>(b) Deflection of compass needle shows that the current is flowing in the circuit. It is the magnetic effect of current.</p> <p>(c) The current flowing through the circuit in the first case was too low to make the bulb glow but adding a cell in the second case makes the bulb glow.</p> <p>(d) Ram is intelligent, helpful, analytical and with scientific aptitude.</p>	4
20	<p>(a) Definition of electroplating (2m)</p> <p>(b) Any two applications of electroplating with correct reasons(2m)</p>	4

CHAPTER 12- SOME NATURAL PHENOMENA

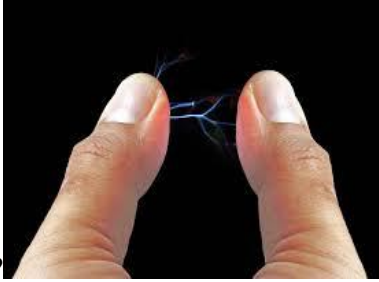
Q NO	SECTION A	MARKS
1	<p>Which of the following can not be charged easily by friction?</p> <p>a) a copper rod b) a plastic scale c) a woolen cloth d) an inflated balloon</p>	1
2	<p>Earthquakes of which magnitude of the following cause the maximum damage?</p> <p>(a) 3.0 (b) 8.0 (c) 5.0 (d) 4.0</p>	1
3	<p>Electric current has to be passed from one body to another. For this purpose, the bodies must be joined with a -</p> <p>(a) cotton thread. (b) plastic string. (c) copper wire (d) rubber band</p>	1
4	<p>Where should the lightning conductor be located?</p> <p>(a) In the bottom of the building (b) In the middle of the building (c) On the top of the building (d) Anywhere can be installed</p>	1
5	<p>Which of the statements is INCORRECT?</p> <p>(a) Earthquakes can occur any time anywhere over the world. (b) The earth's outer layer plates are always in continuous motion. (c) Earthquakes on the earth can not be caused by the eruption of a volcano. (d) The electric discharge process cannot occur between the cloud and the earth.</p>	1
6	<p>Which of the following is not likely to cause a tsunami?</p> <p>(a) Nuclear explosion under sea (b) Earthquake (c) Volcanic eruption (d) Lightning</p>	
7	<p>Assertion:Earthquakes are caused by the movement of plates. Reason:The boundaries of these plates are called seismic zones.</p> <p>a.Both assertion and reason are true and reason is the correct explanation of assertion. b.Both assertion and reason are true and reason is not the correct explanation of assertion c.Assertion is true and the reason is false. d.Assertion is false and reason is true</p>	1

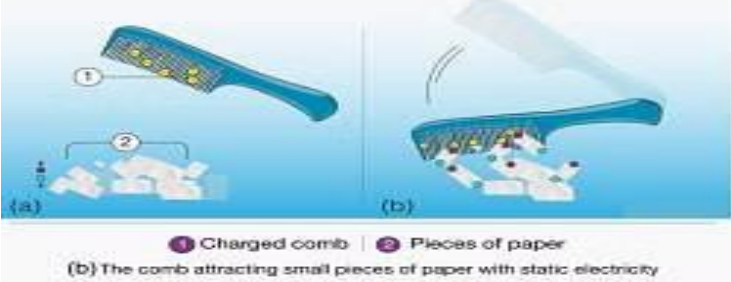
8	<p>Assertion- A person should not lie on the ground during lightning. Reason- Our body is a good conductor.</p> <ul style="list-style-type: none"> . Both assertion and reason are true and reason is the correct explanation of assertion. a. Both assertion and reason are true and reason is not the correct explanation of assertion b. Assertion is true and the reason is false. c. Assertion and reason are false 	1
SECTION B		
9	<p>During winter when we touch our friend after coming from sunlight we suddenly get current shock. Is it because we got electric current in our body or there is another reason?</p> 	2
10	<p>Why does aluminum foil in an electroscope come into its original position when touched by a person?</p>	2
11	 <p>https://images.app.goo.gl/CXk48Vyewc4WqEYX9</p> <p>Why should we take such positions or take shelter under tables during earthquakes?</p>	2
12	 <p>(b) The comb attracting small pieces of paper with static electricity</p> <p>Why are pieces of paper getting attracted towards comb?</p>	2
13	<p>Write the nature of the charges on a glass rod and silk cloth when they are rubbed with each other.</p>	2
SECTION C		
14	<p>How is lightning different from the short circuit we see at our home?</p>	3
15	<p>You are provided with two metal clips, cardboard pieces, a glass container and a charged metal rod. Design an activity using the above items to make an electroscope.</p>	3

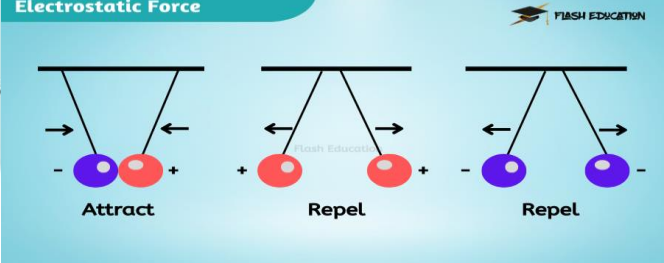
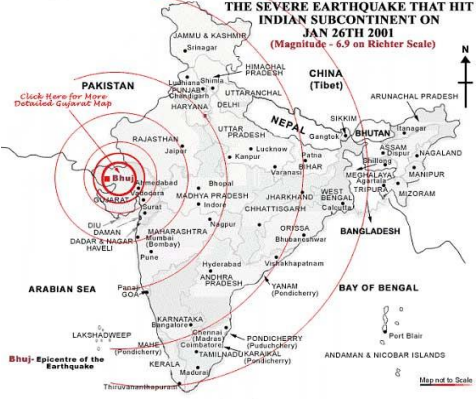
16	<p style="text-align: center;">Electrostatic Force</p>  <p>https://images.app.goo.gl/GVfGwe7BwdAwMQkj9</p> <p>Observe the figure and write what you have understood from these three cases.</p>	3
SECTION D		
17	<ol style="list-style-type: none"> Why should a building be protected with lightning conductors? What is the main principle of lightning conductor? If your building is not protected with the lightning conductor, what will you do when lightning strikes? 	5
18	<ol style="list-style-type: none"> What causes an earthquake? Why is central Himalaya considered a seismic zone of India? Which type of home should be made in seismic zones? 	5
SECTION E		
19	<p>Aman rubbed two balloons with a silk cloth, then he observed the following things-</p> <ol style="list-style-type: none"> Two balloons repel each other when brought closer. One balloon stacked to the wall for some time. <p>Now answer these questions-</p> <ol style="list-style-type: none"> What process happened during rubbing balloons with cloth? Why do two balloons repel? Why is one balloon attracted towards the wall? Name one device based on this concept? 	4
20	 <p>Observe the figure and answer the following questions-</p> <ol style="list-style-type: none"> When was the severe earthquake hit Bhuj (Gujrat)? Was its minor earthquake or a destructive one? Which type of place is mostly affected with earthquakes? What do you understand about epicenter? 	4

ANSWER KEY (CHAPTER 12: SOME NATURAL PHENOMENA)

Q NO	SECTION A	MARKS
1	a)	1
2	b)	1
3	c)	1
4	c)	1
5	c)	1
6	d)	1
7	b)	1
8	a)	1
SECTION B		
9	Yes, electric charge is formed most commonly in winters or when the climate around us is dry. The air becomes dry and electrons easily develop on the surface of our skin. During summer, the air moisture eradicates the negatively charged electrons and we rarely feel electric charge.	2
10	The strips carrying similar charges repel each other when given charge by an external body. Hence, they move apart in the electroscope. After some time, due to the electric discharge of the foil strips, they stop repelling each other. Hence, the strips come back to their initial position.	2
11	At the time of an earthquake, if people are trapped inside a house, the maximum possibility is that the roof of the building may fall. To handle this, people should take shelter under the bed or table, which would take the impact of roof fall and the chances of survival may increase.	2
12	The paper is attracted to the comb. This happens because the charged comb induces an opposite charge in the paper and as opposite charges attract, the paper sticks to the comb.	2
13	The fabric is negatively charged and the rod is positively charged.	2
SECTION C		
14	Lightning is a temporary flow of current, an electrical discharge. Electrons rush from where there are too many toward where there are too few. It is a bit like a short circuit between two differently charged bodies. A circuit is simply a path for electrons to flow.	3
15	Cover the glass jar with cardboard and make a small hole in it to insert a metal wire or a metallic paper clip. Attach two metal plates (like - aluminum foil leaves) on the end of the wire/paper clip which is inside the glass jar.	3
16	In the first figure bobs are getting attracted because they are having different charges. In the second and third figure bobs are repelling because they are having different charges.	3
SECTION D		
17	I. Lightning conductors do not allow the charge to accumulate on a building. It transfers all the charges to the earth, protecting the building from being struck by lightning II. The conductor works on the principle of induction. Whenever a charged cloud passes by the building, the conductor gets charge x opposite	1+2+2

	<p>to that of the cloud through the process of induction. Now, this acquired charge moves to the earth through the earthing system.</p> <p>III. *stay off corded phones, computers and other electrical equipment that put *you are in direct contact with electricity. Stay away from windows and doors, and stay off porches.</p>	
18	<p>I. Earthquakes occur due to sudden tectonic movements within the Earth's crust. The Earth's crust is divided into large sections called tectonic plates, which float on the semi-fluid layer known as the asthenosphere. These plates are constantly in motion</p> <p>II. The central Himalaya, considered as a prominent 'seismic gap', is generally believed to be the most vulnerable segment, due for a great plate boundary earthquake</p> <p>II. If possible, in earthquake prone areas, the houses should be made of wood. It would be better if the walls of such buildings do not touch the ground as was done by the ancient Japanese in building their temples or any other logically correct answer.</p>	2+1+2
19	<p>I. Rubbing the balloons against cloth causes the balloons to become electrically charged.</p> <p>II. Because they have the same charge.</p> <p>III. Because the balloon is charged and the wall is uncharged.</p> <p>IV. Electroscope</p>	1+1+1+1
20	<p>I. 26 Jan 2001</p> <p>II. Destructive one</p> <p>III. Most earthquakes occur along the edge of the oceanic and continental plates.</p> <p>IV. Epicenter is the location on the surface of the Earth directly above where the earthquake starts.</p>	1+1+1+1

CHAPTER 13- LIGHT

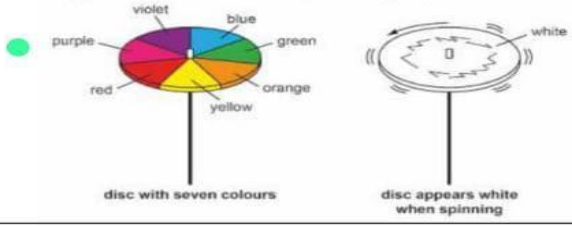
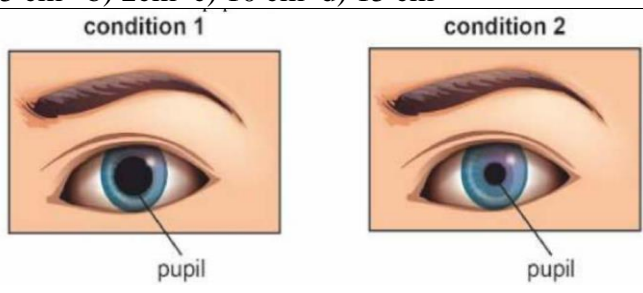
Q NO	SECTION A	MARKS
1	<p>Radha has a multi- coloured disc. She finds that the disc appears white when she spins it rapidly</p> <div style="text-align: center;">  <p>The diagram consists of two parts. On the left, a circular disc is divided into seven equal segments of different colors: violet, blue, green, yellow, orange, red, and purple. A label 'disc with seven colours' points to this disc. On the right, the same disc is shown spinning rapidly, indicated by curved arrows around its edge. The disc now appears as a single white circle. A label 'disc appears white when spinning' points to this disc.</p> </div> <p>What can be concluded from the picture?</p> <p>a) All spinning objects appear white b) All discs are multilayered c) Objects lose their colour on spinning . d) White is a mixture of seven different colours</p>	1
2	<p>Which of these objects is non luminous in nature?</p> <p>a) Sun b) Firefly c) Wood d) all the above</p>	1
3	<p>All object can only be seen when</p> <p>a) light emitted by object b) light pass from the object c) light completely absorb by the object d) Reflected light from the object reaches to us</p>	1
4	<p>Distance between the object and the image is 10 cm .What will be the distance between mirror and object ?</p> <p>a) 5 cm b) 2cm c) 10 cm d) 15 cm</p>	1
5	<div style="text-align: center;">  <p>The image shows two human eyes side-by-side. The left eye is labeled 'condition 1' and has a large, dilated pupil. The right eye is labeled 'condition 2' and has a small, contracted pupil. Both eyes have a label 'pupil' pointing to their respective pupils.</p> </div> <p>The picture above shows the size of the pupil under two different conditions</p> <p>a) condition 1 and 2 both shows dilation b) condition 1 shows dilation and condition 2 show contraction c) condition 1 shows contraction and Condition 2 shows dilation d) None of the above</p>	1
6	<p>Rama is focusing torch light perpendicularly on a plane mirror, what will be the angle in which it will be reflected?</p> <p>(a) 45 degrees (b) 90 degrees (c) 180 degrees (d) 360 degrees</p>	1

	<p>In the following questions , the Assertion and Reason have been put forward .Read the statements carefully and choose alternative from the following :</p> <p>(a) Both the Assertion and the Reason are correct and the Reason is the correct explanation of the Assertion .</p> <p>(b) The Assertion and the Reason are correct but the Reason is not the correct explanation of the Assertion .</p> <p>(c) Assertion is true but the Reason is false</p> <p>(d) The statement of the Assertion is false but the Reason is true.</p>	1
7	<p>Assertion : In the image formed by the plane mirror the right side of the object appears on the left side and vice versa.</p> <p>Reason : This is caused by the phenomenon called lateral Inversion.</p>	
8	<p>Assertion :Formation of rainbow shows seven colour in the sky</p> <p>Reason : Reflection is the phenomenon in which light scattered into different colours</p>	1
SECTION B		
9	<p>Ram while playing with his friends entered a dark room. Can they see objects in the room? Can they see objects outside the room? Analyse your answer based on the property of light</p>	2
10	<p>Shyam wanted to perform Activity using a laser torch on his eyes. His teacher advised him not to do so. Give justification for his teacher's advice?</p>	2
11	<p>Recommend 2 precautions to take care of your eyes</p>	2
12	<p>a) What will happen to the size of the pupil when we enter the dark room? b) Compare the number of cones to rods in nocturnal birds?</p>	2
13	<p>State the laws of reflection</p>	2
SECTION C		
14	<p>Compare regular and diffused reflection. Does diffused reflection defy the laws of reflection.</p>	3
15	<p>Mention against each of the following whether regular or diffused reflection will take place when a beam of light strikes. Justify your answer in each case.</p> <ol style="list-style-type: none"> 1. Polished wooden table 2. Chalk powder 3. Cardboard surface 4. Marble floor with water spread over it 5. Mirror 6. Piece of paper 	3

16	What is the angle of incidence of a ray if the reflected ray is at an angle of 90° to the incident ray	3
----	---	---

SECTION D

17	a) Ram went to the saloon to have his hair cut. Look at the figure. Can his image be obtained on a screen?	2
----	--	---



b) Write down the names of parts of the eye in the blank spaces shown in

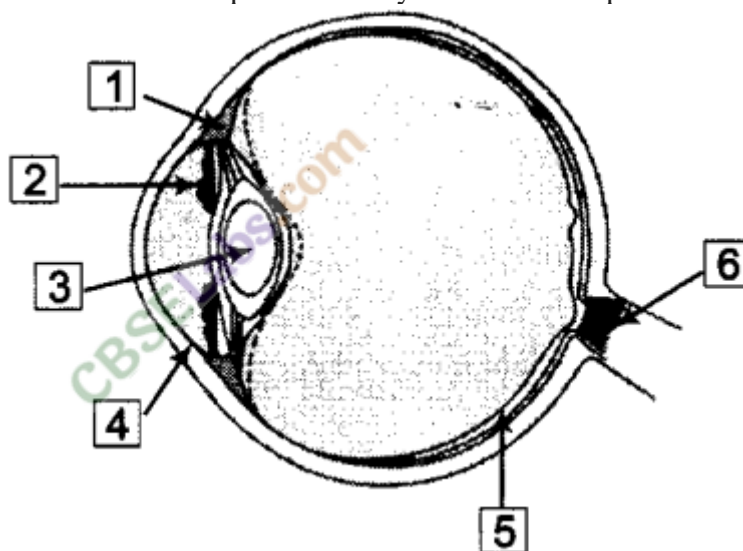

the figure.

18	a). Formulate the phenomenon of dispersion through rainbows.	2
	b) Can the reflected rays be further reflected if incident on another mirror?	1
	c) Name the instrument which shows multiple reflections used by designers and Why?	2

SECTION E

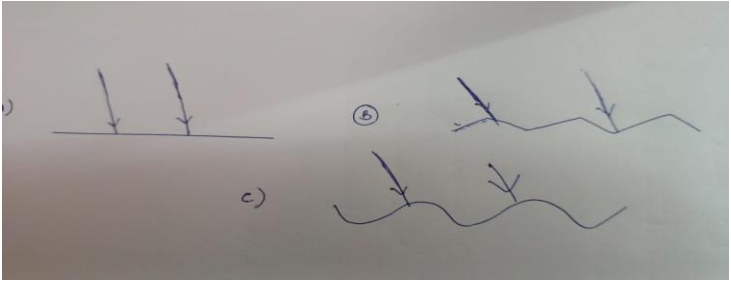
19	<p>Observe the following diagram fig A,B and C represent three situations, answer the following questions.</p>  <p>a) In which condition angle of incidence will be equal to angle of reflection . Justify your answer .</p> <p>b) Complete the fig A by drawing i) Position of plane mirror ii) Normal iii) angle of reflection.</p> <p>c) Differentiate between regular and irregular reflection.</p>	<p>2</p> <p>1</p> <p>2</p>
20	<p>Paheli conducts a survey in her society and finds out that nowadays many children wear spectacles as compared to 10 years back.</p> <p>a) What could be the possible reasons for weak eyesight in children?</p> <p>b) Discuss what measure to follow to take care of eyes (at least 2)</p> <p>c) Draw a well labelled diagram of the human eye.</p>	<p>2</p> <p>1</p> <p>2</p>

ANSWER KEY (CHAPTER 13- LIGHT)

Q NO	SECTION A	MARKS								
1	d) White is a mixture of seven different colours	1								
2	c) Wood	1								
3	d) Reflected light from the object reaches to us	1								
4	a) 5 cm	1								
5	b) condition 1 shows dilation and condition 2 show contraction	1								
6	b) 90 degrees	1								
7	a) Both the Assertion and the Reason are correct and the Reason is the correct explanation of the Assertion .	1								
8	c) Assertion is true but the Reason is false	1								
SECTION B										
9	When we are in a dark room then we cannot see objects in the room. We can see the objects outside the room, because out of the room the light is available and the rays of light can enter our eyes after reflection from the objects.	2								
10	The intensity of the laser light is very high which is harmful to the eye and can cause permanent damage to the eye. She can lose her eyesight also due to severe damage to the retina. Therefore, it is advisable not to look at a laser beam directly.	2								
11	I. Do not read in too little or too much light. ii. Wash your eyes frequently with cold water. iii. Do not read by bringing your book too close to your eyes or keeping it too far. iv. Never rub your eyes. Any 2 precautions can be given marks	2								
12	(a) enlarge (b) fewer	2								
13	2 laws of reflection	2								
SECTION C										
14	No, diffuse reflection doesn't mean the failure of laws of reflection. <table border="1" style="width: 100%; border-collapse: collapse;"> <thead> <tr> <th style="text-align: left; padding: 5px;">Regular Reflection</th> <th style="text-align: left; padding: 5px;">Diffused Reflection</th> </tr> </thead> <tbody> <tr> <td style="padding: 5px;">(i) All the reflected rays are parallel.</td> <td style="padding: 5px;">(i) The reflected rays are not parallel.</td> </tr> <tr> <td style="padding: 5px;">(ii) It occurs on a smooth and polished surface.</td> <td style="padding: 5px;">(ii) It occurs on the rough surface.</td> </tr> <tr> <td style="padding: 5px;">(iii) Reflected rays are in one direction.</td> <td style="padding: 5px;">(iii) Reflected rays are scattered in different directions.</td> </tr> </tbody> </table>	Regular Reflection	Diffused Reflection	(i) All the reflected rays are parallel.	(i) The reflected rays are not parallel.	(ii) It occurs on a smooth and polished surface.	(ii) It occurs on the rough surface.	(iii) Reflected rays are in one direction.	(iii) Reflected rays are scattered in different directions.	3
Regular Reflection	Diffused Reflection									
(i) All the reflected rays are parallel.	(i) The reflected rays are not parallel.									
(ii) It occurs on a smooth and polished surface.	(ii) It occurs on the rough surface.									
(iii) Reflected rays are in one direction.	(iii) Reflected rays are scattered in different directions.									
15	1. Regular reflection will take place because the surface is plane and polished. 2. Diffused reflection will take place because the surface is rough.	3								

	<p>3. Diffused reflection will take place because the surface is rough.</p> <p>4. Regular reflection will take place because the surface is smooth and plane.</p> <p>5. Regular reflection will take place because the surface is plane and polished.</p> <p>6. Diffused reflection will take place because the surface is rough.</p>	
16	<p>Here, the angle of reflection is 90°. As we know, according to the laws of reflection that angle of incidence is equal to angle of reflection.</p> <p>Here, the angle between the incident ray and reflected ray is 90°.</p> <p>i.e., $\angle i + \angle r = 90^\circ$</p> <p>Since, $\angle i = \angle r$</p> <p>We can write, $\angle i + \angle i = 90^\circ$</p> <p>$\Rightarrow 2\angle i = 90^\circ$</p> <p>$\Rightarrow \angle i = 45^\circ$</p> <p>Angle of incidence = 45°.</p>	3
SECTION D		
17	<p>(a). The image of the child cannot be obtained on the screen because the image is not real. The images formed by plane mirrors are virtual, so these virtual images cannot be seen (or obtained) on the screen.</p> <p>(b) The names of the parts of the eye as shown in the figure are:</p> <ol style="list-style-type: none"> 1. Ciliary muscle 2. Iris 3. Lens 4. Cornea 5. Retina 6. Optic nerve 	2 3
18	<p>(a) phenomenon of dispersion of light and formation of rainbow.</p> <p>(b) Yes, because of multiple reflections.</p> <p>(c) Kaleidoscope, because of multiple reflections it gives different patterns.</p>	2 1 1+1
SECTION E		
19	<p>a) In all the cases angle of incidence will be equal to angle of reflection because as per laws of reflection angle of incidence is equal to angle of reflection.</p> <p>b)</p>	2

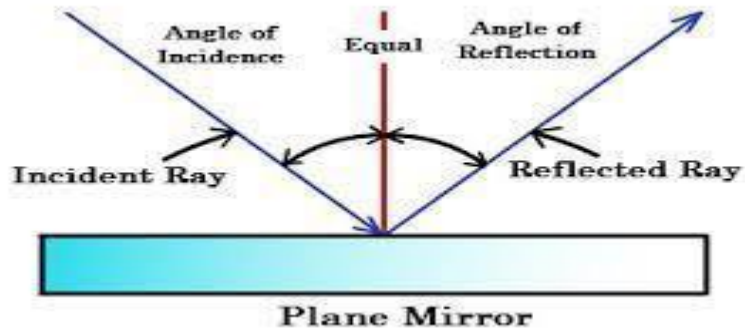

c) In regular reflection, light reflected from a smooth surface in a definite direction. In irregular reflection, light is reflected from a rough surface in all directions and not in a definite direction.

20

- a) Myopia or hypermetropia
- b) Eat a healthy, balanced diet. ...
Maintain a healthy weight.
Any 2
- c) Diagram + Labelling

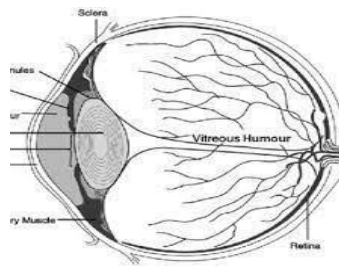

1

2

2

1

1+1

CLASS – VII

COMPETENCY BASED TEST ITEMS

TABLE OF CONTENTS

S.NO.	NAME OF THE CHAPTER	PAGE NO.
1	NUTRITION IN PLANTS	251
2	NUTRITION IN ANIMALS	255
3	HEAT	260
4	ACIDS, BASES AND SALTS	265
5	PHYSICAL AND CHEMICAL CHANGES	269
6	RESPIRATION IN ORGANISMS	274
7	TRANSPORTATION IN ANIMALS AND PLANTS	278
8	REPRODUCTION IN PLANTS	281
9	MOTION AND TIME	287
10	ELECTRIC CURRENT AND ITS EFFECTS	292
11	LIGHT	297
12	FORESTS: OUR LIFELINE	302
13	WASTEWATER STORY	307

CHAPTER 1: NUTRITION IN PLANTS

Q NO	SECTION A	MARKS
1	Where can we see Rhizobium bacteria? (a) Dead matter (b) Decaying matter (c) Both a and b (d) Root nodules leguminous plants.	1
2	The term that is used for the mode of nutrition in yeast (a) Autotrophic (b) Insectivorous (c) Saprophytic (d) Parasitic	1
3	Which of the following is not necessary for photosynthesis? (a) carbon dioxide (b) oxygen (c) sunlight (d) water	1
4	Which of the following traps sunlight? (a) chlorophyll (b) oxygen (c) sunlight (d) water	1
5	When iodine solution is added to starch it changes to (a) blue-black colour (b) blue-brown colour (c) reddish brown colour (d) blue-yellow colour	1
6	Which of the following is a parasite? (a) lichen (b) pitcher plant (c) cuscuta (d) rhizobium	1
	Question 7 and 8 given below consists of an assertion and a Reason. Use the following key to choose the appropriate answer. (a) Both A and R are true and R is the correct explanation of A. (b) Both A and R are true but R is not the correct explanation of A. (c) A is true but R is false. (d) A is false but R is true.	1
7	Assertion (A) : The green pigment present in the leaves of plants is called chlorophyll. Reason (R) : Sunlight is one of the essential conditions for photosynthesis to occur in plants.	
8	Assertion (A): The product of photosynthesis is a complex chemical substance called carbohydrate. Reason (R) : Leguminous plants absorb carbon dioxide from the soil	1
	SECTION B	

9	Differentiate between nutrients and nutrition.	2
10	Define photosynthesis along with the equation for the same.	2
11	What is the function of stomata in the leaves of a plant?	2
12	From where do the plants obtain nitrogen?	2
13	Draw a labelled diagram of a cell showing nucleus and cytoplasm.	2
SECTION C		
14	Give a brief description of the process of synthesis of food in green plants with a suitable diagram.	3
15	What is a saprotrophic mode of nutrition?	3
16	Name the following: (i) A parasitic plant with yellow, slender and branched stems. (ii) A plant that is partially autotrophic. (iii) The pores through which leaves exchange gases.	3
SECTION D		
17	a) How are nutrients replenished in the soil? b) Name any two nitrogen fixing organisms.	5
18	a) How would you test the presence of starch in leaves? b) In which form carbohydrates are stored in plants?	5
SECTION E		
19	The leaves other than green in colour also have chlorophyll. The large amount of red, brown and other pigments masks the green colour. Photosynthesis takes place in these leaves also. Answer the following: 1. What is the colour of algae? 2. Where does the synthesis of food take place? 3. Differentiate between autotrophic nutrition and autotrophs.	4
20	Take a piece of bread and moisten it with water. Leave it in a moist warm place for 2–3 days or until fluffy patches appear on them.  Answer the following: 1. What are the organisms growing on this bread? 2. How do fungi reproduce? 3. What is saprotrophic nutrition?	4

ANSWER KEY (CHAPTER 1: NUTRITION IN PLANTS)

Q.No	SOLUTION	MARK
1	(d)	1
2	(c)	1
3	(b)	1
4	(a)	1
5	(a)	1
6	(c)	1
7	(b)	1
8	(c)	1
9	Carbohydrates, proteins, fats, vitamins and minerals are essential components of food, these components are called nutrients, but Nutrition is the mode of taking food by an organism and its utilization by the body.	2
10	Photosynthesis is the food manufacturing process of green plants containing chlorophyll, in presence of sunlight, with the help of carbon dioxide and water to synthesize carbohydrates. The equation for the process is as follow: IN THE PRESENCE OF SUNLIGHT Carbon dioxide + water \longrightarrow carbohydrate + Oxygen	2
11	Stomata are the tiny pores present on the surface of leaves which helps in exchange of gases and transpiration.	2
12	Soil has certain bacteria that convert gaseous nitrogen into a usable form and release it into the soil. These soluble forms are absorbed by the plants along with water. By adding fertilizers rich in nitrogen to the soil farmers also made nitrogen available for plants.	2
13	NCERT TEXT BOOK Page No:2 Fig No.1.1	2
14	Photosynthesis is the food manufacturing process of green plants containing chlorophyll, in presence of sunlight, with the help of carbon dioxide from the atmosphere and water from the soil to synthesize carbohydrates. Diagram-Page No.3 Fig. No. 1.3	3
15	This mode of nutrition in which organisms take in nutrients in solution form from dead and decaying matter is called saprotrophic nutrition. Plants which use saprotrophic mode of nutrition are called saprotrophs. Example: Fungi that secrete digestive juices on the dead and decaying matter and convert it into a solution. Then they absorb the nutrients from it.	3
16	I. Cuscuta Ii Pitcher plant Iii Stomata	3
17	(a) 1. Growing a leguminous plant (that can fix atmospheric nitrogen with the help of rhizobium bacteria). 2. Mixed cropping, 3. Crop rotation, 4. Field fellow 5. Making compost, 6. Vermicomposting. (Any five)	3
	(b) Blue green algae, Rhizobium (any other example)	2

18	(a) Take two potted plants of the same kind. Keep one in the dark for 72 hours and the other in sunlight. Now leave the pot which was earlier kept in the dark, in the sunlight for 3 – 4 days and perform the iodine test on its leaves. By putting them in hot water and in alcohol in a water bath and by adding a few drops of iodine solution on them. If they change into blue black color it indicates the presence of starch. (b) Starch	4 1
19	A. Colour of algae depends on the type of pigment present in it. it can be green, blue-green, brown, golden etc B. In leaves C. The organisms which prepare their food themselves are called autotrophs and this mode of nutrition is called autotrophic nutrition.	1 1 2
20	1. Fungi 2. By spores 3. The mode of nutrition in which organisms take in nutrients from dead and decaying matter is called saprotrophic nutrition.	1 1 2

CHAPTER 2 : NUTRITION IN ANIMALS

Q NO	SECTION A	MARKS
1	<p>_____ part of the alimentary canal receives secretions from the liver and the pancreas.</p> <ol style="list-style-type: none">Large intestinestomachsmall intestineoesophagus	1
2	<p>Some food items are listed below.</p> <ol style="list-style-type: none">Boiled riceGheePotatoVegetable oil <p>Which of the above food items gave a positive iodine test.</p> <ol style="list-style-type: none">i onlyii and iiii and ivi and iii	1
3	<p>Vikash is suffering from hepatitis B. His doctor advised him not to take any oily food item? Which part of the digestive system is infected in Vikash?</p> <ol style="list-style-type: none">stomachliversmall intestinepancreas	1
4	<p>_____ is the widest part of the alimentary canal.</p> <ol style="list-style-type: none">Small intestineliverlarge intestinestomach	1
5	<p>Full form of ORS</p> <ol style="list-style-type: none">Oral rehydration solutionOral reserve solutionObvious rehydration solutionOral recycle solution	1
6	<p>Cud can be defined as</p> <ol style="list-style-type: none">Swallowed and completely digestedChewed and partially digestedSwallowed and partially digestedChewed and completely digested	1
7	<p>How many incisor teeth are found in the lower jaw of human beings?</p> <ol style="list-style-type: none">6438	1

8	<p>Question 8 consists of two statements – Assertion (A) and Reason (R). Answer these questions selecting the appropriate option given below:</p> <p>(a) Both A and R are true and R is the correct explanation of A. (b) Both A and R are true but R is not the correct explanation of A. (c) A is true but R is false. (d) A is false but R is true.</p> <p>Assertion: Fats present in goat's milk are found to be simple or less complex as compared to cow's milk. Reason: Cow's milk is difficult to digest than goat milk</p>	1								
SECTION B										
9	Boojho and Paheli are playing with their friends. They took three juices. Juice A is sugar cane, juice B is lemonade and juice C is bitter gourd juice. Boojho is blindfolded by his friends and asked to identify types of juices. Could you help Boojho in identifying the juices?	2								
10	Make a flow chart showing organs of the human alimentary canal in sequence that food follows for the digestion process.	2								
11	Is there any difference between digestive system and digestive tract? If yes, justify.	2								
12	<p>Fill the following Blanks;</p> <table border="1" style="width: 100%; border-collapse: collapse;"> <thead> <tr> <th style="width: 50%;">Name of complex component of food</th> <th style="width: 50%;">Simpler form</th> </tr> </thead> <tbody> <tr> <td>Carbohydrate</td> <td>_____</td> </tr> <tr> <td>_____</td> <td>_____+Glycerol</td> </tr> <tr> <td>Proteins</td> <td>_____</td> </tr> </tbody> </table>	Name of complex component of food	Simpler form	Carbohydrate	_____	_____	_____+Glycerol	Proteins	_____	2
Name of complex component of food	Simpler form									
Carbohydrate	_____									
_____	_____+Glycerol									
Proteins	_____									
13	Villi are richly supplied with blood vessels. Why?	2								
SECTION C										
14	<p>“The saliva breaks down the starch into sugars”.</p> <p>Explain an activity to prove the above statement. Write all the steps involved in the activity. (hint: Aim, material required, procedure, observation and conclusion)</p>	3								
15	It is usually advised by the parents not to talk while having food. Do you think there is any scientific reason behind it? If yes, justify.	3								
16	What is assimilation? Illustrate the significance of assimilation in the process of nutrition.	1 +2								
SECTION D										
17	<p>I. Name associated glands found in the human digestive system. II Observe the diagram and label associated glands.</p>	5 (1.5+1.5+2)								

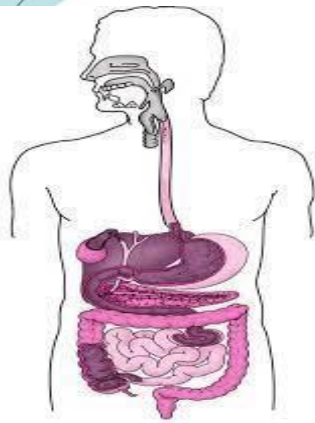

NCERT, Class VII (Page no. 12)

iii. Fill the following table

S.no.	Name of the associated gland	Secretion
1		
2		
3		

- 18
- i) Draw a well labelled diagram showing nutrition in amoeba. (At Least 4 labels)
- ii A woman stuck into a forest for a few days and started eating grass to remain alive. In your opinion, will she be able to survive in the forest? Discuss

5

SECTION E

- 19
- Hina joined the gym recently after her surgery. Her gym instructor gave her a diet plan to be strictly followed for weight loss.
- Which components of food occupy the maximum portion of the diet?
 - What changes in the digestion process takes place after the surgery.
 - Hot water intake also advised to increase? Why?

4

- 20
- Read the passage and answer the following question:
- Ram is a 12-year-old boy who wants to have good height as he loves to play volleyball and wants to get selected in the school's volleyball team. His parents and teachers suggested that he include bodybuilding food (protein rich food) in his diet. Ram started taking an appropriate amount of protein rich food such as milk, eggs, pulses, soybean, etc. Even after taking food regularly he was not getting expected results. He visited a doctor and the doctor told him that there is a problem found in the digestion of protein.

4

	<p>a) Analyse the situation of Ram and enlist the possible reasons for his diagnosis. (2)</p> <p>b) Inner lining of the stomach is very delicate. In Spite of the presence of HCl, it will not get damaged. Why? (1)</p> <p>c) Write any two functions of HCl. (1)</p>	

ANSWER KEY (CHAPTER 1: NUTRITION IN ANIMALS)

Q. NO.	SOLUTION	MARKS
1	c)	1
2	d)	1
3	b)	1
4	d)	1
5	a)	1
6	c)	1
7	b)	1
8	b)	1
9	<ul style="list-style-type: none"> Boojho can identify the drinks by tasting the juices with the help of taste buds present in the tongue. All the three juices have different tastes such as sweet (sugar cane juice), sour (lemonade) and bitter (bitter gourd). 	1 1
10	<ul style="list-style-type: none"> Any four organ in sequence Flow chart showing correct sequence of all 6 parts 	1 2
11	<ul style="list-style-type: none"> Yes Digestive tract and associated glands together forms the digestive system. Hence the digestive tract is a part of the digestive system. 	1 1
12	Glucose, fats, fatty acids, amino acids (from first to last)	0.5 marks for each correct response
13	<p>Villi absorbs the digested food materials from the small intestine, transporting them via blood vessels to different parts of the body for normal growth and development.</p> <p>Rich blood supply helps villi to perform its function efficiently otherwise even after the proper digestion process sufficient amount of nutrients will not reach the targeted organs.</p>	1 1
14	<ul style="list-style-type: none"> Take a piece of bread and chew it slowly for 2 minutes Take out the food from your mouth and add iodine solution. 	1 2 3

	<ul style="list-style-type: none"> The blue black color will not appear as some of the starch gets converted into sugar by the action of saliva. 	
15	<ul style="list-style-type: none"> Yes The food particle can enter into windpipe and cause inconvenience Food particles can enter into the windpipe as it runs adjacent to the food pipe and share a common passage. It can cause choking, hiccups or coughing. 	1 1 2
16	<p>Assimilation is the process in which digestive food material is transported to different organs where they are used for normal growth and development of the body.</p> <p>Without the assimilation process growth and development of body parts is not possible. Entire process of digestion goes in vain and the process of synthesizing complex molecules from absorbed digestive materials will not take place.</p>	1 2
17	<p>i. Salivary gland, liver and pancreas</p> <p>ii. Correct labelling</p> <p>iii. Any two correct pair</p> <p>All correct</p>	1.5 (0.5 mark each) 1.5 1 (partial) 2 (full mark)
18	<p>.Page no. 18; fig 2.10 NCERT Diagram 4 label</p> <p>She will not be able to survive as grass contains cellulose, a type of carbohydrate which cannot be digested by human beings. She may develop some digestive issues causing vomiting and also weakness because of insufficient supply of nutrients in the body.</p>	1 (0.5 mark each) 2
19	<p>a) Protein and dietary fibre.</p> <p>b) There will be problems in digestion of fat as gallbladder stores bile juice and supplies it whenever required by the body for digestion of fats.</p> <p>c) Hot water will increase the rate of digestion.</p>	1 2 1
20	<p>ANY TWO</p> <p>a) *Genetic factors *Presence of worms that take up all the nutrition. (any other relevant reason)</p> <p>b) Inner lining of the stomach secretes mucus which forms a protective layer around the inner lining and protects it from HCl.</p> <p>c)HCl kills bacteria that enter in the body along with the food. Maintain acidic medium in stomach for smooth functioning of digestive juices.</p>	2 1 1

CHAPTER 3: HEAT

Q.NO.	QUESTION	MARKS
Section A		
1.	Land breeze blows during _____ a. Day time b. Night time c. Anytime d. None of the above	1
2.	Sea breeze blows during _____ a. Day time b. Night time c. Anytime d. None of the above.	1
3.	We see that wooden spoons are used to cook in many places. Why? a. Good conductor b. Bad conductor c. Both a) and b) d. None of the above	1
4.	Utensils made of metals can be used for cooking. Why? a. Becomes hot due to conduction b. Becomes hot due to convection c. Does not become hot d. Both a and b	1
5.	Kink is found in _____ - a. Clinical thermometer b. Laboratory thermometer c. both a and b d. None of the above.	1
6.	Convection generally occurs through _____ a) Liquids and gases b) Solids, Liquids and gases c) Solids and gases. d) Liquids and Solids.	1
7.	We should not touch an electric socket with plain metal screw driver without any plastic covering because _____ a. Metal is good conductor of heat b. Metals are bad conductors of heat. c. Both a and b d. None of the above.	1
8.	Assertion (A): movement of heat is always from higher temperature to lower temperature. Reason (R): Conduction, convection and radiation are three major mode of heat transfer	1
SECTION B		
9.	Mention the range of laboratory thermometer and clinical thermometer.	2

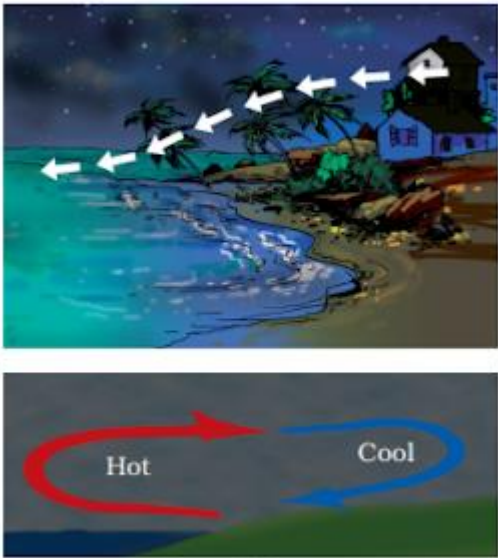
10.	Define temperature. How is it measured?	2
11.	Why should we not use a clinical thermometer to measure the temperature of the other objects?	2
12.	Define a) Conductors b) Insulators	2
13.	Justify the statement “We wear light- coloured clothes in Summer and dark -coloured clothes in winter”. (2 points)	2
SECTION C		
14.	What are the three methods by which heat is transferred from one medium to another. Explain.	3
15.	Give a reason. Mercury does not fall or rise in a clinical thermometer when taken out of the mouth.	3
16.	Differentiate between clinical thermometer and laboratory thermometer.	3
SECTION D		
17	Create and write an activity to show that metals are good conductors of heat.	5
18	Sheela is planning to go to Shimla in December-January month. Suggest her clothes to be carried and justify your answer.	5
SECTION E		
19.	<p>The people living in the coastal areas experience an interesting phenomenon. During the day, the land gets heated faster than water. The air over the land becomes hotter and rises up.</p> <p style="text-align: center;">Night time</p>  <p style="text-align: center;">Land Breeze</p> <p>https://www.evidyarthi.in/wp-content/uploads/2020/03/class7-heat-ncert-notes-ch4-land-breeze.png</p> <p>a. Mention the mode of heat transfer. b. Name the type of breeze flowing in the Day time. c. Mention the movement of hot and cool air in the above picture.</p>	4

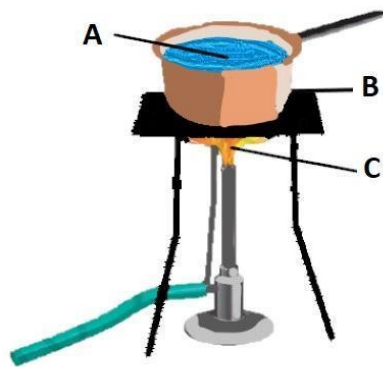

Figure 1 attribute NCERT

TEXTBOOK PAGE NO.46

Rina was boiling water, with potassium permanganate (KMnO_4) crystal placed inside. She observed the phenomena as shown in the above picture.

Now answer the following on your reading of the paragraph.

- What is the phenomenon going on inside the water in the vessel? Explain.
- In which other states of matter, other than liquids, do the above phenomena take place?
- Mention the phenomenon marked by A, B and C.

ANSWER KEY (CHAPTER 3: HEAT)

Q.NO.	ANSWERS	MARKS
SECTION A		
1	b)	1
2	a)	1
3	b)	1
4	a)	1
5	a)	1
6	a)	1
7	a)	1
8	b)	1
SECTION B		
9	Clinical thermometer reads temperature from 35 °c to 42 °c. Laboratory thermometer range is from -10 °C to 110 °C.	2
10	A reliable measure of the hotness of an object is its temperature. Temperature is measured by a device called Thermometer.	2
11	A clinical thermometer consists of a narrow range which makes it unsuitable for any other use.	2
12	The materials which allow heat to pass through them are called conductors of heat. Example- Iron, aluminium, copper, stainless steel, Gold, Silver etc. The materials which do not allow heat to pass through them easily are called insulators. Examples- Plastic, wood, paper etc	2
13	Dark surfaces absorb more heat and, therefore, we feel comfortable with dark coloured clothes in winter. Light coloured clothes reflect most of the heat that falls on them and, therefore, we feel more comfortable wearing them in summers.	2
SECTION C		
14	The three methods by which heat is transferred to one medium to another are: Conduction, Convection and Radiation. Conduction---- The process by which heat is transferred from the hotter end to the colder end of an object is known as conduction. Occurs generally in solids. Convection----- Hot water/air rises up and cold water/air comes down and the whole heating process goes on till full water/air gets heated up. This is known as convection. Radiation----- The transfer of heat in the form of heat rays as it comes from the sun for example is Radiation.	3
15	A kink near the bulb of a clinical thermometer prevents mercury from falling or raising when taken out of the mouth.	3
16		3

	CLINICAL THERMOMETER	LABORATORY THERMOMETER	
	It is used to measure the temperature of the human body.	It is used to measure the temperature of other objects.	
	Its range is from 35 degree Celsius to 42 degree Celsius.	Its range is from -10 degree Celsius to 110 degree Celsius.	
	It contains kink.	It does not contain kink	
SECTION D			
17	Any appropriate activity suitable for the given question.		5
18	Sheela should carry woolen clothes with her to Shimla while going in the months December and January. As, wool is a poor conductor of heat. Moreover, there is air trapped in between the wool fibers. This air prevents our body the flow of heat from our body to the cold surroundings		5
SECTION E			
19	a. Convection b. Sea breeze c. Hot air from sea to land cool air from land to sea.		1 1 2
20	a. Convection. In convection Hot water raises up and cold water from above comes down and gets heated up while heating and then raises up. Like this cycle continues. b. Gases. c. A is convection B is conduction C is radiation		1 1 2

CHAPTER 4: ACIDS BASES AND SALTS

Q. No.	SECTION A	MARKS												
1	Which group of substances has acidic nature? I Curd, lemon juice, orange juice and vinegar II Sugar, honey, jaggery and egg III Baking soda, soap, milk of magnesia and lime water IV vinegar, lemons, curd and tomato sauce a. I only b. II and III c. I and IV d. IV only	1												
2	In neutralization reaction the product along with salt is a. Oxygen b. Carbon dioxide c. Water d. iodine	1												
3	Ajay was testing the nature of some substances using hibiscus flowers as an indicator. Based on his results, complete the following table. <table border="1" style="margin-left: 20px; margin-top: 10px;"> <tbody> <tr> <td style="text-align: center;">I</td> <td style="text-align: center;">Lemon juice</td> <td style="width: 30px;"></td> </tr> <tr> <td style="text-align: center;">II</td> <td style="text-align: center;">Lime water</td> <td></td> </tr> <tr> <td style="text-align: center;">II</td> <td style="text-align: center;">Coffee</td> <td></td> </tr> <tr> <td style="text-align: center;">I</td> <td></td> <td></td> </tr> </tbody> </table> a. Dark pink, green, dark pink b. Green, dark pink, dark pink c. Dark pink, green, green d. Green, dark pink, green	I	Lemon juice		II	Lime water		II	Coffee		I			1
I	Lemon juice													
II	Lime water													
II	Coffee													
I														
4	Which acid is present in ant bites? a. Oxalic acid b. Lactic acid c. Formic acid d. Ascorbic acid	1												
5	Which is not a natural indicator? a. Litmus b. Phenolphthalein c. Beetroot d. hibiscus	1												
6	The reaction between an acid and a base is known as a. Absorption b. Assimilation c. Neutralisation d. Rumination	1												
7	The solution which do not change colour of a litmus solution is known as a. Indicator	1												

	<p>b. Neutral</p> <p>c. Phenolphthalein</p> <p>d. Lichens</p>	
8	<p>Following question consists of two statements – Assertion (A) and Reason (R). Answer these questions selecting the appropriate option given below:</p> <p>(a) Both A and R are true and R is the correct explanation of A.</p> <p>(b) Both A and R are true but R is not the correct explanation of A.</p> <p>(c) A is true but R is false.</p> <p>(d) A is false but R is true.</p> <p>Assertion: Ant bites caused irritation in the skin Reason: Ant stings inject formic acids in the skin</p>	1
SECTION B		
9	<p>Three guests have come over Joseph's house but his mother is not there. Some bottles of soft drink are kept in the fridge but they are not labelled. Now he has to serve the guests according to their choices. One guest wants an acidic drink, another wants basic and the third one wants a neutral drink. How will Joseph decide which drink is to be served to whom?</p>	2
10	<p>Seema added dilute sulphuric acid to lime water and touched the apparatus just after mixing them. How did she feel and why?</p>	2
11	<p>Write the reaction of neutralization with its reactants and products.</p>	2
12	<p>The factory waste should be treated before disposal into water bodies. Evaluate the consequences if waste is disposed of without treatment.</p>	2
13	<p>Devika was having stomach ache and acidic burps. Her mother gave her a solution to drink which relieved her discomfort. Justify her mother's solution to this situation.</p>	2
14	<p>Explain the following: -</p> <p>a. While performing a neutralisation reaction the test tube becomes hot.</p> <p>b. While washing clothes the area where curry was spilled turns red.</p>	3
15	<p>To get a higher yield, farmers use lots of chemical fertilizers nowadays. Write your views on whether they are doing right or wrong and why?</p>	3
16	<p>A farmer unhappy with the quantity of harvest he produced went to a krishi vigyan kendra and had the soil of his farm tested. If you were the specialist what you have suggested the farmer?</p>	3
SECTION C		
17	<p>Prepare a natural indicator with the help of an easily available substance. Write the steps and test the nature of tamarind juice. Write the observations.</p>	5
18	<p>a. A substance X most commonly used as a natural indicator. It has a purple colour in distilled water. when added to an acidic solution, its colour changed. What is substance X and which colour is seen after acidic solution is added to it.</p> <p>b. Write the source from where substance X is obtained?</p> <p>c. If solid baking soda is used on dry turmeric powder. Do you think it will change the colour of turmeric powder? Justify.</p>	5

SECTION E

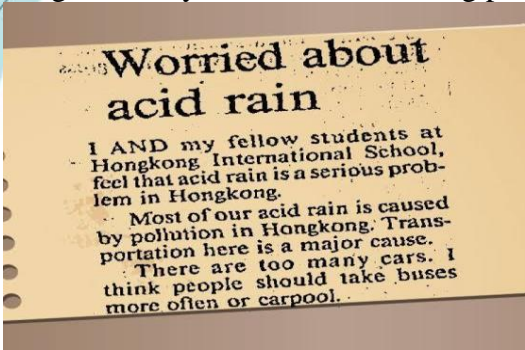
19	<p>image courtesy: south china morning post, Jan 16 2017</p>  <p>Worried about acid rain</p> <p>I AND my fellow students at Hongkong International School, feel that acid rain is a serious problem in Hongkong.</p> <p>Most of our acid rain is caused by pollution in Hongkong. Transportation here is a major cause. There are too many cars. I think people should take buses more often or carpool.</p>	
	<p>Answer the following questions</p> <p>a. Connect the phenomenon of acid rain with the fading of colour of Taj mahal.</p> <p>b. What could be the cause of acid rain?</p> <p>c. Suggest two ways to counter acid rain.</p>	<p>1</p> <p>1</p> <p>2</p>
20	<p>Our stomach contains hydrochloric acid. It helps us to digest food. But too much acid in the stomach causes indigestion. Sometimes indigestion is painful. To relieve indigestion, we take an antacid such as milk of magnesia which contains magnesium hydroxide. It neutralizes the effect of excessive acid. [ncert excerpt]</p> <p>a. In place of milk of magnesia can you suggest other medicine to neutralize the acid in acidic burps?</p> <p>b. Define neutralization.</p> <p>c. Analyse decaying of teeth in this context.</p>	<p>2</p> <p>1</p> <p>1</p>

ANSWER KEY (CHAPTER 4: ACIDS BASES AND SALTS)

Q. No.	SECTION A	
1	c	1
2	c	1
3	a	1
4	c	1
5	b	1
6	b	1

7	b	1
8	a	1
9	Joseph can decide with the help of litmus paper; i.If the drink turns a red litmus blue will be basic ii.If the drink turns a blue litmus to red will be acidic iii.If none of the litmus paper is changing its color then it's a neutral drink	2
10	The apparatus was hot. During neutralization heat evolves.	2
11	Acid + base \rightarrow salt + water Reactant - Acid + Base Product- Salt + Water	2
12	Water Bodies will have too much acid causing aquatic flora and fauna to die.	2
13	Acid burps are due to excessive acid in stomach which causes discomfort. As the solution relieved the pain it must have neutralized the acid which is a correct thing to do.	2
14	a) Neutralisation reaction evolves heat causing the test tube to become hot b) Curry contains turmeric which is a natural indicator and changes itself from yellow to red when mixed with a base. Soap solution is basic in nature.	3
15	Excess use of chemical fertilizers makes the soil acidic which in turn makes it infertile.	3
16	Based on the result of nature of soil, if it is acidic I would suggest to treat the field with slaked lime and if soil is basic, add organic matter to the field.	3
17	1. Pluck a hibiscus flower. 2. crush it with mortar and pestle. 3. add water and sieve the juice in a cup. Add some drops of tamarind juice in the prepared hibiscus juice. if the magenta color appears it is an acidic sample.	5
18	a. X – litmus ; red b. lichen c. No it won't change the color. Only in water solution a base or an acid behaves as a base or an acid respectively.	2 1 2
19	a. Acid present in acid rain reacts with the lime stone of Taj mahal which is basic in nature and the white color of stone is slowly fading away. b. Pollutants like Sulphur dioxide and nitrogen dioxide from automobiles exhaust and factories exhaust mixes with rain water to form acids like sulphuric acid and carbonic acid. These acids in the rain cause acid rain. c. Plantation, use of CNG (ANY OTHER REASON)	1 2 1
20	a. Baking soda (any other) b. The reaction between acid and a base is known as neutralization. c. Food debris causes bacterial growth. Bacteria form acids which react with enamel of teeth causing tooth decay.	1 1 2

CHAPTER 5: PHYSICAL AND CHEMICAL CHANGE

Q NO	SECTION A	MARKS
1	Which of the following is the chemical changes? a. Dissolving sugar in water. b. Beating of aluminium to make aluminium foil. c. Digestion of food. d. Cutting a log of wood into pieces	1
2	Which of the following is not the chemical change? a. Burning of coal b. Melting of wax c. Digestion of food d. Beating aluminium to make aluminium foil	1
3	A chemical change includes a. Change in colour. b. Change in odour. c. Change in temperature. d. All of the above.	1
4	In the process of galvanization iron is coated with a. Aluminium b. Gold c. Silver d. Zinc	1
5	Which of the following condition are not required of rusting of iron a. Presence of air b. Presence of moisture c. Presence of carbon dioxide d. None of the above.	1
6	When you cut a piece of apple and keep it away for some time. What will you observe a. There is a change in colour due to chemical change. b. There is no change in colour due to chemical change. c. There is a change in colour due to physical change. d. There is no change in colour due to physical change.	1
7	Directions: - The question below consists of an Assertion (A) and a Reason(R). Use the following key to choose the appropriate answer. a. Both A and R are true and R is the correct explanation of A. b. Both A and R are true and R is not the correct explanation of A. c. A is true but R is false. d. A is false but R is true.	1

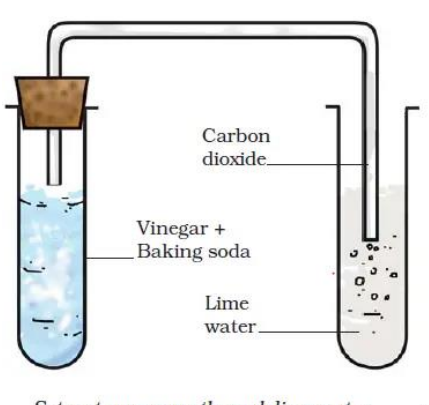
	Assertion (A): Change of water from liquid to ice on cooling is a physical change. Reason (R): Water cannot be changed steam.	
8	Assertion (A): Rusting is a chemical change. Reason (R): Rusting of iron requires air and water.	1
SECTION B		
9	Write two examples each of physical and chemical.	2
10	Give two examples for each of the following cases: - a. Physical changes are not reversible. b. Physical changes are reversible	2
11	What is crystallization?	2
12	Explain why burning of wood and cutting of wood are considered to be different types of changes.	2
13	Write the difference between physical and chemical changes.	2
SECTION C		
14	Observe the given activity and answer the following questions: -  a. Which gas is produced when baking soda is added to vinegar? b. What type of changes will you observe in the lime water and why?	3(1+2)
15	Give two examples each of the following cases:- a. Chemical changes when heat and light is produced? b. Chemical changes when sound is produced. c. Chemical changes where colour change takes place.	3
16	“Chemical changes are very important in our life.” Justify the statement with two examples.	3
SECTION D		
17	a. What are chemical changes? Explain with the help of an example? b. Write different characteristics of chemical changes.	5(2+3)
18	Take three glass bottles with wide mouths. Label them A, B and C. Fill about half of bottle A with ordinary tap water. Fill bottle B with water	5

	<p>which has been boiled for several minutes, to the same level as in A. In bottle C, take the same boiled water and of the same amount as in other bottles. In each bottle put a few similar iron nails so that they are completely under water. Add a teaspoonful of cooking oil to the water in bottle C so that it forms a film on its surface. Put the bottles away for a few days. Take out nails from each bottle and observe them. Explain your observation.</p>	
	SECTION E	
19	<p>Get a small piece of a thin strip or ribbon of magnesium. Clean it's tip with sandpaper. Bring the tip near a candle flame. It burns with a brilliant white light. When it is completely burnt it leaves behind a powdery ash. Does the ash look like magnesium ribbon? The change can be represented by the following equation: Magnesium (Mg) + Oxygen (O₂) → Magnesium oxide (MgO)</p> <ol style="list-style-type: none"> What type of changes are shown in the above activity? Identify the powdery ash produced? Why is its tip cleaned with sandpaper? 	4(1+1+2)
20	<p>A change with which you are quite familiar is the rusting of iron. If you leave a piece of iron in the open for some time, it acquires a film of brownish substance. This substance is called rust and the process is called rusting. Iron gates of parks or farmlands, iron benches kept in lawns and gardens, almost every article of iron kept in the open gets rusted. At home you must have seen shovels and spades getting rusted when exposed to the atmosphere for some time. In the kitchen, a wet iron pan (tawa) often gets rusted if left in that state for some time.</p> <ol style="list-style-type: none"> Observe and identify the type of changes that take place? What is meant by the process of rusting? What is the brownish substance called? Write different ways to prevent it? 	4(1+1+2)

ANSWER KEY (CHAPTER 5: PHYSICAL AND CHEMICAL CHANGES)

Q.NO.	SOLUTION	MARKS						
1	C) Digestion of food	1						
2	d) Beating aluminium to make aluminium foil	1						
3	d) All of the above	1						
4	d) Zinc	1						
5	c) Presence of carbon dioxide	1						
6	a) There is a change in colour due to chemical change.	1						
7	c) A is true but R is false.	1						
8	a) Both A and R are true and R is the correct explanation of A.	1						
9	Physical Changes: - cutting of trees, cutting of paper, Chemical Changes: - burning of wood, digestion of food	2						
10	Give two examples for each of the following cases: - a. Physical changes are not reversible: - cutting of wood, cutting of paper b. Physical changes are reversible: - melting of ice, dissolving of sugar in water.	2						
11	Crystallisation is the process of formation of solid crystals from solution, melt or by deposition directly from a gas phase.	2						
12	The burning of the wood is a chemical change as after burning wood changes into ash and produces light. Cutting of wood is a physical change as it involves only changes in the physical properties of wood that is change in the size of wood.	2						
13	<table border="1" style="width: 100%; border-collapse: collapse;"> <tr> <td style="width: 50%;">Physical changes</td> <td style="width: 50%;">Chemical changes</td> </tr> <tr> <td>Changes are reversible</td> <td>Changes are irreversible</td> </tr> <tr> <td>No new product is formed</td> <td>New products are formed</td> </tr> </table> <p>(any other reason)</p>	Physical changes	Chemical changes	Changes are reversible	Changes are irreversible	No new product is formed	New products are formed	2
Physical changes	Chemical changes							
Changes are reversible	Changes are irreversible							
No new product is formed	New products are formed							
14	a. Carbon dioxide b. It is a chemical change. Lime water turns milky because carbon dioxide reacts with lime water to form calcium carbonate	3(1+2)						
15	Give two examples each of the following cases:- a. Chemical changes when heat and light is produced:- burning of wood, bursting of crackers. b. Chemical changes when sound is produced:- bursting of crackers, bomb explosion c. Chemical changes where colour change take place:- rusting of iron, browning of apples	3						
16	Chemical changes are very important in our lives. All new substances are formed as a result of chemical changes. For example, digestion of food in our body, ripening of fruits, fermentation of grapes, etc., happen due to series of chemical changes. A medicine is the end product of a chain of chemical reactions.	3						

17	<p>a. A change in which one or more new substances are formed is called a chemical change. A chemical change is also called a chemical reaction. Any example of chemical change.</p> <p>b. The different characteristic of chemical changes are: - *Heat, light or any other radiation (ultraviolet, for example) may be given off or absorbed.</p> <p>* Sound may be produced.</p> <p>* A change in smell may take place or a new smell may be given off.</p> <p>*A color change may take place.</p> <p>*A gas may be formed.</p>	5(2+3)
18	In test tube A which contains ordinary water rusting takes place because in it iron nail is in direct contact of air and water. The nail in test tube B becomes dull while no rusting takes place in test tube C because it does not come in contact with air but only water is there. By the above observations we conclude that both air and water are essential for rusting.	5
19	<p>a. It is a chemical change.</p> <p>b. Magnesium oxide</p> <p>c. Metal when exposed to air for a longer duration reacts with the oxygen in the air, hence forming a layer of magnesium oxide. This layer of magnesium oxide slows down or does not allow it to burn. To remove this layer magnesium ribbon is rubbed with the sandpaper and thereby helping in the desired complete burning of the ribbon.</p>	4(1+1+2)
20	<p>a. It is a chemical change.</p> <p>b. In the presence of moisture, an iron combines with atmospheric oxygen to form a brown-coloured chemical called rust (iron oxide). The process is called rusting.</p> <p>c. The brownish substance is called rust. It can be prevented by painting, galvanization, oiling etc.</p>	4(1+1+2)

CHAPTER 6: RESPIRATION IN ORGANISMS

Q.NO.	QUESTION	MARKS
SECTION A		
1.	The respiratory organs of cockroaches are _____ a. Gills b. Trachea c. Spiracles d. Both b and c	1
2.	When air is drawn in during inhalation then, a. Ribs move out b. Diaphragm moves down c. Both a) and b) d. None of the above	1
3.	After vigorous exercise the rate of respiration _____ a. Decreases b. Increases c. Remains the same d. None of these	1
4.	In anaerobic respiration, the end products are _____ a. Alcohol+ carbon dioxide + energy b. Carbon dioxide + water + energy c. Lactic acid + energy d. None of the above.	1
5.	In cellular respiration, the raw material used is _____ a. Fructose b) Sucrose c) Glucose d) Starch.	1
6.	The tiny sacs in the lungs which help in exchange of gases are called _____ a. Bronchi b. Nostrils c. Alveoli d. Trachea	1
7.	Following question consists of two statements – Assertion (A) and Reason (R). Answer these questions selecting the appropriate option given below: (a) Both A and R are true and R is the correct explanation of A. (b) Both A and R are true but R is not the correct explanation of A. (c) A is true but R is false. (d) A is false but R is true. ASSERTION: Breaking down of food happens anaerobically. REASON: It happens with inhalation of oxygen.	1
8.	ASSERTION: We must eat at regular intervals. REASON: Food provides us energy.	1
SECTION B		
9.	Define a) aerobic respiration b) anaerobic respiration	2
10.	Write the equations of	2

	A) Aerobic respiration B) Anaerobic respiration	
11.	Analyze why you get muscle cramps after heavy exercise?	2
12.	Define Breathing rate. What is the average breathing rate in humans?	2
13.	What is inhalation and exhalation?	2
SECTION C		
14	Differentiate between aerobic and anaerobic respiration.	3
15	Write a short note on how breathing takes place in different organisms. A) Fish B) Cockroach C) Earthworm.	3
16	Analyze how breathing rates differ with our activities?	3
SECTION D		
17	Explain the process of breathing in humans with a labelled diagram.	5
18	Compose an activity demonstrating the mechanism of breathing in humans.	5
SECTION E		
19	Sita likes to eat Dosa. She told her mother to prepare it one day. Her mother prepared the batter and forgot to keep it outside the freeze for 6 hours. Next day Sita was not able to eat her favorite dosa and then she had to wait for it for the next day. a. What could be the reason that the dosa batter was not ready? b. What else can be prepared using the same above microorganism. c. What are the products formed during respiration by that particular microorganism?	4
20	A group of people were smoking in a restaurant. The atmosphere was full of smoke. An old man sitting near the group asked them to stop smoking while sitting on the premises or to move out. a) Write two hazards of smoking. b) Mention names of any two places where smoking is prohibited. c) How does smoking affect the person who does not smoke?	4

ANSWER KEY (CHAPTER 6: RESPIRATION IN ORGANISMS)

Q.NO.	ANSWER	MARKS
SECTION A		
1	d)	1
2	c)	1
3	b)	1
4	a)	1
5	c)	1
6	c)	1
7	d)	1
8	a)	1

SECTION B										
9	Respiration taking place in presence of oxygen is aerobic respiration. Respiration taking place in the absence of oxygen is called anaerobic respiration.	2								
10	AEROBIC RESPIRATION- Glucose → carbon dioxide + water + energy. ANAEROBIC RESPIRATION— Glucose → alcohol + carbon dioxide + energy	2								
11	During heavy exercise as muscles do not get enough oxygen , respire anaerobically. Then, the partial breakdown of glucose produces lactic acid.so, the accumulation of lactic acid causes muscle cramps.	2								
12	The number of times a person breathes in a minute is called the breathing rate. On an average an adult human being at rest breathes in and out 15-18 times in a minute.	2								
13	The taking in of air rich in oxygen into the body is called inhalation. Giving out of air rich in carbon dioxide is known as exhalation.	2								
SECTION C										
14	<table border="1"> <thead> <tr> <th>Aerobic</th> <th>Anaerobic</th> </tr> </thead> <tbody> <tr> <td>Oxygen is required for this type of respiration to take place.</td> <td>No requirement of oxygen in this process.</td> </tr> <tr> <td>Glucose breaks down or completes oxidation into carbon dioxide and water.</td> <td>Glucose breaks down into ethyl alcohol, carbon dioxide, and energy.</td> </tr> <tr> <td>All higher organisms such as mammals perform this type of respiration.</td> <td>Lower organisms such as bacteria or other prokaryotes and yeast follow this type of respiration.</td> </tr> </tbody> </table>	Aerobic	Anaerobic	Oxygen is required for this type of respiration to take place.	No requirement of oxygen in this process.	Glucose breaks down or completes oxidation into carbon dioxide and water.	Glucose breaks down into ethyl alcohol, carbon dioxide, and energy.	All higher organisms such as mammals perform this type of respiration.	Lower organisms such as bacteria or other prokaryotes and yeast follow this type of respiration.	3
Aerobic	Anaerobic									
Oxygen is required for this type of respiration to take place.	No requirement of oxygen in this process.									
Glucose breaks down or completes oxidation into carbon dioxide and water.	Glucose breaks down into ethyl alcohol, carbon dioxide, and energy.									
All higher organisms such as mammals perform this type of respiration.	Lower organisms such as bacteria or other prokaryotes and yeast follow this type of respiration.									
15	Fish take water into their mouth, passing the gills just behind its head on each side. Dissolved oxygen is absorbed from—and carbon dioxide released to—the water, which is then dispelled. In cockroaches, respiration occurs through spiracles – a small opening on the sides of its body. When air through external openings enters into its respiratory system, spiracles serve as muscular valves paving way to the internal respiratory system. The respiratory organ of cockroaches is referred to as tracheae. In earthworms,they breathe through their skin. Air dissolves on the mucus of their skin, so they MUST stay moist to breathe. If worms dry out, they suffocate. As fresh air is taken in through the skin.	3								
16.	When you exercise and your muscles work harder, your body uses more oxygen and produces more carbon dioxide. To cope with this extra demand, your breathing has to increase from about 15 times a minute (12 liters of air) when you are resting, up to about 40–60 times a minute (100 liters of air) during exercise.	3								
SECTION D										
17	Breathing: Breathing is a physical process that involves intercostal muscles which lie between the ribs and the diaphragm and help in breathing. It involves 2 actions that are inhalation and exhalation.	5								

	<p>Mechanism of breathing:</p> <p>Inhaling:</p> <p>During inhaling, the intercostal muscles contract, the ribs are pushed upward and outward, and the diaphragm contracts and moves downward. And this upward and outward movement of the ribs and the descending movement of the diaphragm add to the space in the chest cavity. It increases the volume of the air-tight chest cavity and creates pressure inside the lungs. Air rushes from the outside through the trachea to the air sacs and alveoli.</p> <p>Exhaling:</p> <p>During exhaling, the intercostal muscles relax, and simultaneously two movements take place, that is the ribs move downward and inward, and the diaphragm relaxes and moves upward to take up its original position. This movement reduces the space in the chest cavity and the air rushes out of the lungs. The lungs get vacant and then contract.</p> <p>Appropriate well labelled diagram.</p>	
18	Any appropriate activity according to the given question.	5
SECTION E		
19	<p>a) The dosa batter was not ready as it was not fermented by yeast microorganism. It takes 5 to 6 hrs for fermentation (anaerobic respiration). During this it produces carbon dioxide gas which makes the batter rise.</p> <p>b) Any relevant answer or Bread, Biscuits, chapati etc</p> <p>c) Alcohol, carbon dioxide and energy.</p>	<p>2</p> <p>1</p> <p>1</p>
20	<p>a) Smoking causes chronic bronchitis and heart disease</p> <p>b) Cinemas and hospitals or any relevant answer</p> <p>c) People who have never smoked who live with people who do smoke are at increased risk of a range of tobacco-related diseases and other health risks, including: Heart disease and stroke.</p>	<p>1</p> <p>1</p> <p>2</p>

CHAPTER 7: TRANSPORTATION IN ANIMALS AND PLANTS

Q NO	SECTION A	MAR KS
1	Which of the following organisms do not have circulatory fluid? a. cockroach b. Hydra c. Rat d. Earthworm	1
2	The fluid part of the blood is called ____ a. RBC b. WBC c. Plasma d. platelets	1
3	The rhythmic contraction and relaxation of the heart is called as? a. pulse rate b. heart beat c. conduction d. all of the above	1
4	Which tissue conducts water and nutrients in plants? a. xylem b. phloem c. both of the above d. none of the above	1
5	Doctors feel the heartbeat with the help of an instrument called a a. Microscope b. Periscope c. Kaleidoscope d. stethoscope	1
6	What is correct sequence of transport of urine out of the body a. urethra→ureter →urinary bladder→>kidney b. Kidney→urinary bladder→ureter→urethra c. Kidney→ureter→urinary bladder→urethra d. ureter→urinary bladder→urethra→kidney	1
7	Aquatic animals like fishes excrete cellular waste as _____ which directly dissolves in water. a. Uric acid b. Ammonia c. Urea d. Nitrogen	1
8	Question no.8 consists of two statements – Assertion (A) and Reason (R). Answer these questions selecting the appropriate option given below: (a) Both A and R are true and R is the correct explanation of A. (b) Both A and R are true but R is not the correct explanation of A. (c) A is true but R is false. (d) A is false but R is true.	1

	Assertion- Arteries carry blood from the heart to all parts of the body. Reason- Arteries divide further to form veins.	
SECTION B		
9	If a person's kidney fails due to injury or infection, what will happen to the person ?	2
10	Enlist the role of root hairs in a plant body?	2
11	Justify that transpiration helps in transportation of substances in plants?	2
12	Why is there a need to excrete waste out of our body?	2
13	Amrita was playing and fell down and got her knee injured. Blood was flowing out from the wound. After a few minutes she noticed that bleeding had stopped and a dark red clot had formed on the clot. Comment upon it.	2
SECTION C		
14	Suppose Anil has developed a condition in which his body is unable to form platelets. What could be the consequences?	3
15	Compare between veins and arteries.	3
16	An artery always carries oxygen rich blood but pulmonary artery carries CO_2 rich blood yet it is called an artery. Justify it.	3
SECTION D		
17	Raman while walking accidentally stepped upon an earthworm. He noticed that there was no blood flow from its body. Don't you think earthworms don't have blood? If yes, why is it not visible? If not, how transportation occurs in earthworms?	5
18	If we peel off the bark of a shrub in our garden what will happen to the plant? State the reason for your answer.	5
SECTION E		
19	Plants take water and mineral nutrients from the soil through the roots and transport it to the leaves. The leaves prepare food for the plant, using water and carbon dioxide during photosynthesis. Food is the source of energy and every cell of an organism gets energy by the breakdown of glucose. The cells use this energy to carry out vital activities of life. Therefore food must be made available to every cell of an organism. Answer the following questions a. Which tissue is responsible for transportation in plants? b. What is the role of stomata in transportation? c. How is the food prepared by the leaves carried to the parts which cannot make food?	4
20	Priyanka with her mother once visited her relative who was admitted in a clinic. Outside the patient room it was named as the dialysis room. She was surprised to see the set up of tubes in the patient's body. After coming home she enquired her mother about that relative's condition. Based on the scenario answer the following questions; a. What is dialysis? b. Dialysis can be an alternative to which system of the body? c. Is there any other option or way apart from dialysis to save a person with kidney failure? What is that ?	4

ANSWER KEY (CHAPTER 7: TRANSPORTATION IN ANIMALS AND PLANTS)

AO	Q NO	SECTION A	MARKS								
	1	b)	1								
	2	c)	1								
	3	b)	1								
	4	a)	1								
	5	d)	1								
	6	c)	1								
	7	b)	1								
	8	c)	1								
		SECTION B									
	9	Waste products start accumulating in the blood as a result a person can't survive.	2								
	10	They absorb water and minerals from soil and increase surface area for absorption.	2								
	11	transpiration generates suction pull which can pull water to great heights in the plants.	2								
	12	When our cells perform their functions, certain waste products are released. These are toxic and hence need to be removed from the body.	2								
	13	The clot is formed because of the presence of a type of cell in the blood called platelets.	2								
		SECTION C									
	14	Excess loss of blood due to no clotting.	3								
	15	<table border="1"> <tr> <td>Veins</td> <td>Artery</td> </tr> <tr> <td>Veins carry CO₂ rich blood.</td> <td>Arteries carry O₂ rich blood.</td> </tr> <tr> <td>Valves are present in veins.</td> <td>There are no valves in arteries.</td> </tr> <tr> <td>Veins carry blood towards the heart.</td> <td>Arteries carry blood away from the heart.</td> </tr> </table>	Veins	Artery	Veins carry CO ₂ rich blood.	Arteries carry O ₂ rich blood.	Valves are present in veins.	There are no valves in arteries.	Veins carry blood towards the heart.	Arteries carry blood away from the heart.	3
Veins	Artery										
Veins carry CO ₂ rich blood.	Arteries carry O ₂ rich blood.										
Valves are present in veins.	There are no valves in arteries.										
Veins carry blood towards the heart.	Arteries carry blood away from the heart.										
	16	Pulmonary arteries carries blood away from the heart just like other arteries through blood is CO ₂ rich.	3								
		SECTION D									
	17	They do have blood but it lacks haemoglobin which imparts red color to the blood. Transport of gases is done with the help of skin.	5								
	18	Transportation of substances will be hampered. As the vascular tissues consisting of xylem and phloem are found on the bark of the plant.	5								
		SECTION E									
	19	a. Xylem and phloem or vascular tissues b. Stomata perform transpiration which creates suction pull that help in conduction of water and minerals. c. The food is transported to all parts of the plants by phloem vascular tissue.	2 1 1								
	20	a. The blood of the person with kidney failure is filtered periodically through an artificial kidney, this process is called dialysis. b. Excretory system. c. Kidney transplant.	2 1 1								

CHAPTER 8: REPRODUCTION IN PLANTS

Q NO	SECTION A	MARKS
1	A plant consists of different parts. Name the part of the plant which is not vegetative: a. Stem b. Root c. Flower d. Leave	1
2	Mention the mode of reproduction in fungi a) Fragmentation b) Budding c) Spore formation d) Vegetative propagation	1
3	The process of fusion of the male and female gametes is called: a. Fertilization b. Pollination c. Reproduction d. Seed formation	1
4	Mature ovary forms the a. Seed b. Stamen c. Fruit d. Pistil	1
5	A Student observed that a pond was covered with green coloured patches within a week. By which method of reproduction did they spread? a. Fragmentation b. Budding c. Spore formation d. Vegetative propagation	1
6	A yellow powdery substance is present in the anther of the Hibiscus flower that participates in the reproduction process. Name this substance. a. Pollen grains b. filament c. stigma d. style	1
7	Directions: - The question below consists of an Assertion (A) and a Reason(R). Use the following key to choose the appropriate answer. a. Both A and R are true and R is the correct explanation of A. b. Both A and R are true and R is not the correct explanation of A. c. A is true but R is false. d. A is false but R is true. Assertion (A): Parts of stamen are anther and filament. Reason (R): Bisexual flowers are those which contain both stamen and pistil.	1
8	Assertion (A): In asexual reproduction only, single parent is involved.	1

	Reason (R): Vegetative propagation is the method of sexual reproduction in plants.	
SECTION B		
9	A student kept a piece of bread in a moist and warm place for a few days. After few days, what will he see a. Name the organism that grows on the bread piece? b. What type of reproduction does this organism show?	2(1+1)
10	What are bisexual flowers? Write its examples also.	2
11	a. In potatoes, what type of reproduction is seen? b. Take a fresh potato. Observe the scars on it with the help of a magnifying glass. You may find bud(s) in them. What are these scars also called?	2
12	What are the advantages of vegetative propagation?	2
13	Sketch the different types of pollination.	2
SECTION C		
14	a. In which part of the flower does fertilization occur? b. Draw and label different parts of the flower	3(1+2)
15	Observe the given figure and answer the following question. a. Write the name of the plant?  b. What type of reproduction is shown? c. From where the new plants are developing?	3 (1+1+)
16	Differentiate between asexual and sexual reproduction.	3
SECTION D		
17	Define asexual reproduction. Describe different methods of asexual reproduction any three with drawing.	5 (2+3)
18	What is seed dispersal? What is the importance of seed dispersal? What are the different ways of seed dispersal?	5 (1+2+2)
SECTION E		
19	You know that the flowers are the reproductive parts of a plant. Stamens are the male reproductive part and pistil is the female reproductive part. Anther contains pollen grains which produce male gametes. A pistil consists of stigma, style and ovary. Ovary contains one or more ovules. The female gamete or the egg is formed in an ovule. In sexual reproduction a male and a female gamete fuse to form a zygote. 1. Where anther is found in the flower? 2. How will zygote be formed? 3. Explain the process of how zygote is formed?	4(1+1+2)
20	Take a piece of yeast cake or yeast powder from a bakery or a chemist shop. Take a pinch of yeast and place it in a container with some water. Add a spoonful of sugar and shake to dissolve it. Keep it in the warm part of a room. After an hour, put a drop of this liquid on a glass slide and	4(1+1+2)

observe under a microscope. You may see the formation of new yeast cells. The small bulb-like projection coming out from the yeast cell is called a bud. The bud gradually grows and gets detached from the parent cell and forms a new yeast cell. The new yeast cell grows, matures and produces more yeast cells. Sometimes, another bud arises from the bud forming a chain of buds. If this process continues, a large number of yeast cells are produced in a short time.

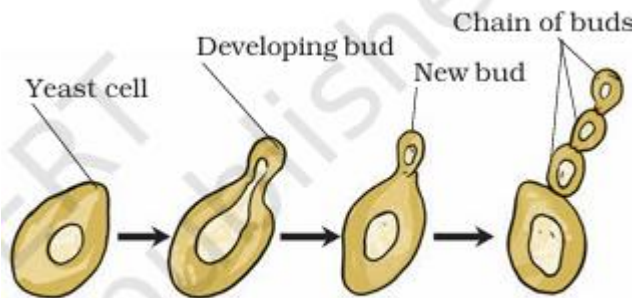
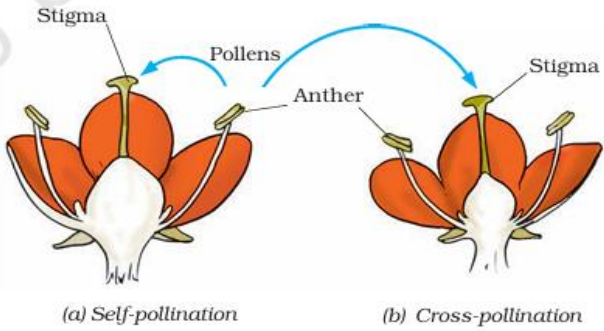
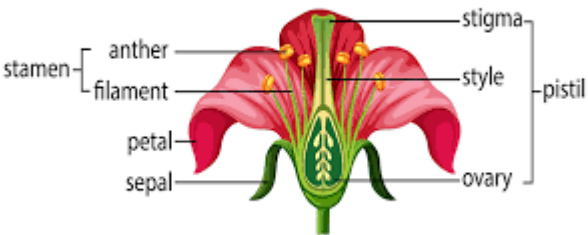

Fig. 12.5 Reproduction in yeast by budding

- What type of asexual reproduction is shown?
- Write examples of the organisms that will show the above mode of reproduction
- What would happen if instead of a warm place we kept the container in the cold place?

ANSWER KEY (CHAPTER 8: REPRODUCTION IN PLANTS)

Q.NO.	SOLUTION	MARKS
1	c) flower	1
2	c) spore formation	1
3	a)Fertilization	1
4	c)Fruit	1
5	a)Fragmentation	1
6	a)Pollen grains	1
7	b)Both A and R are true and R is not the correct explanation of A	1
8	c)A is true but R is false	1
9	a. Bread mould/fungi	2

	b. Spore formation									
10	Flowers which contain both stamens and pistils are called bisexual flowers. Mustard, rose and petunia are examples of bisexual flowers.	2								
11	a. Vegetative Propagation b. These scars are called Eyes.	2								
12	Plants produced by vegetative propagation take less time to grow and bear flowers and fruits earlier than those produced from seeds. The new plants are exact copies of the parent plant, as they are produced from a single parent.	2								
13	 <p>(a) Self-pollination (b) Cross-pollination</p> <p>Fig. 12.10 Pollination in flower</p>	2								
14	a. Fertilization occurs in ovary. b.	3(1+2)								
										
15	a. Bryophyllum b. Vegetative reproduction c. From leaves.	3(1+1+1)								
16	<table border="1" data-bbox="323 1594 1248 1751"> <thead> <tr> <th>Asexual Reproduction</th> <th>Sexual Reproduction</th> </tr> </thead> <tbody> <tr> <td>It does not involve fusion of gametes.</td> <td>It involves fusion of gametes.</td> </tr> <tr> <td>It requires only one parent.</td> <td>It requires two parents.</td> </tr> <tr> <td>No seeds are formed</td> <td>Seeds are formed.</td> </tr> </tbody> </table>	Asexual Reproduction	Sexual Reproduction	It does not involve fusion of gametes.	It involves fusion of gametes.	It requires only one parent.	It requires two parents.	No seeds are formed	Seeds are formed.	3
Asexual Reproduction	Sexual Reproduction									
It does not involve fusion of gametes.	It involves fusion of gametes.									
It requires only one parent.	It requires two parents.									
No seeds are formed	Seeds are formed.									
17	In asexual reproduction new plants are obtained without production of seeds. Vegetative propagation: - It is a type of asexual reproduction in which new plants are produced from roots, stems, leaves and buds. Since	5(2+3)								

reproduction is through the vegetative parts of the plant, it is known as

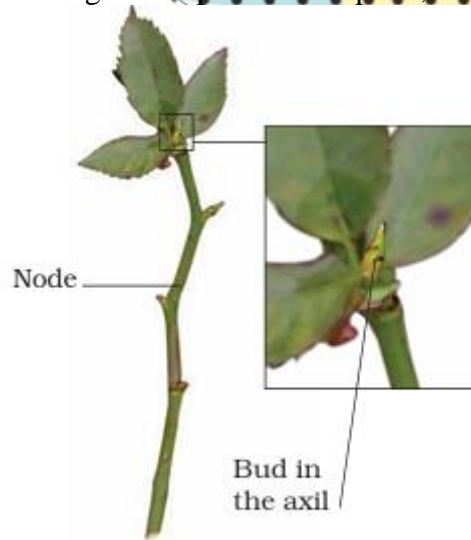

Fig. 12.1 Stem-cutting of rose

vegetative propagation.

Fragmentation:- When water and nutrients are available algae grow and multiply rapidly by fragmentation. An alga breaks up into two or more fragments. These fragments or pieces grow into new individuals. This process of reproduction is known as fragmentation.

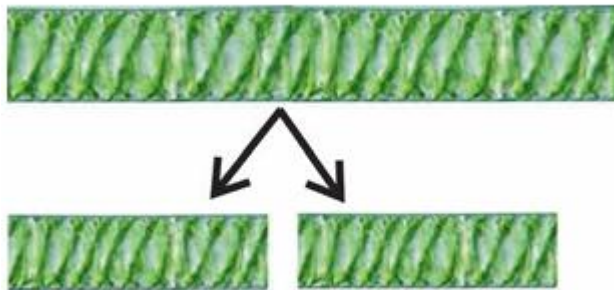

Fig. 12.6 Fragmentation in spirogyra (an alga)

Spore formation:- It is a type of asexual reproduction in which the reproductive body's spores are present in the sac-like structure called sporangium. Under favourable conditions, a spore germinates and develops into a new individual. Plants such as moss and ferns also reproduce by means of spores.

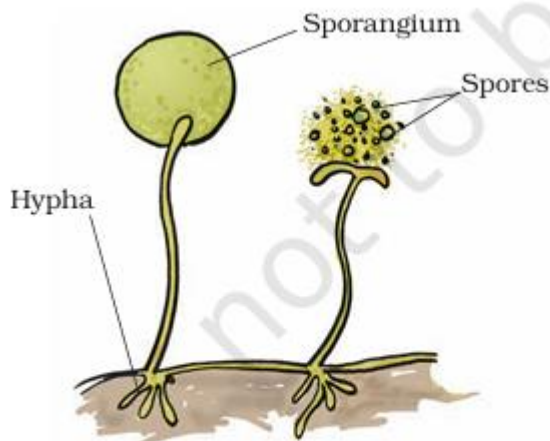



Fig. 12.7 Reproduction through spore formation in fungus

18	<p>Seed dispersal is the method by which seeds are dispersed from one place to another away from the parents. Seed dispersal helps the plants to (i) prevent overcrowding, (ii) avoid competition for sunlight, water and minerals and (iii) invade new habitats.</p> <p>Method of seed dispersal:- The various way by which seed are dispersed are:</p> <ol style="list-style-type: none"> Wind: wing-like structure helps in the dispersal of fruits and seeds over the wind. Ex:- sunflower Water: the fruits which can float on the water are dispersed through this water. Ex:- coconut Animals: fruits which are spiny or have hooks get attached to the body of grazing animals and get dispersed to far away places. Ex:- Xanthium Jerk: sometimes seeds are dispersed through the sudden jerk and burst of the fruit. Ex:- Castor Human Beings:- human beings carry fruit and disperse it away from the parent plant. Ex:- mango 	5
19	<ol style="list-style-type: none"> Anther is found in stamen. Zygote will be formed by the fusion of the gametes. Stamens are the male reproductive part and pistil is the female reproductive part. Anther contains pollen grains which produce male gametes. Ovary contains one or more ovules. The female gamete or the egg is formed in an ovule. During pollination, transfer of the pollen occurs from anther to the stigma. When the pollen grains reach the stigma a pollen tube is generated. Through this pollen tube pollen runs down through the style to the ovary. The pollen grain thus fertilize the ovary. This fusion of male and female gametes is called fertilisation. 	4(1+1+2)
20	<ol style="list-style-type: none"> Budding Hydra and yeast In the cold places, yeast will not be able to reproduce and there will be no production of the new individual. 	4(1+1+2)

CHAPTER 9: MOTION AND TIME

S NO	QUESTIONS	MARKS
SECTION A		
1.	A bus travels 54 km in 90 minutes. The speed of the bus is (a) 0.6 m/s (b) 10 m/s (c) 5.4 m/s (d) 3.6 m/s	1
2	Seema walks to her school which is at a distance of 4 km from her home in 30 minutes. On reaching she finds that the school is closed and comes back in her friend's vehicle to home in 10 minutes. Her average speed in km/h is (a) 8 km/h (b) 24 km/h (c) 20 km/h (d) 16 km/h	1
3	An example of Oscillatory motion is (a) Motion of a swing. (b) Movement of a car on a straight road (c) Motion of earth around the sun (d) Motion of a cycle wheel	1
4	The meter that measures the distance moved by a vehicle is (a) Speedometer (b) Odometer (c) Anemometer (d) Thermometer	1
5	The time taken by a pendulum of given length to complete one oscillation is (a) Different at different times (b) Same at all times (c) Increases at different times (d) Decreases at different times	1
6	A rabbit runs at a speed of 72 Km/h. Calculate its speed in m/s (a) 55m/s (b) 42m/s (c) 20m/s (d) 64m/s	1
7	Assertion (A) : The distance moved by an object in unit time is called its speed. Reason (R) : Faster vehicles have higher speeds. (a) Both A and R are true and R is the correct explanation of A. (b) Both A and R are true but R is not the correct explanation of A. (c) A is true but R is false. (d) A is false but R is true.	1
8	Assertion(A) - The distance time graph for the motion of an object moving with a constant speed is not a straight line. Reason(R) - An object moving along a straight line covers equal distance in equal intervals of time it is said to be uniform motion.	1

	(a) Both A and R are true and R is the correct explanation of A. (b) Both A and R are true but R is not the correct explanation of A. (c) A is true but R is false. (d) A is false but R is true.													
SECTION B														
9	Differentiate between a uniform and non-uniform motion.	2												
10	If a bus travels 252 km in 4 hours, estimate its speed.	2												
11	Match the given activities with the measurement of time taken <table border="1" style="margin-left: 20px;"> <thead> <tr> <th>Activity</th> <th>Time taken</th> </tr> </thead> <tbody> <tr> <td>1. Year</td> <td>a. Time to reach your school</td> </tr> <tr> <td>2. Months</td> <td>b. Rotation of earth on its own axis</td> </tr> <tr> <td>3. Day</td> <td>c. Gestation period in humans</td> </tr> <tr> <td>4. Minutes</td> <td>d. Age of a person</td> </tr> </tbody> </table>	Activity	Time taken	1. Year	a. Time to reach your school	2. Months	b. Rotation of earth on its own axis	3. Day	c. Gestation period in humans	4. Minutes	d. Age of a person			
Activity	Time taken													
1. Year	a. Time to reach your school													
2. Months	b. Rotation of earth on its own axis													
3. Day	c. Gestation period in humans													
4. Minutes	d. Age of a person													
12	Mention any two uses of Distance-Time graph	2												
13	Estimate how many minutes are there in a year.	2												
14	Categorise the following Movement of seconds hand in a watch, car moving on a straight road, movement of the wheel of a car, movement of a pendulum, movement of hand of a marching soldier, movement of a pencil while drawing a side of a square <table border="1" style="margin-left: 20px;"> <thead> <tr> <th>Straight line</th> <th>Circular</th> <th>Periodic</th> </tr> </thead> <tbody> <tr> <td> </td> <td> </td> <td> </td> </tr> <tr> <td> </td> <td> </td> <td> </td> </tr> </tbody> </table>	Straight line	Circular	Periodic							3			
Straight line	Circular	Periodic												
15	(i) Define time period (ii) If a pendulum completes 60 oscillations in 20 seconds, calculate its time period.	1 2												
16	(i) Ajay is travelling by a bus from his village to Hyderabad. He noted down the distance and time in a tabular form. Create a distance-time graph for him by plotting the values on a graph. <table border="1" style="margin-left: 20px;"> <tbody> <tr> <td>Time (hr)</td> <td>X</td> <td>2</td> <td>4</td> <td>6</td> <td>8</td> </tr> <tr> <td>Distance(Km)</td> <td>Y</td> <td>40</td> <td>80</td> <td>120</td> <td>160</td> </tr> </tbody> </table>	Time (hr)	X	2	4	6	8	Distance(Km)	Y	40	80	120	160	2 1
Time (hr)	X	2	4	6	8									
Distance(Km)	Y	40	80	120	160									

	(ii) Identify the type of motion from the graph	
17	<p>The odometer of a car reads 10745 km at 5:15pm. It travels for the next 45 min. Now odometer reads 10755 km.</p> <ol style="list-style-type: none"> 1. What is the distance travel by the car 2. Calculate the speed of the car in Km/hr 3. What is the S.I. unit of speed 	<p>2</p> <p>2</p> <p>1</p>
18	<ol style="list-style-type: none"> 1. Draw a well labelled diagram of a simple pendulum showing different positions of the bob while oscillating. 2. With the help of diagram explain <ol style="list-style-type: none"> a. One oscillation a. Time period b. Frequency 	<p>2</p> <p>3</p>
19	<ol style="list-style-type: none"> 1. Distance time graph of an object was found to be a parallel line horizontal to the time axis. Mention the state of the object. Also draw the graph. 2. Draw a bar graph showing the number of girls and boys in your class. 	<p>2</p> <p>2</p>
20	<ol style="list-style-type: none"> 1. Devise a way to form a simple pendulum on your own. <div style="display: flex; justify-content: space-around; align-items: center;">   </div> <ol style="list-style-type: none"> 2. <ol style="list-style-type: none"> a. What is the time period of the pendulum to complete one oscillation? b. What happens if the minute hand of a clock stops working? 	<p>2</p> <p>1</p> <p>1</p>

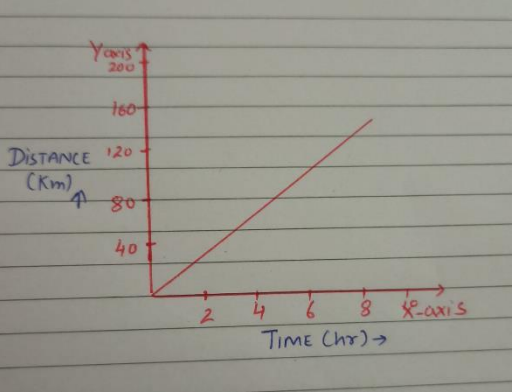

ANSWER KEY (CHAPTER 9-MOTION AND TIME)

	SOLUTION	MARKING									
1	b	1M									
2	d	1M									
3	a	1M									
4	b	1M									
5	b	1M									
6	c	1M									
7	b	1M									
8	d	1M									
9	When a body travels equal distance in an equal interval of time, then the body is said to be in a uniform motion. When a body travels an unequal distance in an equal interval of time, then the body is said to be in non-uniform motion.	1 + 1=2M									
10	Total distance travelled = 252 km Total time taken = 4 hours Speed = distance/time = 252/4 = 63 km/hr	2M									
11	1-d, 2-c, 3- b, 4- a	2M									
12	Nature of motion of a body, to calculate the speed	2M									
13	In a year, we have 365 days and 1 day = 24 h $24 \times 365 = 8760$ h $8760 \times 60 = 525600$ min	2M									
14	<table border="1" style="width: 100%; border-collapse: collapse;"> <thead> <tr> <th style="width: 33%;">Straight line</th> <th style="width: 33%;">Circular</th> <th style="width: 33%;">Periodic</th> </tr> </thead> <tbody> <tr> <td>car moving on a straight road</td> <td>Movement of seconds hand in a watch</td> <td>movement of a pendulum</td> </tr> <tr> <td>movement of a pencil while drawing a square</td> <td>movement of the wheel of a car</td> <td>movement of hand of a marching soldier</td> </tr> </tbody> </table>	Straight line	Circular	Periodic	car moving on a straight road	Movement of seconds hand in a watch	movement of a pendulum	movement of a pencil while drawing a square	movement of the wheel of a car	movement of hand of a marching soldier	1 X 3= 3M
Straight line	Circular	Periodic									
car moving on a straight road	Movement of seconds hand in a watch	movement of a pendulum									
movement of a pencil while drawing a square	movement of the wheel of a car	movement of hand of a marching soldier									
15	(i) Time period is defined as the time taken for a single oscillation. (ii) Total time taken = 20 s Number of oscillations = 60 Time period = total time taken/total number of oscillations = 20/60 = 0.33s	1M 2M									

16	 <p>(i)</p> <p>(ii) Uniform motion</p>	
17	<p>1. Distance travel by the car = final reading of odometer – initial reading of odometer = 10755-10745 = 10 Km</p> <p>0. Time taken by the car = 45 min Speed = distance / time = 10/0.75 =13.33 km/hr</p> <p>0. m/s</p>	2 2 1
18	<p>1. page no. 146 fig 13.4 (NCERT textbook, class VII)</p> <p>2. Oscillation: The pendulum is said to have one complete oscillation when its Bob starting from its mean position O moves to A to B and back to O</p> <p>that time taken by the pendulum to complete one oscillation is called time period</p> <p>Number of oscillations completed in one second or in unit time is called its frequency</p>	2 3
19	<p>1. The object is at rest. Correct graph</p> <p>2. Correct representation of the data</p>	1+1 2
20	<p>1. Any method which leads to the formation of a simple pendulum. For example, suspending a small ball with the help of thread, etc.</p> <p>2. a) 1 second</p> <p>b) The clock will not function</p>	2 1 1

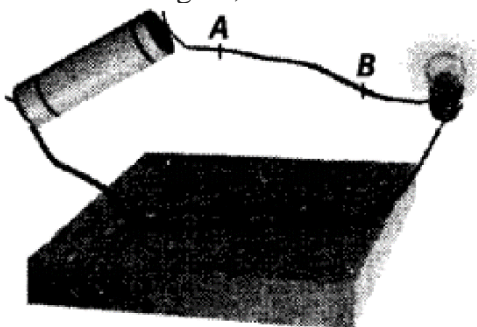
CHAPTER 10: ELECTRIC CURRENT AND ITS EFFECTS

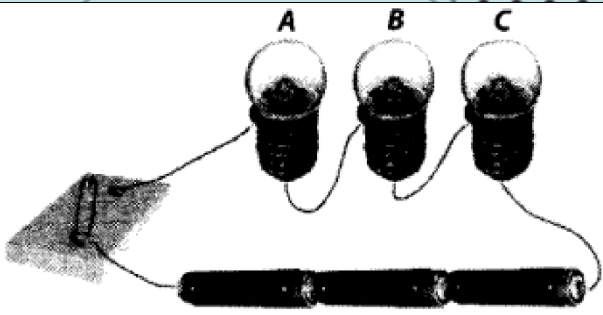
Q.No	QUESTIONS	MARKS
	SECTION-A	
1	<p>When an electric current flows through a copper wire AB as shown in figure, the wire</p>  <p>(a) deflects a magnetic needle placed near it. (b) becomes red hot. (c) gives electric shock. (d) behaves like a fuse.</p>	1
2	<p>Choose the statement which is not correct in the case of an electric fuse.</p> <p>(a) There is a maximum limit on the current which can safely flow through the electric circuits. (b) Fuses are inserted in electric circuits of all buildings (c) There is a minimum limit on the current which can safely flow in the electric circuits. (d) If a proper fuse is inserted in a circuit it will blow off if current exceeds the safe limit.</p>	1
3	<p>Which of the devices use a battery?</p> <p>(a) TV remote control (b) Transistor (c) Torch (d) All of these</p>	1
4	<p>In a bulb there is a thin wire called</p> <p>(a) fuse wire (b) coil (c) element (d) filament</p>	1
5	<p>A glowing bulb becomes warm due to the</p> <p>(a) chemical effect of current (b) magnetic effect of current (c) heating effect of current (d) physical effect of current</p>	1
6	<p>The amount of heat produced in a wire depends on its</p> <p>(a) thickness (b) length (c) material (d) all of these</p>	1
7	<p>Three bulbs A,B,C are connected in a circuit as shown in figure. When the switch is ON</p>	1

	 <p>a) bulb C will glow first b) bulb B and C will glow simultaneously and bulb A will glow after some time. c) all the bulbs A, B and C will glow at the same time (d) the bulbs will glow in the order A, B and C.</p>	
8	When the bulb gets fused, the electric current (a) flows in the circuit (b) sometimes flows and sometimes not (c) does not flow in the circuit (d) none of these	1
SECTION-B		
9	Name any two effects of electric current.	2
10	Draw the symbols for a bulb and a battery	2
11	Name two appliances in which battery is used.	2
12	Draw an closed and an open electric circuit.	2
13	What is an heating effect of an electric circuit?	2
SECTION-C		
14	Give reasons: (a) Copper and aluminium wires are usually employed for electricity transmission. (b) Explain how the resistance of a wire varies with its length. (c) The tungsten is used almost exclusively for filament of electric lamps.	3
15	Paheli made an electromagnet by winding 50 turns of wire over an iron screw. Boojho also made an electromagnet by winding 100 turns over a similar iron screw. Which electromagnet will attract more pins? Give reason.	3
16	a) Why is an electric fuse required in all electrical appliances? b) Explain how a battery can be constructed.	3 (1.5+1.5)
SECTION-D		
17	Identify the given appliance and write its name and working.	5(1+4)
		

18	Explain about the following along with the symbol. a. Cell, b. battery and c. fuse	5 (1+2+2)
SECTION-E		
19	The wire gets hot when an electric current passes through it. This is the heating effect of the electric current. Answer the following: a. Name an appliance where the heating effect of the electric current is used? b. What is an element? c. What happens when a large current passes through a wire?	4(1+1+2)
20	If a large current passes through a wire, the wire may become so hot that it may even melt and break. Compass needle gets deflected when the current flows in a nearby wire. Answer the following: a. The current carrying wire acts as a magnet. Who invented this? b. Which appliance has an electromagnet? c. What is an electromagnet?	4(1+1+2)

ANSWER KEY (CHAPTER 10: ELECTRIC CURRENT AND ITS EFFECTS)

Q NO	SECTION A	MARKS
1	(a) deflects a magnetic needle placed near it.	1
2	(c) There is a minimum limit on the current which can safely flow in the electric circuits.	1
3	(d) All of these	1
4	(d) filament	1
5	(c) heating effect of current	1
6	(d) all of these	1
7	(c) all the bulbs A, B and C will glow at the same time.	1
8	(c) does not flow in the circuit	1
SECTION B		
SECTION-B		
9	Heating effect of current and magnetic effect of electric current	2

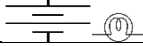
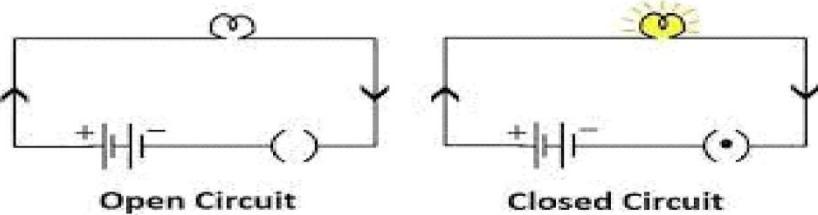

10		2
11	Torches and TV remote controls etc	2
12	<p style="text-align: center;">Open and Closed Circuit</p>  <p style="text-align: center;">Open Circuit Closed Circuit</p>	2
13	The wire gets hot when an electric current passes through it. This is the heating effect of the electric current.	2
SECTION C		
14	<p>(a) Due to the low resistance and strength of aluminium and copper, both the metals are usually employed for the transmission of electricity.</p> <p>(b) There is always an increase in the length of the wire with the increase in its resistance.</p> <p>(c) Since tungsten has high melting point and high resistance. So, that is why, the tungsten is used exclusively for filament of electric lamps.</p>	3
15	<p>Since the magnetic effect directly depends on the number of turns of the coil. As Boojho's coil has more number of turns than Paheli. So, his electromagnet is stronger than Paheli.</p> <p>So, the electromagnet of Boojho attracts more pins as compared to Paheli.</p>	3
16	<p>a. Electric fuse is required in all electrical appliances to prevent damage from excessive current flow and during short circuits.</p> <p>b. A battery is a combination of two or more cells and it can be constructed by placing cells properly on cell holder in such a way that the positive terminal of one cell is connected to the negative terminal of another with a piece of wire.</p>	3 (1.5+1.5)
SECTION D		
17	<p>The given appliance is an Electric Bell.</p> <p>It consists of a coil of wire wound on an iron piece. The coil acts as an electromagnet. An iron strip with a hammer at one end is kept close to the electromagnet. There is a contact screw near the iron strip. When the iron strip is in contact with the screw, the current flows through the coil which becomes an electromagnet. It, then, pulls the iron strip. In the process, the hammer at the end of the strip strikes the gong of the bell to produce a sound. However, when the electromagnet pulls the iron strip, it also breaks the circuit. The current through the coil stops flowing. The coil is no longer an electromagnet. It no longer attracts the iron strip. The iron strip comes back to its original position and touches the contact screw again. This completes the circuit. The current flows in the coil and the hammer strikes the gong again. This process is repeated in quick succession. The hammer strikes the gong every time the circuit is completed. This is how the bell rings.</p>	5 (1+4)

18	<p>a. In the symbol of the electric cell, the longer line represents the positive terminal and the thicker, shorter line represents the negative terminal.</p> <p>b. the positive terminal of one cell is connected to the negative terminal of the next cell. Such a combination of two or more cells is called a battery.</p> <p>c. Wires made from some special materials melt quickly and break when large electric currents are passed through them. These wires are used for making electric fuses.</p>	5 (1+2+2)
SECTION E		
19	<p>a. Electric heater</p> <p>b. An electric heater contains a coil of wire. This is called an element.</p> <p>c. When a large current passes through a wire, the wire may become so hot that it may even melt and break.</p>	4 (1+1+2)
20	<p>a. Hans Christian Oersted</p> <p>b. An electric bell</p> <p>c. When the electric current is passed through a conductor then it acts as a magnet. Such materials are called electromagnets.</p>	4(1+1+2)

CHAPTER 11: LIGHT

Q NO	SECTION A	MARKS
1	Light travels in a ... a. Curved path b. Zig-zag path c. Straight path d. None of the above	1
2	A real image can be formed by a. Plane mirror b. Concave mirror c. Convex mirror d. Both concave and convex mirror	1
3	Image formed by a plane mirror is.... a. Real b. Virtual c. Both real and virtual d. None of the above	1
4	The inner surface of a curved spoon act as a _____ mirror a. Concave b. Convex c. Plane d. None of the above	1
5	An erect and enlarged image can be formed by a. Plane mirror b. Concave mirror c. Convex mirror d. None of the above	1
6	The magnifying mirror is a. Plane b. Concave c. Convex d. None of the above	1
7	White light is composed ofcolours a. Five b. Six c. Seven d. Eight	1
8	Directions: - The question below consists of an Assertion (A) and a Reason(R). Use the following key to choose the appropriate answer. a. Both A and R are true and R is the correct explanation of A. b. Both A and R are true and R is not the correct explanation of A. c. A is true but R is false. d. A is false but R is true. Assertion (A): Virtual image is formed by diverging rays.	1

	Reason (R): Real image is formed by converging rays.	
SECTION B		
9	Megha is standing at a distance of 8m in front of the plane mirror. a) What will be the distance of the image from the mirror. b) What will be the distance of the image from Megha.	2 (1+1)
10	Name the type of lens which: a. Converge a beam of light. b. Diverge a beam of light.	2(1+1)
11	What is lateral inversion in plane mirror?	2
12	How many colours are there in sunlight? Name them.	2
13	Give an example where concave and convex mirrors are used in our daily life.	2
SECTION C		
14	Boojho visits a nearby hospital. He also visited the clinic of an ENT specialist and a dentist and requested the doctor to show him the mirrors used for examining ear, nose, throat and teeth. a. Can you recognize the kind of mirror used in these instruments? b. The doctor provided Boojho with two types of lenses and asked to identify the lenses as concave and convex without touching them. Can you do the same?	3(1+2)
15	write an activity to show that a concave mirror converges the light ray.	3
16	David is observing his image in a plane mirror. The distance between David and the mirror is 4 m. If he moves 1 m towards the mirror, what is the distance between David and his image?	3
SECTION D		
17	a. Write two uses of concave and convex lenses each. b. write the differences between concave and convex lenses(any 3).	5(2+3)
18	Observe the given picture and answer the following questions  a. Which phenomenon of light is observed here? b. Describe the phenomenon with the help of suitable examples. c. Why is the word 'AMBULANCE' written in a strange manner in an ambulance van?	5 (1+2+2)
SECTION E		

19	<p>Place a lighted candle in front of a plane mirror. Try to see the flame of the candle in the mirror. It appears as if a similar candle is placed behind the mirror.</p>  <p>a. cite two uses of this mirror in your day to day life. b. correlate it with your daily life. c. What are the properties of the image formed by a plane mirror?</p>	4(1+1+2)
20	<p>The curved shining surface of a spoon acts as a mirror. The most common example of a curved mirror is a spherical mirror.</p>  <p>a. What is a concave mirror? b. What is a convex mirror? c. Distinguish between real and virtual images?</p>	4(1+1+2)

ANSWER KEY (CHAPTER 11: LIGHT)

Q.NO.	SOLUTION	MARKS
1	c) straight line	1
2	b) concave mirror	1
3	b) virtual	1
4	a) Concave	1
5	a) Concave mirror	1
6	a) Convex mirror	1
7	c) seven	1
8	b) Both A and R are true and R is not the correct explanation of A.	1
9	a) 8m b) 16m	2
10	a) Convex lens b) Concave lens	2
11	In the mirror the 'right' appears 'left' and the 'left' appears 'right' of the image. This is known as lateral inversion.	2
12	There are seven colours in the sunlight. These are — red, orange, yellow, green, blue, indigo and violet.	2
13	Concave mirrors are used in automobiles and motor vehicles headlights, torchlights, railway engines, etc. as reflectors. Convex mirrors are used as rear-view mirrors in automobiles and vehicles	2
14	a. These instruments have concave mirrors. b. If the image is larger than the object then it is a convex lens. If the image is smaller than the object then it is a concave lens.	3(1+2)
15	Take a concave mirror. Hold it facing the Sun. Try to get the light reflected by the mirror on a sheet of paper. Adjust the distance of the paper until you get a sharp bright spot on it. Hold the mirror and the sheet of paper steady for a few minutes. This bright spot is, in fact, the image of the Sun. 	3
16	The given distance between David and the mirror is 4m. so, the distance between the mirror and the image is also 4m. When David moves 1 m towards the mirror then the distance between David and the mirror will be $4\text{m} - 1\text{m} = 3\text{m}$. The image formed behind the mirror is 3m.	3

	Therefore the distance between David and his image = $3m+3m=6m$									
17	<p>a. Convex lens can be used in a lot of things like overhead projector, camera, focus sunlight, simple telescope, projector microscope, magnifying glasses etc whereas concave lens can also be used in a lot of things like spy holes in the doors, glasses, some telescopes etc.</p> <p>b.</p> <table border="1"> <thead> <tr> <th>Convex lens</th> <th>Concave lens</th> </tr> </thead> <tbody> <tr> <td>It is thicker in the middle and thinner at the edges</td> <td>It is thinner in the middle and thicker at the edges</td> </tr> <tr> <td>It converge the light</td> <td>It diverge the light</td> </tr> <tr> <td>Image is real</td> <td>Image is virtual</td> </tr> </tbody> </table>	Convex lens	Concave lens	It is thicker in the middle and thinner at the edges	It is thinner in the middle and thicker at the edges	It converge the light	It diverge the light	Image is real	Image is virtual	5(2+3)
Convex lens	Concave lens									
It is thicker in the middle and thinner at the edges	It is thinner in the middle and thicker at the edges									
It converge the light	It diverge the light									
Image is real	Image is virtual									
18	<p>a. Lateral inversion</p> <p>b. When the image of an object is erect but is inverted in the lateral side, it is called lateral inversion. Images formed by plane mirrors are laterally inverted, i.e., the left side comes to the right and the right comes to the left.</p> <p>c. "AMBULANCE" is written in a strange manner in the ambulance van so that the drivers of the vehicles in front of the van can read correctly through their rear view mirror. This will help them to give a way to the ambulance van.</p>	5								
19	<p>a. The candle, which appears behind the mirror, is the image of the candle formed by the mirror.</p> <p>b. The candle itself is the object.</p> <p>c. The image formed by a plane mirror is erect. It is virtual and is of the same size as the object. The image is at the same distance behind the mirror as the object is in front of it.</p>	4(1+1+2)								
20	<p>a. A convex mirror is a spherical mirror with an outwardly bulged surface. Its reflecting surface is the outer side of the mirror.</p> <p>b. A concave mirror is a spherical mirror with an inwardly curved surface. Its reflection surface is the inner side of the mirror.</p> <p>c.</p> <table border="1"> <thead> <tr> <th>Real image</th> <th>Virtual image</th> </tr> </thead> <tbody> <tr> <td>Images can be seen on the screen</td> <td>Images cannot be seen on the screen</td> </tr> <tr> <td>Images are inverted</td> <td>Images are erect</td> </tr> </tbody> </table>	Real image	Virtual image	Images can be seen on the screen	Images cannot be seen on the screen	Images are inverted	Images are erect	4(1+1+2)		
Real image	Virtual image									
Images can be seen on the screen	Images cannot be seen on the screen									
Images are inverted	Images are erect									

CHAPTER 12: FORESTS-OUR LIFE LINE

Q. No.	SECTION A	MARKS
1	Humus is formed by the action of _____ on dead plants. a. Thunder b. Sea animals c. Microorganisms d. Human	1
2	Which of the following statements is not correct? a. The various components of the forest are interdependent on one another. b. We get various products from the forests. c. Forests protect the soil from erosion. d. Forests do not provide habitat to animals.	1
3	Branchy part of a tree above the stem is known as a. Crown b. Canopy c. Humus d. Understorey	1
4	Following is not the example of decomposers a. Bacteria b. Fungus c. Star fish d. microorganism	1
5	Removal of top layer of soil is called as a. soil conservation b. soil erosion c. ground water d. afforestation	1
6	Layer of dead and decaying leaves, fruits etc. on forest floor is known as a. humus b. nutrients c. producers d. decomposers	1
7	Find the correct food chain from the following a. grass → insects → frog → eagle b. grass → insect → goat → lion c. grass → goat → cow → lion d. all are correct	1
8	Plants release _____ through the process of respiration. a. O ₂ b. N ₂	1

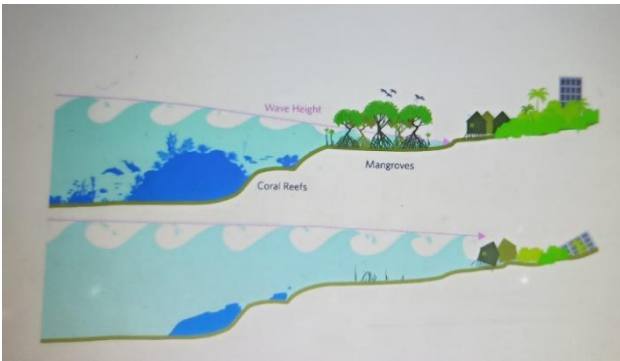
	c. CO ₂ d. H ₂	
SECTION B		
9	What kind of trees are there in top and bottom layers of an understorey?	2
10	List four products obtained from forest?	2
11	What is an understorey?	2
12	Explain how deforestation is related to increase in earth's temperature?	2
13	The forest nearby Raju's village is decreasing day by day. Can you think of two reasons for this decrease?	2
SECTION C		
14	Relate the decrease in ground water level with deforestation.	3
15	What are decomposers? What are their roles in the forest?	3
16	 <p>(Courtesy: global mangrove alliance)</p> <p>Observe the above diagram and answer the following questions</p> <ol style="list-style-type: none"> What is deforestation? Compare both the situations and analyze the importance of mangroves. 	3
SECTION D		
17	To encourage tourism in your area, the department of tourism has marked a place to build a guest house for visitors. for the construction they have proposed to cut a large portion of a forest nearby. <ol style="list-style-type: none"> Write a letter to the department of tourism explaining the importance of forests. What could be the consequences of deforestation? 	5
18	<ol style="list-style-type: none"> Why are forests called green lungs? What can we do to conserve forest? 	5
SECTION E		
19	By harbouring a greater variety of plants, the forest provides greater opportunities for food and habitat for the herbivores. Larger number of herbivores means increased availability of food for a variety of carnivores. The wide variety of animals helps the forest to regenerate and grow. Decomposers help in maintaining the supply of nutrients to the growing	4

	<p>plants in the forest. Therefore, the forest is a dynamic living entity—full of life and vitality.</p> <p>a. What are herbivores and carnivores?</p> <p>b. Draw a food chain.</p> <p>c. How regeneration of forest is achieved by a wide variety of animals?</p>	
20	<p>Once visiting a forest Ranjan realized that even after a heavy rain in the forest water did not stagnate there. He thought if it had rained so heavily in his town it would have flooded the drains and roads.</p> <p>a. Why does water stagnate in Ranjan's town?</p> <p>b. Deduce the reason for no stagnation of water in the forest.</p> <p>c. What happen to water which seeps inside the ground?</p>	4

ANSWER KEY (CHAPTER 12: FOREST: OUR LIFE LINE)

Q.NO	ANSWER	MARK
1	c	1
2	d	1
3	a	1
4	c	1
5	b	1
6	a	1
7	a	1
8	a	1
9	Tall and giant trees form top layer and shrubs and tall grasses and herbs form the bottom layers.	2
10	Wood, gum, rubber, spices, medicines,	2
11	Different horizontal layers in the forests formed by the crowns of different shapes and sizes is called an understory.	2
12	If forests disappear, the amount of carbon dioxide in air will increase, resulting in the increase in the temperature of earth.	2
13	Construction of roads, buildings, industrial development, agricultural land increase. Any two or other correct answers.	2
14	Forests act as a natural absorber of rainwater and allow it to seep into the ground. It helps maintain the water table throughout the. If there will be no forest they will not reach the underground.	3
15	The microorganisms which convert the dead plants and animals to humus are known as decomposers.	3

16	<p>a. Excessive cutting of trees in a given area is termed as deforestation.</p> <p>b. Mangroves prevent erosion and reduce the force of waves and hence prevent flooding.</p>	3
17	<p>a. Importance of forests:</p> <p>Forests provide shelter to many animals. Honey, wax, gum, wood and medicines are obtained. Absorb heat and cools the surroundings. Lower noise pollution. Prevent flooding. Any three or other correct answers.</p> <p>b. Consequences of deforestation:</p> <p>Increase in earth's temperature. Floods will occur. Lack of groundwater.</p>	5
18	<p>a. Plants release oxygen through the process of photosynthesis. The plants provide oxygen for animal respiration and also maintain the balance of oxygen and carbon dioxide in the atmosphere.</p> <p>b. Stop cutting trees in excess. Promoting plantation on a large scale. Control in population.</p>	5
19	<p>a. Animals who eat plants and plant products are called herbivores. Animals who eat other animals are called carnivores</p> <p>b. Any correct food chain</p> <p>. Regeneration of forest is done by different animals when they eat fruits of different trees and spread them across the forest, new trees are grown and thus forest is regenerated.</p>	1 1 2
20	<p>a. In Ranjan's town there is no exit of rain water nor many trees which can absorb the water to seep into the ground. Hence water stagnates.</p> <p>b. In the forest roots of the plants seep the water into lower levels of ground making no stagnation.</p> <p>c. It adds to the ground water and increases its level.</p>	2 1 1

CHAPTER 13: WASTE WATER STORY

Q NO	SECTION A	MARKS
1	Decade 2005 to 2015 proclaimed as the International decade for action on a. "Water for life" b. "Clean Ganga movement" c. "Forest Protection" d. "Child right and education"	1
2	Organic impurities found in the sewage are; .Phosphates and nitrogen i. Bacteria and nitrates ii. Urea and vegetable waste iii. Pesticides Choose the correct option a. ii and iii b. iii and iv c. i and iv d. ii and iv	1
3	Point of origin of sewage water is a. kitchen b. toilets c. factories d. all of the above	1
4	Discharge of liquid industrial waste is called _____ a. Effluent b. Sewer c. Sewerage d. Sludge	1
5	In clarified water aerobic bacteria can be grown by _____ a. Chlorination b. Aeration c. Filtration d. Sedimentation	1
6	Contaminants are _____ in sewage. a. Dissolved and suspended impurities b. Chlorine c. Ozone d. None of the above	1
7	_____ is used to disinfect water. a. UV-radiations b. Ozone c. baking soda d. none of the above	1

8	Trade waste is originated from _____ a. Kitchen b. Bathroom c. Industrial and commercial organizations d. None of the above	1
SECTION B		
9	Why are manholes located at every 50 m to 60 m in the sewerage and at the points where there is change in direction.	2
10	It is usually observed that Eucalyptus trees are planted near sewage ponds. Give reasons.	2
11	a. Name the toilets which are generally used in the area which has limited supply of water. b. What are vermi cakes? How can it be beneficial for us?	1+1
12	Open drains can cause many problems in nearby areas. Give reasons in support of your answer.	2
13	Illustrate the relationship between sanitation and diseases.	2
SECTION C		
14	One can reduce the overload on WWTP (Wastewater treatment plants) by following proper sanitation and housekeeping practices. Justify.	3
15	a. Sewage water along with harmful microorganisms also contain some nutrients. Comment b. Explain onsite sewage disposal system.	1.5+1.5
16	Government strictly prohibited open defecation. In the same light, the government of India initiated a mission in 2016. a. Name that mission. b. Why is the government against open defecation and even providing funding to make toilets in rural areas? Please discuss.	1+2
SECTION D		
17	Wastewater treatment is a stepwise process. It follows the steps such as grit and sand removal tank, aeration, sloped tank, addition of disinfectants, bar screen a. Arrange above mentioned steps in order in which occurs in wastewater treatment plants. b. How sludge is different from activated sludge. Write one use of each. c. Name any two chemicals which are used to disinfect wastewater.	5 2 2 1
18	a. Water in natural resources like river, sea is cleaned naturally. Do you agree? Please discuss. b. If river water cleans itself by using natural processes then why the condition of rivers keeps on deteriorating day by day and it's become a serious issue to deal with great concern.	3 +2
SECTION E		
19	It has been observed that waste coming out of houses, industries, offices are sometimes directly thrown into the river which affects aquatic life.	2+2

Following picture shows the Yamuna river situated in Delhi. Observe the picture and answer the following questions:

a. As an active citizen, what role do you think one can play at an individual level to solve such a situation?



(mention atleast two)

b. Critically analyze the role of the government to deal with this issue.

(Hint: legal actions, rules)

c) write any one program run by government to prevent water pollution of water.

20

Paheli visited the mountain to see her grandparents. After having a tour of the village she realized that a sewerage system cannot be possible in the mountains. She also observes that most of the people defecate in the open in the fields.

a. Help Paheli to devise strategies to deal with sewage disposal in the locality.

b. Suggest some ways by which Paheli can motivate villagers to quit open defecation.

c. Name any water born diseases.

4

ANSWER KEY (CHAPTER 13: WASTEWATER STORY)

Q. NO.	SOLUTION	MARKS DISTRIBUTION
1	a) Water for life	1
2	b)iii and iv	1
3	d) All of the above	1
4	a) Effluent	1
5	b)Aeration	1
6	a)Dissolved and suspended impurities	1
7	b)ozone	1
8	c)Industrial and commercial organization	1
9	<ul style="list-style-type: none"> • to regularly check the choking of pipelines • for frequent cleaning 	1 1
10	These trees quickly absorb surplus wastewater and release pure water vapor into the atmosphere. In addition, they add a good amount of oxygen into the atmosphere.	2
11	a) vermi –processing toilets b) When human excreta is treated by earthworms it converted into vermi cakes which can be used as manure for soil.	1 1
12	Open drains create unhygienic conditions which facilitate the growth of flies, mosquitos and other insects to breed and spread a number of diseases.	2
13	Poor sanitation practices can lead to a large number of diseases in the surroundings. Defecation in the open can lead to water and soil pollution. Both the surface and groundwater can be contaminated as untreated human excreta is health hazard and cause various water borne diseases like cholera, typhoid, polio, dysentery etc.	1 1
14	<ul style="list-style-type: none"> • One can minimize wastewater by reusing the used water in other activities. For example, water used to wash vegetables can be used to watering the plants; water used for washing clothes and utensils could be reuse for washing floors and cars etc 	3

	<ul style="list-style-type: none"> Housekeeping practices like not throwing oil, paints, solid food remains, sanitary pads etc to drain pipes helps in proper degradation process and also prevent choking of drains. By using better housekeeping practices one can reduce the amount of pollutants at their source level. 	
15	<p>a) Sewage water is a complex mixture of various types of contaminants like organic, inorganic, bacteria and nutrients. Two important nutrients present in sewage are nitrogen and phosphorus.</p> <p>b) These are the systems that collect, treat and disperse wastewater generated by homes or offices. They also serve as alternative systems for sewage disposal. For example, septic tanks, chemical toilets, composting pits</p>	1.5 1.5
16	<p>a) Swachh Bharat</p> <p>b) Open defecation can cause water pollution at surface as well as ground level which can cause various water borne diseases like dysentery, cholera, typhoid etc. Open defecation can also cause soil pollution which degrades the quality of soil and hence crop production.</p>	1 2
17	<p>a) Bar screen, grit and sand tank, sloped tank, aeration, addition of disinfectants</p> <p>b) Solid organic waste like faeces collected from the bottom of sloped tank during wastewater treatment is called sludge whereas activated sludge is collected from aeration tank and consist of 97% of water and aerobic microbes.</p> <ul style="list-style-type: none"> Sludge is used to make biogas. <p>After removing water from activated sludge, dry sludge can be used as manure</p> <p>c. Chlorine and ozone</p>	2 1 1 1
18	<p>a) Yes, river water can clean itself naturally by following similar processes used in wastewater treatment plants. Muddy water flows through the grass and small plants in the river, mud and solid particles get filtered out. Microorganisms, both aerobic and anaerobic are also found in the river which can bring chemical changes in water and hence water can be treated naturally.</p> <p>b) It is true that river water can clean it naturally but the quantity and quantity of pollutants are increasing day by day because of which natural cleaning or treatment of water cannot be sufficient enough to remove all the pollutants.</p>	3 2

19	<p>a) Reuse of waste water as far as possible, encourage others to do the same, if found any issue complaint to competent authority etc.</p> <p>b) Strict rules must be formed and implemented for the industries and others to treat the water before discharging to the river; legal action must be taken in case of misconduct, etc.</p> <p>c) Ganga action plan.</p>	<p>2</p> <p>1</p> <p>1</p>
20	<p>a) Onsite sewage disposal systems can be used such as septic tanks, composting pits as it is not feasible to form a sewerage system in mountains.</p> <p>b) She can make people aware that open defecation can lead to water and soil pollution and in turn cause various water borne diseases like typhoid, polio, cholera etc. soil pollution can cause decreased quality of soil and hence reduce crop production. She can also discuss the funds provided by the government to build toilets in rural areas.</p> <p>c) Typhoid, cholera, etc. (any another example)</p>	<p>2</p> <p>1</p> <p>1</p>

CLASS – VI COMPETENCY BASED TEST ITEMS TABLE OF CONTENTS

S.NO.	NAME OF THE CHAPTER	PAGE NO.
1	COMPONENTS OF FOOD	313
2	SORTING MATERIALS INTO GROUPS	318
3	SEPARATION OF SUBSTANCES	325
4	GETTING TO KNOW PLANTS	332
5	BODY MOVEMENTS	339
6	THE LIVING ORGANISMS AND THEIR SURROUNDING	344
7	MOTION AND MEASUREMENT OF DISTANCES	350
8	LIGHT, SHADOWS AND REFLECTIONS	356
9	ELECTRICITY AND CIRCUITS	362
10	FUN WITH MAGNETS	366
11	AIR AROUND US	371

CHAPTER 1 COMPONENTS OF FOOD

Q.No.	Questions	Marks
1	<p>Identify the group of food items which are called body building food?</p> <p>a) milk, fish, carrot, papaya b) guava, tomato, lemon, amla c) meat, fish, paneer, egg, milk d) vegetables, spinach, bottle-gourd, methi</p>	1
2	<p>Deficiency diseases can be prevented by taking</p> <p>a) balanced diet b) medicines c) vitamin C and Vitamin A d) mint and coriander</p>	1
3	<div style="text-align: center;">  </div> <p>Shikha is eating rice. She wanted to test the component of food present in rice. Which chemical she should prefer?</p> <p>a) Copper sulphate and Caustic soda b) oil c) Iodine solution d) Fehling's solution</p>	1
4	<p>It is the most essential component of our body as it controls the body temperature. The percentage of this component in our body is .</p> <p>a) 80 b) 70 c) 90 d) 45</p>	1
5	<p>Which of the following nutrients is not present in milk?</p> <p>(a) Protein (b) Vitamin D (c) Calcium (d) Vitamin C</p>	1
6	<p>Read the following statements about diseases.</p> <p>(i) They are caused by germs. (ii) They are caused due to lack of nutrients in our diet. (iii) They can be passed on to another person through contact. (iv) They can be prevented by taking a balanced diet.</p> <p>Which pair of statements best describe a deficiency disease?</p> <p>(a) (i) and (ii) (b) (ii) and (iii)</p>	1

	(c) (ii) and (iv) (d) (i) and (iii)	
7	The disease caused by deficiency of Vitamin A is a) Beriberi b) Goitre c) Anaemia d) Loss of vision	1
8	The ingredients containing some components that are needed by our body are a) Balanced diet b) Deficiency diseases c) Malnutrition d) Nutrients	1

SECTION B

9	 <p>Rahul is eating a lots of junk food like pizza, burger, pasta regularly. He is very lethargic in physical activities. Write your observation regarding the effect of his eating habits on his health? Give two suggestions to improve his food habits.</p>	2
10	Can we fulfil the nutritional requirement of our body by eating chapati or rice alone? Justify your answer giving reasons.	2
11	Sunita washes her vegetables after cutting them. Is this a right practice? Justify your answer giving reasons	2
12	(a) Write various sources of dietary fibre. (b) Why should we include them in our diet?	2
13	A student is eating pakora, after eating his dress got oily patches all over. (a) Can you identify the food component which made these oily patches? (b) Give two examples of food items containing the same nutrient.	2

SECTION C

14	(a) How many calories does a 12-year old boy or girl need each day? (b) How can the boy or girl get this in his or her diet	3
15	<p>Marasmus vs. Kwashiorkor</p>  <p>A patient has stunted growth, swelling on face, discolouration of hair and skin disease. Doctor advised him to eat a lot of pulses, grams, egg white and milk etc.</p>	3

	(a) Is this person healthy or suffering with any disease? (b) Give names of two more deficiency diseases and lack of nutrients causing it.	
16	Ravi has weak eyesight, he has difficulty in reading and writing. He went to a doctor. The doctor asked him to increase the intake of green vegetables. a) Why do you think the doctor suggested this to him ? b) Identify two other food items that can help Ravi to improve his eyesight.	3

SECTION D

17	 <p>(a) Identify the deficiency disease depicted in the picture given above. (b) Deficiency of which nutrient is responsible for the above condition? (c) Name some sources of food items which should be taken in order to prevent the above disease. (d) Generally, people living in coastal areas will not suffer from the above disease. Why? Justify giving reasons. (e) Is costly food richer in nutrients than cheap food. Comment.</p>	5
----	--	---

18	<p>Find out the sources and deficiency diseases and symptoms of deficiency of vitamin B1, Vitamin D, Vitamin C.</p> 	5
----	--	---

SECTION E

19	<p>Read the paragraph carefully and then answer these questions Our meals contain at least one item made of some kind of grain. Other items could be dal, vegetables, meat. curd, buttermilk, pickles and papad. Some examples of meals from different regions are given in table 1. Select food items you depicted on the map in chapter 2. Add some more meals to this list and enter these in the table. Sometimes we may not really have all the variety in a meal. When we travelled, we eat whatever we get food on way, not possible that time To get a variety of food items. Most of the time some reason also, why meals usually consist of such a distribution. Do you all think that our body needs different kinds of items for special purposes?</p> <table border="1" style="width: 100%; border-collapse: collapse;"> <thead> <tr> <th style="width: 20%;">Region/state</th> <th style="width: 20%;">items of grain</th> <th style="width: 20%;">items of dal</th> <th style="width: 20%;">vegetables</th> <th style="width: 20%;">other</th> </tr> </thead> <tbody> <tr> <td> </td> <td> </td> <td> </td> <td> </td> <td> </td> </tr> </tbody> </table>	Region/state	items of grain	items of dal	vegetables	other						4
Region/state	items of grain	items of dal	vegetables	other								

	Punjab	makkai ki roti	rajma	Sarson ka saag	curd, ghee	
	Maharashtra	jowar	tur dal	methi	curd	
	<p>a) Name the grain mostly common eaten by the people of Punjab? b) Name the grain commonly eaten by the people of Maharashtra? c) Write one situation when it is not possible for us to have a healthy distribution of meals.</p>					
20	<p>For growth and maintenance of good health, our diet should have all the nutrients that our body needs, in the right quantities. The diet should also contain good amounts of roughage and water. Such a diet is called a balanced diet.</p>  <p>(i) Malnutrition can lead to deficiency diseases. Evaluate the statement. (ii) Some nutrients get lost in the process of cooking and preparations. Give two examples. (iii) What is a balanced diet?</p>					4



ANSWER KEY CHAPTER 1

COMPONENTS OF FOOD

Q.No.	SECTION A	Marks
1	c) meat, fish, paneer, egg, milk	1
2	a) balanced diet	1
3	C	1
4	B	1
5	D	1
6	C	1
7	D	1
8	D	1
	SECTION B	
9	Rahul is eating food rich in fats and starch. He is not getting other essential nutrients in his diet. Due to this he may suffer from obesity and also a number of deficiency diseases. (Or any other suitable answer.) He should eat fruits and vegetables, he should eat a balanced diet.	2
10	No Chapati or rice will provide only starch which is energy giving food, therefore it cannot provide proteins, vitamins and minerals which are needed for good health.	2

11	If the vegetables and fruits are washed after cutting or peeling them, it may result in the loss of some vitamins. The skins of many vegetables and fruits contain vitamins and minerals.	2
12	(a) Dietary fibres are mainly found in vegetables, fruits, wholegrains, legumes, cucumber, carrot, lettuce. (b) To prevent constipation/for easy bowel movement we should include them in our diet.	2
13	(a)Fats, Correct answer	2
SECTION -C		
14	1800 and 2200 kcal/day Eating a balanced diet or any other correct answer	3
15	(a) This person is not healthy, he is suffering from deficiency of proteins. (b) Vitamin A – Loss of vision, Vitamin C- Scurvy (Or any two correct answers)	3
16	(a) As green vegetables will help to improve his eyesight, it is because green vegetables are a rich source of vitamin A. (b) any two	3
SECTION D		
17	(a) Goiter (b) Iodine (c) Iodized salt, fish, sea food (d) people living in coastal areas will not suffer from the above disease because they eat a lot of fish and sea food which is rich in iodine.	1+1+1+2
18	a) Sources of vitaminB1: Cereals, beans, lentils, yogurt, peas Deficiency: Beriberi Symptoms: weak muscles b) vitamin C: citric fruit deficiency: scurvy symptoms: bleeding gum c)Vitamin D: Salmon, Almond, Oily fish deficiency: Rickets symptoms: bones become soft and bend	5
SECTION -E		
19	a) Makka (maize) b) Jower c) Usually when we are traveling we have to eat whatever is available to us on the way so in such situation it is not possible to have a variety of meals or any other correct reason	4
20	(i) correct answer (ii) correct answer (iii) Balanced diet provides all the nutrients that our body needs, in right quantities, along with adequate amount of roughage and water.	4

CHAPTER 2 SORTING MATERIALS INTO GROUPS

SECTION A		1
1	 <p>An object that float in water is</p> <p>a) wood b) sugar c) Iron nail d)stone</p>	1
2.	<p>From the given options choose the one that doesn't belong to the same group.</p> <p>a) Milk b) Honey c)Iron d) Ink</p>	1.
3	<p>Wood is used as fuel; which quality make it suitable for this purpose.</p> <p>a) Combustibility b) Density c)Viscosity d)Immiscibility</p>	1
4	<p>Which pair of substance among the following would float in a tumbler half filled With water?</p> <p>a) Coconut thread, thermocoal b) Feather and plastic ball c)pin and oil drops d)rubber band</p>	1
5.	 <p>Shopkeeper usually prefers to keep the materials in</p> <p>a)Translucent container b)Opaque container c)Transparent container d)wooden rack</p>	1

6	 <p>Which of the following substances get reddish brown in colour when Exposure to air</p> <ol style="list-style-type: none"> Gold Silver Iron Aluminum 	1
7.	<p>ASSERTION AND REASON</p> <ol style="list-style-type: none"> Both A and R are true and R is the correct explanation of A Both A and R are true and R is not the correct explanation of A. A is true but R is false A is false but R is true. <p>QNO: Assertion: The materials through which objects can be seen but not clearly are known as translucent material Reason: The oily patch on paper are the translucent</p>	1
8	<p>An assertion (A) and Reason (R) are given below. Assertion(A): If we add some ammonium chloride (a solid) to a glass of water and stir it for some time, we find that solid disappears. Reason(R) Ammonium chloride is soluble in water</p>	1
SECTION B		
9	<p>A solid is put in a bucket of water, it floats just below the surface of water. What do you think, Is the Density of the object with relation to the density of water</p>	2
10	<p>Write the name of various material from which following things can be made</p> <ol style="list-style-type: none"> Bags furniture Utensils Clothes 	2

11	<p>Glass are made up of plastic, steel, paper, but can you tell why a tumbler is not made with a piece of cloth?</p> 	2										
12	<p>How do aquatic plants and animals survive in water? what do you understand . By the term solubility?</p>	2										
13	<p>Both Sneha and Mohan were asked to show soft material and hard material by providing them wood, chalk, sponge, candle, nail, stone etc. a) How they will identify? b) What do you understand by soft and hard material?</p>	2										
14	<p>During summer holidays, a group of children collected a lump of salt, green grass, Broken glass piece, ,a small thermocol box ,pen, iron nail, glass marble, hair,napThalene ball,,a piece of sugar candy, and tried to group them on the basis of properties given below help them to fill the table</p> <table border="1" data-bbox="272 981 1310 1205"> <thead> <tr> <th>Name of material</th> <th>Appearance</th> <th>Transparency/Translucent/opaque</th> <th>float/sink in water</th> <th>soluble /insoluble in water</th> </tr> </thead> <tbody> <tr> <td> </td> <td> </td> <td> </td> <td> </td> <td> </td> </tr> </tbody> </table>	Name of material	Appearance	Transparency/Translucent/opaque	float/sink in water	soluble /insoluble in water						3
Name of material	Appearance	Transparency/Translucent/opaque	float/sink in water	soluble /insoluble in water								
15	<p>With the help of experiment, How Tanisha will prove that Water is transparent Material? a) Write the meaning of Transparent. b) Examples of transparent</p>	3										
16	<p>Sunita and Manjusha are 6th class students. While coming to school, they were talking about watching a variety of things natural and artificial like water, stone, soil, books, clothes, apples, oranges etc. List any 6 properties based on which these objects can be classified?</p>	3										
17	<p style="text-align: center;">SECTION D (CASE STUDY)</p> <p>Variety of objects are given below. On basis of this, list the objects and answer the following questions A wooden Chair, Bullock cart, Cycle, shirt, Rubber ball, football, A glass marble, An apple, Orange</p> <p>QNO1) The no of Round objects in the list are a) 2 b) 3 c) 5 d) 7</p>	4										

	<p>QNO2) The no of Articles made of wood are</p> <p>a) 1 b) 2 c) 3 d) 5</p> <p>QNO3 the no of eatable articles is</p> <p>a) 1 b) 2 c) 3 d) 4</p> <p>QNO4. According to you, here on which basis, the above objects are classified,</p>	
18	<p>Students had given the following materials i.e red chillis, lemon juice, sunflower oil, Water. sugar, salt, wheat flour, mustard oil, etc.</p> <p>Make any 3 pair in such a way that one substance can be soluble in the other and other any 3 pair of substances where one substance remains insoluble in the Other substance.</p> <p>a) Soluble in water: ----- b) Insoluble in water: ----- c) Differentiate between soluble and Insoluble materials.</p>	4
19	<p>SECTION E</p> <p>Long answers</p>  <p>a) Make the differences between Transparent, Translucent and Opaque object in regard to what happens when light strike on their surface. b) Give two examples of each</p>	5 (3+2))
20	Some of the substances related to day to day life are listed below:	5



1
1
1
2

Fruits, leaves, key, paper, Steel spoon, oil, salt, straw, sawdust.
Different substances show different properties such as few floats on water, few sinks. Some are miscible whereas some are immiscible. Some are transparent, some are translucent, opaque etc.

QNO:1: Select the examples of floating material.

QNO:2 Which among them are examples of sinking object.

QNO3. Show the examples of immiscible liquid



QNO4: what do you understand by metallic lustre. Explain with the help of example.

ANSWER KEY CHAPTER – 2 SORTING MATERIALS INTO GROUPS.

1	a) wood	1
2.	c)Iron	1.
3	a) Combustibility	1
4	b) Feather and plastic ball	1
5.	c)Transparent container	1
6	c) Iron	1
7.	ASSERTION AND REASON b) Both A and R are true and R is not the correct reason of A	1
8	. Both A and R are true and R is the correct explanation.	1
	SECTION B	
9	The density of the solid and water is same, because solid neither sink not float.	2
10.	Write the name of various material from which following things can be made a) Bags: Cloth, leather, Jute and plastic b) furniture: Wood, plastic, Metal, Jute	2



	c) Utensils: Plastic, steel, Copper, Metals D) cloth: cotton, jute, polyester																																					
11	We all know that use of tumbler is to keep liquid materials. 1) Cloth piece has very minute pores through which the liquid oozes out and secondly cloth piece is not hard enough to hold liquid.	2																																				
12.	The aquatic plants and animals use oxygen dissolved in water. The property of substance due to which it dissolves in water is called solubility.	2																																				
13	a) Sneha and Mohan will identify the given materials by pressing them.,. Some of them may be hard to compress, while others can be easily compressed. a) Materials which can be compressed or scratched easily are called soft materials. Materials which cannot be compressed easily are called hard materials.	2																																				
14.	<table border="1"> <thead> <tr> <th>Name of material</th> <th>Transparency/Translucent/opaque</th> <th>float/sink in water</th> <th>soluble /insoluble in water</th> </tr> </thead> <tbody> <tr> <td>Glass piece</td> <td>Transparent</td> <td>Sink</td> <td>Insoluble</td> </tr> <tr> <td>Thermocoal</td> <td>Opaque</td> <td>float</td> <td>Insoluble</td> </tr> <tr> <td>Pen</td> <td>Opaque</td> <td>sink</td> <td>Insoluble</td> </tr> <tr> <td>Grass</td> <td>Opaque</td> <td>Float</td> <td>Insoluble</td> </tr> <tr> <td>Ironnail</td> <td>Opaque</td> <td>Sink</td> <td>InSoluble</td> </tr> <tr> <td>Glassmarble</td> <td>Translucent</td> <td>Sink</td> <td>Insoluble</td> </tr> <tr> <td>Napthalene Boll</td> <td>Opaque</td> <td>Sink</td> <td>insoluble</td> </tr> <tr> <td>Sugarcane candy</td> <td>opaque</td> <td>Sink</td> <td>soluble</td> </tr> </tbody> </table>	Name of material	Transparency/Translucent/opaque	float/sink in water	soluble /insoluble in water	Glass piece	Transparent	Sink	Insoluble	Thermocoal	Opaque	float	Insoluble	Pen	Opaque	sink	Insoluble	Grass	Opaque	Float	Insoluble	Ironnail	Opaque	Sink	InSoluble	Glassmarble	Translucent	Sink	Insoluble	Napthalene Boll	Opaque	Sink	insoluble	Sugarcane candy	opaque	Sink	soluble	3
Name of material	Transparency/Translucent/opaque	float/sink in water	soluble /insoluble in water																																			
Glass piece	Transparent	Sink	Insoluble																																			
Thermocoal	Opaque	float	Insoluble																																			
Pen	Opaque	sink	Insoluble																																			
Grass	Opaque	Float	Insoluble																																			
Ironnail	Opaque	Sink	InSoluble																																			
Glassmarble	Translucent	Sink	Insoluble																																			
Napthalene Boll	Opaque	Sink	insoluble																																			
Sugarcane candy	opaque	Sink	soluble																																			
15	Take a beaker and fill half of it with water. Place the beaker without disturbance and where light is present. Put a coin in it. Observe the coin from the top. If you see the coin clearly , it is confirming that water is transparent or any other correct proof Transparent: Materials which allow light to pass through them clearly. Ex: water. Air, Glass.	3																																				
16	The objects are identified or classified by observing size, shape, colour, hardness, solubility in water, Attraction toward magnet, conduction of heat, Transparency.	3																																				
17	a) C -5 b) B- 2 c) B – 2	4																																				

	d) We know that materials differ in some of their properties and they may also be similar in some of their property's materials can be grouped on the basis of similarities or differences in their properties.	
18	<p>a) Soluble in water: sugar in water Salt in water Lemon juice in water : Sunflower oil in Musturd oil</p> <p>b) Insoluble in water: Red chilli in water : Wheat flour in water.</p> <p>c) Soluble materials-Those materials which are dissolved in water: Ex: salt, sugar Insoluble materials: which are not dissolved in water. ex: oil. Flour</p>	4
19	<p>SECTION E</p> <p>c) Any three correct differences d) Any two correct examples</p>	5 (3+2)
20	<p>1) Floating materials: Leaves, papers, straw, sawdust</p> <p>2) Sinking materials: fruits, keys, steel spoon</p> <p>3) Oil</p> <p>4) Shining property of metals is called metallic luster. For example, steel spoon.</p>	1 1 1 2

Q No.	Questions	Marks
Section A		
1	 <p data-bbox="288 775 1262 887">Mahesh added two spoons of solid salt in a beaker containing water. On stirring the whole salt has disappeared and only liquid is seen in the beaker. The liquid in beaker is</p> <ul style="list-style-type: none"><li data-bbox="288 913 395 943">a. solute<li data-bbox="288 976 424 1005">b. solvent<li data-bbox="288 1039 395 1068">c. water<li data-bbox="288 1102 432 1131">d. solution.	1
2	<p data-bbox="288 1160 1142 1189">Which one of the method is used to get salt from the salt solution?</p> <ul style="list-style-type: none"><li data-bbox="288 1223 432 1252">a. filtration<li data-bbox="288 1285 501 1314">b. condensation<li data-bbox="288 1348 480 1377">c. evaporation<li data-bbox="288 1411 480 1440">d. winnowing	1
3	 <p data-bbox="288 1854 1015 1883">Filtration is the process to separate the components of a</p> <ul style="list-style-type: none"><li data-bbox="288 1917 523 1946">a. pure substances<li data-bbox="288 1980 424 2009">b. solution	1

	<p>c. a liquid</p> <p>d . liquid and insoluble substance</p>	
4	 <p>Observe the method and select the correct one.</p> <p>a. husk from wheat</p> <p>b. wheat and sand</p> <p>c. stalk from wheat.</p> <p>d None of these.</p>	1
5	<p>Which property is taken into consideration for separating solid mixture by sieving</p> <p>a. difference in colour</p> <p>b. difference in weight.</p> <p>c. difference in shape</p> <p>d. difference in size.</p>	1
6	<p>Setting of heavier particles present in water is called -----</p> <p>a. condensation</p> <p>b. evaporation</p> <p>c. decantation</p> <p>d. sedimentation.</p>	1
7	<p>In oceans Water is converted into water vapour, name the process involved in it.</p> <p>a. Filtration</p> <p>b. evaporation</p> <p>c. condensation</p> <p>d. sedimentation.</p>	1
8	<p>QNo. 8 is the Assertion (A) and Reasoning question. You have to select one appropriate option which is given below</p>	1

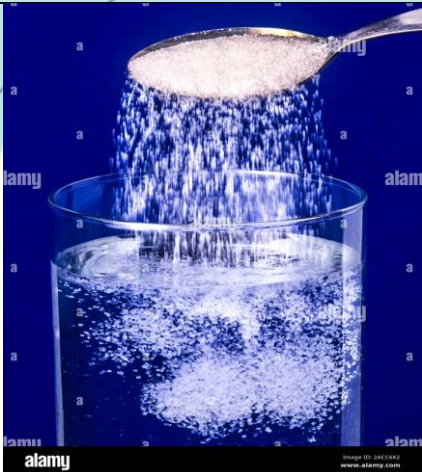
	<p>(a) Assertion and reason both are correct statements and reason is the correct explanation for assertion.</p> <p>(b) Assertion and reason both are correct statements and reason is not correct explanation for assertion.</p> <p>(c) Assertion is a true statement but reason is False statement.</p> <p>(d) Assertion is False statement but reason is True statement.</p> <p>Assertion (A)- separation of stones from rice is one of the separation methods.</p> <p>Reason- (R) the above separation method is a handpicking method of separation.</p>	
	SECTION B	
9	<p>Observe the given picture and identify the method of separation and explain this method.</p> 	2
10	<p>Identify the methods of separation from the clues given below:</p> <p>(a) Separating wheat flour from bran</p> <p>(b) Separating tea leaves from tea</p> <p>(c) Separating cream from milk</p> <p>(d) Separating sand from water.</p>	2
11	Name any two material which are used as filters in our daily life	2

12	 <p>https://images.app.goo.gl/QJ7XMaUUBc34Dq9M7</p> <p>Tara was dissolving sugar in 100 ml of water. She dissolved one spoon, then she added a second spoon of sugar , she stirred the solution and sugar was dissolved. She added a third spoon also. But she could not dissolve the fourth spoon of sugar. Why?</p>	2
13	<p>Arjun was sitting at home because it was raining. Suddenly it stopped raining after some time and he observed that everything around him appeared to be clearer and he could see his surroundings more clearly.</p> <p>Why? Justify your answer by giving reason.</p>	2
SECTION C		
14	<p>Name the property of the components used for separating the following mixtures:</p> <p>a. salt and camphor</p> <p>b. iron filings and saw –dust</p> <p>c. coconut oil and water</p>	3
15	 <p>https://images.app.goo.gl/T1JxoieoqmqqT8eWA</p>	



	Two processes are taking place in the above picture. What are they? Distinguish between these two processes	
16	Aditya has accidentally mixed oil and water. Help him to separate this mixture.	3
SECTION D		
17	Read the passage given carefully and answer the following questions Raju asked a glass of water to his friend Ankit. Ankit gave him a glass of ice-cold water. Raju observed some water droplets on the outer surface of the glass and asked Ankit (a) How are these droplets of water formed? (b) Whether energy is released or absorbed in this process? (c) Define the process involved in the above situation.	1+1+2
18	Sheela, Saima and Ravi want to dissolve more sugar in the same quantity of milk, so as to win in this game. Ravi took hot milk, while Saima took ice cold milk. But Sheela took milk at room temperature. (a) Who was able to dissolve more sugar in the same quantity of milk in the above case? (b) Who dissolved the least amount of sugar. (c) What is the reason for this?	1+1+2
SECTION E		
19	(a) Ajay has accidentally mixed chalk powder into salt. Help him to separate this mixture. (b) Reeta is making dal. How she can remove the small piece of stone, before cooking, suggests one method.	5
20	(a) Describe the method used to obtain pure salt from rock salt. (b) What do you understand about sieving. Name two important places where it is used.	5



Section A		
Q NO	Answer	Marks
1	d	1
2	c	1
3	d	1
4	c	1
5	d	1
6	d	1
7	b	1
8	a	1
SECTION B		
9	handpicking method, When undesirable materials are in less quantity compare to desirable materials	2
10	(a) Separating wheat flour from bran - sieving (b) Separating tea leaves from tea- filtration (c) Separating cream from milk- churning (d) Separating sand from water- sedimentation decantation	1/2x4 =2
11	Filter paper, cotton cloth	1+1
12	She could dissolve the first three spoons of sugar because the solution was unsaturated. (A solution that contains less than maximum amount of solute that is capable of being dissolved) After the third spoon the solution becomes saturated and that is a solution in which no more solute can be dissolved.	1+1
13	The rain drops load the dust particles with water and become heavier And quickly settle down on the ground	2
SECTION C		
14	a. sublimation b. magnetic separation c. separating funnel	1+1+1

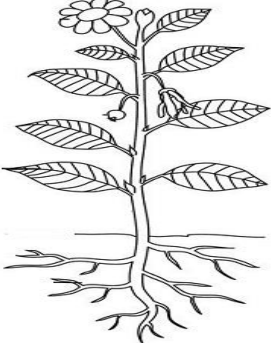

15	The two processes are Evaporation and condensation. Change of liquid into vapour by absorbing heat energy is called evaporation Conversion of vapour into liquid by cooling is called condensation.	1 2
16	Separating funnel is used to separate two immiscible liquids that are oil and water. Oil is lighter than water, it will form a layer on the top and water near the bottom of the funnel and may be drawn off/Decantation after keeping the mixture undisturbed for some time	3
SECTION D		
17	(a)Ravi was able to dissolve more sugar. (b) Saima could dissolve least amount of sugar (b)heat energy increases solubility. with the correct explanation.	1+1+2
18	(a)Water droplets are formed due to condensation, when the air comes in contact with some cold surface, water vapor present in it condenses on the cold surface in the form of droplets. (b)In this process energy is released (c) The process of conversion of vapour into liquids on cooling is called condensation.	1+1+2
SECTION E		
19	(a)The mixture of common salt and chalk powder is mixed in water. Common salt is dissolved in water whereas chalk powder is not soluble. The insoluble chalk powder is separated by the method filtration using filter paper.NaCl by evaporation. (b) Correct answer (3+2)	5
20	(a)The process of obtaining pure salt from rock salt is called crystallization. In this process, impure salt is dissolved in hot water. heating impurities does not dissolve. Hot concentrated solution is prepared and filtered to remove impurities. on cooling this solution, crystals of common salt are obtained (b) correct answer. (2+3)	5

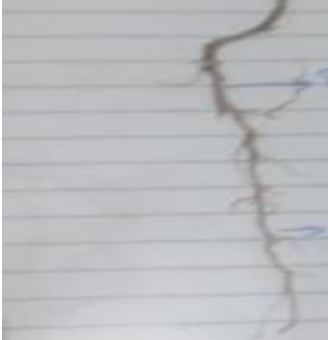

CLASS: VI

TOPIC: GETTING TO KNOW PLANTS

Q NO	SECTION A	MARKS
1	The arrangement of leaves at a node is (a) Stamen (b) Inter node (c)Phyllotaxy (d) Petal	1
2	 <p>Identify the main part of the plant which is responsible for photosynthesis?</p> <p>a. Roots b. Stem c. Leaves d. Flowers</p>	1
3	What is the primary purpose of the flowers in a plant? (a)To produce oxygen (b) To store nutrients (c) To attract pollinators for reproduction. (d) To provide support to the plant.	1
4	 <p>Identify the type of venation in a given picture.</p> <p>(a)Parallel venation (b) reticulate venation (c) both of them (d) none of the above</p>	1
5	Select from the following terms which constitute the male part of the flower? (a) sepals, petal and stamen (b) stigma, style and ovary (c) pollen grains, anther and filament	1

	(d) ovary, style and stamen	
6	<p>What is the name of the tiny openings on the surface of leaves that allow for the exchange of gases like oxygen and carbon dioxide?</p> <p>(a) pore (b) Roots (c) Stomata (d) Tubers</p>	1
7	 <p>Identify the picture and choose the correct option</p> <p>(a) Fibrous root (b) taproot (c) petiole (d) stem</p>	1
8	<p>Following question consists of two statements – Assertion (A) and Reason (R). Answer these questions selecting the appropriate option given below:</p> <p>(a) Both A and R are true and R is the correct explanation of A. (b) Both A and R are true but R is not the correct explanation of A. (c) A is true but R is false. (d) A is false but R is true.</p> <p>Assertion (A): Plant with fibrous root is having parallel venation. Reason(R): Parallel venation sometimes found with tap root.</p>	1
SECTION B		
9	<p>“I am very weak. I can’t stand alone. I need support to stand erect.” This statement is given by some plants. Can you identify the type of the plants? Give two examples.</p>	2
10	 <p>Identify the male and female parts of the flower. Draw labelled diagram of male reproductive part.</p>	2

11	 <p>Explain the purpose of the blade of the leaf. How does the shape of the blade contribute to the plant's survival?</p>	2
12	 <p>Observe the activity shown in the figure. Correlate it with the functions of the stem.</p>	2
13	<p>Draw a neat diagram of a flower and add labels for the following parts:</p> <p>a. a. The part that receives the pollen grains. b. b. The swollen base of the pistil.</p>	2
SECTION C		
14	<p>Compare and contrast the functions of sepals and petals. Why do you think both are necessary for a flower?</p>	3
15	<p>Three similar potted plants were taken to conduct an activity to determine the conditions essential for plant growth: Plant P was kept in sunlight but not watered. Plant Q was kept in sunlight and watered. Plant R was watered and kept in a dark room. (a) Which plant will grow best, and which plant(s) will not show proper growth? (b) From the above experiment list two main factors necessary for plant growth.</p>	3

	(c)Leaves were taken from each of the plants and boiled in alcohol to remove the pigment. On performing iodine tests on the leaves, what observation will be made for leaves collected from P and Q.	
16	“If we lose the bees, we lose the food. “Explain why we need to save bees for plants to survive?	3
SECTION D		
17	(a)Why are veins important for leaves? (b)Discuss the role of the petiole in a leaf. Why do you think leaves have different types of petioles? (c) Draw a neat and labelled diagram of dicot leaf.	5
18	 <p>a. Identify the phenomena demonstrated in the experiment. How it is helpful to the plant. b. What changes will be there in your observation during a hot sunny day. Why?</p>	5
SECTION E		
19	Plants are classified into 3 types: herbs, shrubs and trees  <p>Write two characteristics of shrubs. (b)Identify the set of herbs. (a)Mint, Coriander, Methi (b)Mint, Coriander, Neem (c) Neem, Alovera, basil (d)Ginger, Mango, Methi (c)Differentiate between Herbs and trees? (two points)</p>	4

20	<p>Title: "The Garden Adventure"</p> <p>Once upon a time, there was a magical garden where various plants thrived and grew happily. In this garden lived four friends – Tall Taproot, Friendly Fibrous, Parallel Pete, and Reticulate Rachel.</p> <p>Tall Taproot Carrie was a tall and slender carrot. One day, she noticed a sudden drought in the garden. Being a taproot, she extended her long root deep into the soil to reach the water table and saved herself from drying out. The other plants admired Carrie's ability to access water during tough times.</p> <p>Friendly Fibrous (Fred the Grass): Fred was a friendly clump of grass with many tiny roots spreading out in all directions. When there was heavy rain, Fred's fibrous roots prevent soil erosion by holding the soil together. The other plants appreciated Fred's role in keeping the garden soil intact.</p> <p>(a) Mention any other function of Tall Taproot, which is not mentioned in the above paragraph. (b) What type of venation will be shown by Fred the Grass? (c) Write two differences between tall Taproot and Friendly Fibrous.</p>	4
----	---	---

ANSWER KEY CH 6

GETTING TO KNOW PLANTS

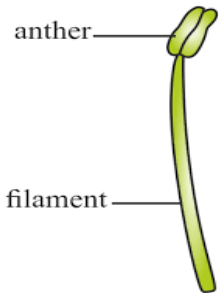
Q NO	SECTION A	MARKS
1	c	1
2	c	1
3	c	1
4	b	1
5	c	1
6	c	1
7	b	1
8	c	1
	SECTION B	
9	Climbers, Example Money plant, Grapes (1+1/2+1/2) M	2
10	Male-Stamen, Female-Pistil <div style="text-align: center;">  <p>The diagram shows a stamen with a long, thin filament at the base and a two-lobed anther at the top. Labels 'anther' and 'filament' are connected to their respective parts by thin lines.</p> </div> <p style="text-align: center;">(1/2+1/2+1) M</p>	2
11.	The flat leaf blade also protects the stomata from the sun and the shape of the leaf also directs the flow of water to keep the surface of the leaf free to	2

	absorb more light. The leaves on the stem are also arranged in such a way that they do not overlap and allows or maximum exposure to the sun. (1+1)	
12	The main function of a stem in plants is that it helps in the conduction of water and minerals from the roots to the leaves and other parts of plants. It also provides support to branches, leaves, flowers, fruits, and buds of plants. (1+1) M	2
13	a) Stigma labelled in correct position (1) b) Ovary labelled in correct position (1)M	2
SECTION C		
14	Sepals: These are leaf-like structures enclosing the bud of the flower Can be seen at the lower part of the flower It protects and folds over the closed buds from the external surrounding Usually, a flower has 2-5 sepals Sepals are collectively called calyx – the outermost whorls of flowers Petals: These are modified leaves surrounding the reproductive structures of flowers These are unusually shaped or brightly coloured attracting pollinators Collectively, all the petals are called the corolla Often, petals comprise two sections – the broader upper part resembling the leaf blade (blade) and the narrow lower part like the leaf petiole (claw) (1+1+1) M	3
15	Ans (a) Container Q, Plant P and R (b) Sunlight, Water (c) P-No change because of the absence of starch. Q- iodine solution turns bluish black in colour because of presence of starch. (1/2 x6) M	3
16	Ans Bees visit flowers to drink the nectar. As they do so the pollen grains stick to their body When they visit another plant the pollen grains get transferred and pollination takes place. The process results in the formation of fruits and seeds that give rise to new plants. If bee number drops, few insects are available to pollinate flowers. (1+1+1)	3
SECTION D		
17	(a) Veins provide support for the leaf and transport both water and minerals (via xylem) and food energy (via phloem) through the leaf and onto the rest of the plant. (b) Function: Petiole helps to twist the leaf to face the sun. It allows the transport of the energy synthesized in the leaf to the rest of the plant. It also enables the transport of nutrients and water to the leaf. (c)	5

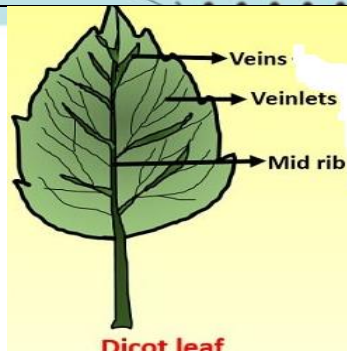



(1+2+2) M



18	<p>(a) Transpiration is the process of water movement through a plant and its evaporation from aerial parts, such as leaves, stems and flowers. It is a passive process that requires no energy expense by the plant. Transpiration also cools plants, changes osmotic pressure of cells, and enables mass flow of mineral nutrients.</p> <p>(b) Light intensity - higher light intensity levels will generally result in greater transpiration rates. This is because plants open their stomata in response to light, allowing water vapour to escape from the leaves. (3+2) M</p>	5
----	---	---



SECTION E

19	<p>(a) A plant that is small to medium in size is known as a shrub. They are woody plants that lack a thick hard trunk and differentiated branches. They have large, broad leaves.</p> <p>(b) Mint, Coriander, Methi</p> <p>(c) A herb is a non-woody plant that has an inexperienced and smooth stem with few branches on it. A tree is a woody plant that has many branches on a stem. (1+1+2) M</p>	4
----	--	---

20	<p>(a) Storage of food.</p> <p>(b) Parallel Venation.</p> <p>(c) Taproot consists of the one, long main root, where secondary, tertiary and rootlets are visible. Even the primary root is very thick as compared to other roots (Carrot, Radish). Whereas fibrous or adventitious roots contains short-lived roots, which are shallow and the growth can be either underground or aerial. (1+1+2) M</p>	4
----	--	---

No.	Questions	Marks
SECTION A		
1	<div style="text-align: center;">  </div> <p>Observe the figure and find out the correct statement.</p> <ol style="list-style-type: none"> It forms the framework of body It gives shape and structure to the body. It helps in the movement of the body. All of these 	1
2	<p>Which one of the following is an immovable joint?</p> <ol style="list-style-type: none"> ball and socket joint elbow joint upper jaw none of these. 	1
3	<p>Which important organ is protected inside the bones of the skull</p> <ol style="list-style-type: none"> heart lungs kidneys brain. 	1
4	<div style="text-align: center;">  </div> <p>Observe the figure and identify the bone Which are movable</p> <ol style="list-style-type: none"> upper jaw eye socket hinge joint lower jaw 	1

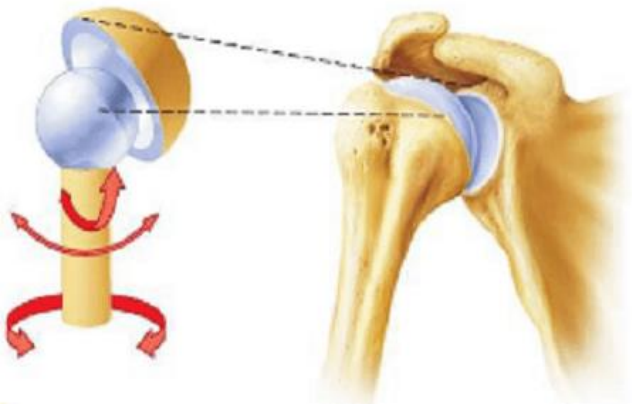
5	 <p>Observe the figure and find the number of pairs of bones in the rib cage?</p> <p>a. 10 b. 11 c. 12 d. None of these.</p>	1
6	<p>Which of the following animals moves with just one disc-shaped muscular foot?</p> <p>a. Earthworm b. tortoise c. cockroach d. snail</p>	1
7	<p>Choose the correct statement when we straighten our arm?</p> <p>a. Both biceps and triceps contract. b. Both biceps and triceps relax c. Biceps contracts but triceps relaxes d. Triceps contracts but biceps relax</p>	1
8	<p>Question consists of two statements- Assertion(A) and Reason(R). Answer these questions selecting the appropriate option given below;</p> <p>a) Both A and R are true, and R is the correct explanation of A. b) Both A and R are true, and R is not the correct explanation of A. c) A is true but R is false. d) A is false R is true.</p> <p>Assertion (A)- The ball and socket joint allow movement in all directions. Reason (R) – This joint is found in the shoulder end hip and it consists of a bone with a rounded end that fits into a cup like cavity of another bone.</p>	1
SECTION B		
9	<p>Rekha is doing exercise, she found that bone and cartilage have different characteristics. Help her to differentiate between bones and cartilage. Give one example for each.</p>	2
10	<p>Identify the type of movements exhibited by the following animals.</p> 	2
11	<p>Distinguish between ligament and tendon</p>	2

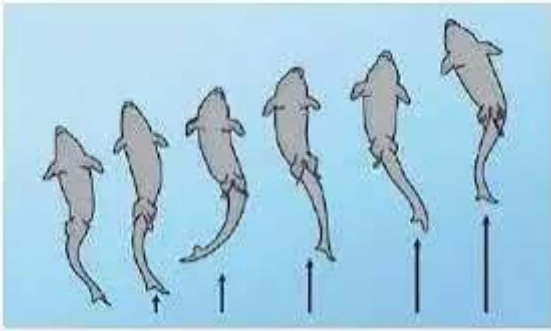
12	 <p>Identify the type of joint. Mention the type of movement possible because of this joint.</p>	2
13	What would have happened if our backbone had been made of one single bone?	2
SECTION C		
14	While riding bicycle, Amit met with an accident and got severe pain on his leg with swelling. Doctor suggested him to undergo some imaging test to understand the condition of his bone. Identify the imaging test suggested by the doctor. What is the purpose of this test. What first aid you will give, if your friend is facing such a situation.	3
15	List the characteristics features of the bird which help it to fly in the sky Name any two birds that cannot fly.	3
16	 <p>Explain the type of locomotion shown by the organism in the given image</p>	3
SECTION-D		
17	Comment on the mode of locomotion in following animals. a. Cockroach b. Earthworm	5
18	 <p>Describe the mechanism involved in the swimming of fish.</p>	5
19	Read the passage and answer the questions given below. Hinge joints are those joints that allow movement in one plane only. They do bending and straightening work such as flexing fingers. Hinge joints are	



	covered by protective covering that covers the bones and thick gel known as, synovial fluid is present between joints and they work as lubricants and allow movement of joints smoothly. These types of joints contain muscles, ligaments and other types of tissue that stabilize the joint and their movements. (a) Identify the type of joint present in the neck and elbow. (b) what type of movement is possible through the hinge joint. (c) What is the difference between a pivotal joint and hinge joint?	1+1 2
20	Read the passage and answer the questions given below The skeletal system mainly provides a structural framework and supports the body. It is made up of many bones. It comprises bones, cartilage, ligaments and tendons. The human skeletal system provides support. a. How many bones are present in an adult human? b. What is the function of the hip bone? c. Explain two important roles of the skeleton.	1+1 2



ANSWER KEY Class-6

Chapter- Body Movement

SECTION A		
Q No.	Answer	Marks
1	d	1
2	c	1
3	d	1
4	d	1
5	c	1
6	d	1
7	d	1
8	a	1
SECTION B		
9	Bones are hard and rigid, they cannot be bent, give the shape to the body, chest bone, back bone Cartilage- not hard, elastic in nature, can be bent, ear, nose	2
10	flying, swimming, creeping, flying and walking.	2
11	Ligament joins bone to bone, tendon joins bones to muscle	2
12	ball and socket joint and it move all direction	2
13	We would not bend or twist easily, the back bone is made up of small bones called vertebrae or any other correct points.	2
SECTION C		

14	By X-ray we can get photograph of a bone, Doctors use these photographs for examining fractures and dislocation of the bone. Will restrict the movement of injured part.	3
15	Birds have streamlined bodies with hollow bones, and forelimbs are modified into wings. Ostrich, Kiwi, penguin	3
16	Snake- the snake's curves into many loops. Each loop of the snake gives it a forward push by pressing against the ground.	3
SECTION D		
17	Earthworm- The earthworm moves by the extension and contraction of body muscles. The tiny bristles under the body helps in gripping the ground. cockroach-They have different muscles, which are present near the legs to help in walking. These body muscles also help in moving wings when cockroaches fly.	5
18	Body is streamlined. They use tail fins for small jerks through water and other fin assist swimming. The tail fin is also used for changing directions.	5
SECTION E		
19	i) pivotal joint, hinge joint ii) only one direction iii)allow rotational movements, only one direction	1+1 2
20	(a) 206 (b) multiaxial ball and socket joint allow movement all direction (c)i) its supporting framework of the body, it give the body shape	1+1 2

Q NO	SECTION A	MARKS
1	 <p>Neha comes across a plant having a thick fleshy stem, no leaves but spines on it. What is the habitat of the plant?</p> <p>(a) Mountain (b) Desert (c) Grassland (d) River</p>	1
2	<p>When a bright light suddenly falls on our eyes, we shut the eyes. This shows which characteristics of the living organisms?</p> <p>(a) Growth (b) Nutrition (c) Response to stimulus (d) Reproduction</p>	1
3	 <p>Identify the breathing organ</p> <p>(a) Nostrils (b) Gills (c) Skin (d) Spiracles</p>	1
4	<p>The set that represents only the abiotic components of a habitat from among the following is.</p> <p>(a) Tiger, rabbit, Grass, Soil (b) Sunlight, Soil, water, Air (c) Sand, fishes, butterfly, Rocks (d) Aquatic plant, Fish, Frog, Insect</p>	1
5	<p>Which of these events is not associated with Reproduction in organisms?</p> <p>(a) An egg hatching into a chick (b) A seed germinating into a seedling (c) A cat giving birth to a kitten</p>	1

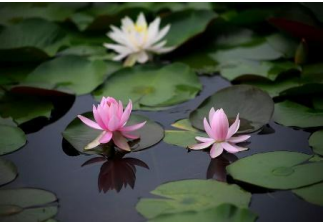
	(d) A bud blooming to form a flower	
6	Find the odd one out: (a) Yak (b) Snow leopard (c) Mountain goat (d) Lion	1
7	Question No. 7 and 8 consist of two statements – Assertion (A) and Reason (R). Answer these questions selecting the appropriate option given below: a) Both A and R are true, and R is the correct explanation of A. b) Both A and R are true, and R is not the correct explanation of A. c) A is true but R is false. d) A is false but R is true Assertion(A): Dolphins breath through the nostrils Reason(R): Dolphins are aquatic animals which do not have gills.	1
8	Assertion(A): The stems of aquatic plants are long, hollow and light. Reason(R): Long hollow stems are heavy and make the plant sink in water.	1
SECTION B		
9	Categorise these organisms into the following habitat Desert, Mountain, grassland, Aquatic <div style="display: flex; justify-content: space-around; align-items: center;"> <div style="text-align: center;">  (a) </div> <div style="text-align: center;">  (b) </div> </div> <p>(Images from NCERT textbook, class vi)</p> <div style="text-align: center;"> <p>(c)</p>  <p>https://images.app.goo.gl/aF5VGHLNjrdaKqyZ6</p> </div> <div style="text-align: center;"> <p>(d)</p>  <p>https://images.app.goo.gl/sKXiK5n7VVGaHt3T8</p> </div>	2
10	Features of certain animals are given below. Assign a habitat based on the features (a) Strong hooves for running up the rocky slopes (b) They have thick skin or fur to protect them from cold.	2

	(c) These animals have gills to help them use oxygen dissolved in water. (d) They have light brown colour to help them hide in dry grass when they hunt for prey.	
11	Which adaptive features of the camel, helps it to survive in a desert? (Any four points)	2
12	Justify how absence of leaves and presence of spines and a green fleshy stem helps a cactus plant to survive in the desert.	2
13	(a) Write an adaptation in mountain plants due to which rainwater and snow can slide off easily from the tree. (b) Write an adaptation in aquatic plants due to which the leaves and flowers can float on surface of water	2
SECTION C		
14	(a) What is meant by a habitat? (b) Which are the two main types of habitats? Differentiate between their features giving examples.	3
15	(a) There are desert animals like rats and snakes, which do not have the long legs that a camel has. How do they protect themselves from the heat of the sand? (b) How does a snow leopard protect itself from the cold of the mountains?	3
16	Mimosa, commonly known as 'touch-me-not', leaves close or fold when someone touches them. Why? Give two examples of the similar phenomenon.	3
SECTION D		
17	A lion is in the vicinity of a deer. (a) Which features of the lion will help it to catch the deer? Justify your answer by giving reasons. (b) Which features of the deer can help it to escape from the lion? Justify your answer by giving reasons.	5
18	Identify the characteristics from the given clues (a) The neck of the giraffe has elongated over a long time to eat the leaves on the high branches (b) A gum like sticky substance is given out of a plant (c) A seedling becomes a sapling and then becomes a tree (d) A parrot eating fruit on a tree (e) The stomach of a dog sleeping on the road side shows up and down movement	5
SECTION E		
19	Read the given paragraph and answer the questions that follow Some animals, like the apple snail, can survive in different ecosystems- from swamps, ditches and ponds to lakes and rivers. It has a lung/gills combination that reflects its adaptation to habitats with oxygen poor water. This is often the case in swamps and shallow waters. In the harsh cold climate of Alaska, the animals have learnt to adapt to the weather by storing food in their body and protecting themselves from the cold with thick furs. Human inhabitants in Alaska have also learnt to cope with the environment by building shelters that insulate and hold the heat, and yet do not allow the structure to melt. (a) Which adaptation of the apple snail helps it to survive in its habitat? (b) How do the animals of Alaska protect themselves in extreme cold?	4

(c) How do humans live in hot climates cope with the extreme climatic conditions? Give two examples.

20

4

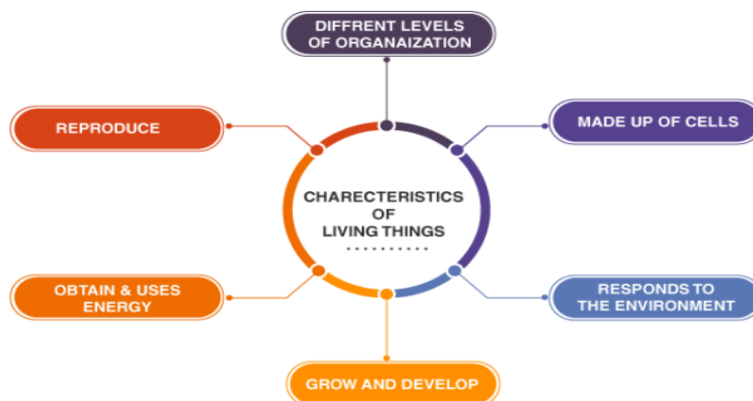

All living things have a body of some kind. Some things have body parts that allow them to walk or fly or swim. These are things like legs and wings and fins. All of the living creatures we know have to eat food in order to have the energy to move and to grow. All living things can respond to their surroundings, just like you can taste something awful then spit it out and shout “YUCK!” And all life comes from other life – just like how you came from your mother and father. So even though we look so different from other living things, we are much more the same than different.

(a) “Some things have body parts that allow them to walk or fly or swim.” Identify the characteristics of living things that are reflected in this sentence.

(b) ‘You can taste something awful then spit it out and shout “YUCK!”’ Identify the characteristics of the living organism reflected here.

(a) List four characteristics of living organisms.





ANSWER KEY CH 6 THE LIVING ORGANISMS -CHARACTERISTICS AND HABITATS

Q NO	SECTION A	MARKS
1	(b) Desert	1
2	(c) Response to stimulus	1
3	(b) Gills	1
4	(b) Sunlight, Soil, water, Air	1
5	(d) A bud blooming to form a flower	1
6	(d) Lion	1
7	(a) Both A and R are true, and R is the correct explanation of A.	1
8	c) A is true but R is false.	1
	SECTION B	
9	(a) Grassland, (b) Mountain, (c) Desert (d) Aquatic	½ *4=2
10	(a) Mountain Region (b) Mountain Region	½ *4=2

	(c) Aquatic habitat (Oceans/ Sea/ Rivers) (d) Grasslands	
11	(i) Camels have long legs which help to keep their bodies away from the heat of the sand. (ii) They excrete small amount of urine (iii) Their dung is dry and (iv) They do not sweat. Since camels lose very little water from their bodies, they can live for many days without water.	$\frac{1}{2} * 4 = 2$
12	(i) Desert plants lose very little water through transpiration. The leaves in desert plants are either absent, very small, or they are in the form of spines. This helps in reducing loss of water from the leaves through transpiration. (ii) Photosynthesis in these plants is usually carried out by the stems which are green and contain chlorophyll.	1+1
13	(a) These trees are normally cone shaped and have sloping branches. The leaves of some of these trees are needle-like. This helps the rainwater and snow to slide off easily. (b) The stems of these plants are long, hollow and light.	1+1
SECTION C		
14	(a) Habitat is the place where organisms live. The habitat provides food, water, air, shelter and other needs to organisms. (b) The two main types of habitats are terrestrial habitats and aquatic habitats. The plants and animals that live on land are said to live in terrestrial habitats. Some examples of terrestrial habitats are forests, grasslands, deserts, coastal and mountain regions. On the other hand, the habitats of plants and animals that live in water are called aquatic habitats. Lakes, rivers and oceans are some examples of aquatic habitats.	1+2
15	(a) There are desert animals like rats and snakes, which do not have the long legs that a camel has. To stay away from the intense heat during the day, they stay in burrows deep in the sand. These animals come out only during the night, when it is cooler. (b) Snow leopard has thick fur on its body including feet and toes. This protects its feet from the cold when it walks on the snow.	$1\frac{1}{2} + 1$ $\frac{1}{2}$
16	(i) Mimosa, commonly known as 'touch-me-not', leaves close or fold when someone touches them. They are responding to the stimulus of our touch. (ii) Wild animals run away when bright light is flashed towards them. Cockroaches begin to move to their hiding places if the light in the kitchen is switched on at night.	1+2
SECTION D		
17	A lion is in the vicinity of a deer. (a) Lions have long claws in their front legs that can be withdrawn inside the toes. These help the lion to kill the prey swiftly. Its light brown colour helps it to hide in dry grasslands when it hunts for prey. The eyes in front of the face allow it to have a correct idea about the location of its prey.	$2\frac{1}{2} + 2$ $\frac{1}{2}$

	(b) It has long ears to hear movements of predators. The eyes on the side of its head allow it to look in all directions for danger. The long legs and speed of the deer helps them to run away from the predators	
18	(a) The neck of the giraffe has elongated over a long time to eat the leaves on the high branches- Adaptation (b) A gum like sticky substance is given out of a plant- Excretion (c) A seedling becomes a sapling and then becomes a tree-Growth (d) A parrot eating fruit on a tree- Nutrition (e) The stomach of a dog sleeping on the road side shows up and down movement- Breathing (Part of respiration)	1+1+1 +1+1
SECTION E		
19	(a) It has a lung/gills combination which helps it to adapt to habitats with oxygen poor water. (b) They have thick furs to protect themselves from extreme cold. (c) They make houses out of bricks or mud. They paint their houses white from outside. (Or any two suitable points the student has given)	1+1+2
20	(a) Movement (b) Response to stimulus (c) Nutrition, Growth, Respiration, Excretion, Reproduction, Response to stimulus, Movement, Death (Any four)	1+1+2

Q NO	QUESTIONS	MARKS
SECTION-A		
1.	Which one is the oldest means of transport? a. Bullock cart b. Bus c. Car d. All of above	1
2.	The length covered in one step by a person is called.... a. Cubit b. Pace c. Hand span d. Finger	1
3.	What is the SI unit of length? a. Kilometre b. Meter c. Millimetres d. Centimetres	1
4.	10 Km are equal to a. 1000m b. 100m c. 10000m d. 10m	1
5.	What do we use to measure curved lengths? a. Thread b. Paper c. Sand d. Wood	1
6.	The distance between Jaipur and Delhi is usually expressed in units of a. Kilometre b. Centimetre c. Meter d. Decametre	1
7.	Sprinter in a 100m race moves along a straight track, this type of motion is called..... a. Circular b. Rectilinear c. Periodic d. Elliptical	1
8.	Question No. 8 consists of two statements – Assertion (A) and Reason (R). Answer these questions selecting the appropriate option given below: a) Both A and R are true, and R is the correct explanation of A.	1

	<p>b) Both A and R are true, and R is not the correct explanation of A. c) A is true but R is false. d) A is false but R is true. Assertion (A): - The objects which move along a straight line are said to have rectilinear motion. Reason (R): - The objects which move in a circular path are said to have circular motion.</p>	
SECTION-B		
9.	If you are sitting in a moving car, are you at rest or in motion? Explain?	2
10.	Give two examples of linear motion?	2
11.	<p>Give the unit for measuring the following.</p> <p>a. Thickness of coin</p>  <p>b. length of your eraser</p> 	2
12.	<p>Name the device used to measure the following.</p> <p>a. Your height</p>  <p>b. cloth for curtain.</p> 	2
13.	The height of a girl is 1.60 m. Express it into cm and mm.	2
SECTION-C		
14.	<p>What type of motion do the following objects exhibit?</p> <p>a. The sewing machines needle b. The blades of an electric fan c. Running along straight line</p>	3
15.	Anu's house is 4520 metres away from her school. Converts this distance to km and cm.	3
16.	How can we measure a curved line? Draw a suitable diagram.	3

SECTION-D

17. a. State two precautions to be observed while measuring length with the help of a metre scale. 5(2+3)

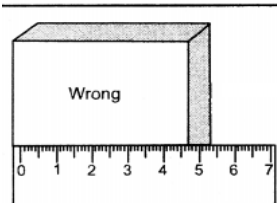

b. Which type of motion is shown the following picture. Give two examples.



18. a. Which type of motion is shown in the following picture. Give two more examples. (pendulum of clock) 5(3+2)





b. While measuring the length of a knitting needle, the reading of the scale at one end is 5.0 cm and at the other end 35.2 cm. What is the correct length of the needle?

SECTION E

19. Read the following passages to answer the questions.
 Measure the height of your classmate using a hand span and then by using a metre scale. For this, ask your classmate to stand with his back against a wall. Make a mark on the wall exactly above his head. Now, measure the distance from the floor to this mark on the wall with your hand span and then with a metre scale. 4
(1+1+2)

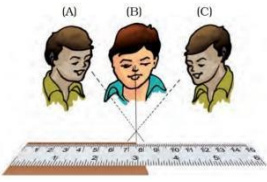
a. What is the full form of the SI unit?
 b. Why can hand span and arm length cannot be taken as standard units of length?

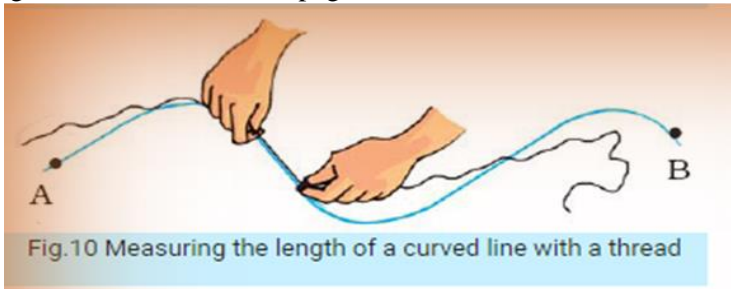

	<p>c. Between A, B and C which one is the correct method of measuring correct length. Why?</p> 	
<p>20.</p>	<p>Read the following passages to answer the questions. Observe a tailor working on a sewing machine. The sewing machine remains at the same location while its wheel moves with a circular motion. It also has a needle that moves up and down continuously, as long as the wheel rotates.</p> <p>a. The up and down motion of needle of the sewing machine can be classified as which type of motion.</p> <p>b. This picture is an example of which type of motion?</p>  <p>c. What kind of motion does a screw that is turned undergo? And differentiate it from the above motion.</p> 	<p>4 (1+1+2)</p>

ANSWER KEY CLASS-VI TOPIC- MOTION AND MEASUREMENT OF DISTANCES

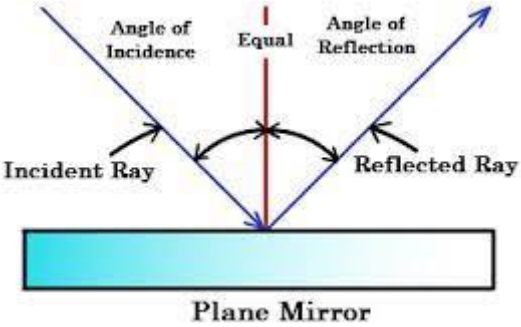

AO	Q NO	ANSWER	MARKS
		SECTION-A	
	1.	A) bullock cart	1
	2.	B) pace	1
	3.	B) metre	1
	4.	C) 10000 metres	1
	5.	A) Thread	1
	6.	A) Kilometre	1
	7.	B) Rectilinear	1
	8.	B) Both A and r are true	1
		SECTION-B	
	9.	With respect to a person sitting inside the car you are at rest because your position with respect to him is not changing. But, with respect to a person outside the car you are in motion because the respective positions are changing.	2
	10.	March past of soldiers in a parade. Motion of a vehicle on a straight road.	2
	11.	a. Millimetre b. Centimetre	2
	12.	a. Measuring tape b. Metre scale or measuring tape	2
	13.	H=1.60m 1m=100cm =1.60 x 100 cm = 160cm 1m = 1000mm = 1.60 x 1000= 1600mm Height of a girl in cm is 160 cm and in mm is 1600 mm.	2
		SECTION-C	
	14.	a. Periodic motion b. Circular motion c. Rectilinear motion	3
	15.	4520m = 4520/1000=4.520 km (1km=1000m) 4520m= 4520 x 100= 452000 cm (1m=100cm)	3
	16.	We can measure the length of a curved line by using a thread. Measure the length between the beginning and final mark on the thread. Diagram NCERT text book page no –  80	3
		SECTION-D	
	17.	a) Two precautions are:	5(2+3)

	<p>(i) The initial point of distance must coincide with the zero reading of the metre scale.</p> <p>(ii) The eye should be kept in line with the point of measurement.</p> <p>b) The motion in a straight line is called rectilinear motion. For example, motion of a bullet fired from a gun and motion of a stone falling down from a height.</p>	
18.	<p>a) The motion which repeats itself after regular intervals of time, is called periodic motion. The two examples are</p> <p>(i) revolution of moon around the earth and</p> <p>(ii) revolution of earth around the sun.</p> <p>b) Length of needle= final reading – initial reading $= 35.2 - 5.0$ $= 30.2 \text{ cm}$</p>	5(3+2)
19.	<p>a) International system of unit.</p> <p>b) Because handspan and arm length vary from person to person.</p> <p>c) Between A, B, and C, B is the correctly measuring the length because the eye of B is kept in straight line with the point of measurement.</p>	4(1+1+2)
20.	<p>a) Periodic motion</p> <p>b) Periodic motion</p> <p>c) Circular motion. Above motion is periodic motion and it is different from the circular motion. In periodic motion the object repeats its motion at regular intervals whereas in circular motion objects move in a circular path.</p>	4(1+1+2)

Q NO	SECTION A	MARKS
1	When light falls on an opaque object----- falls on the wall. (a) reflection (b) shadow (c) refraction (d) image	1
2	What is the term for a flat reflecting surface that produces virtual same sized images? (a) Convex mirror (b) Concave mirror (c) Plane mirror (d) Spherical mirror	1
3	Which statement is true about shadows? (a) Shadows are formed by transparent objects. (b) Shadows are always smaller than the objects casting them. (c) Shadows are formed when light passes through any object. (d) Shadows are formed on the side opposite to the light source.	1
4	Identify the main characteristics of a transparent object? (a) it reflects light (b) it allows light to pass through. (c) it absorbs light (d) it casts a shadow.	1
5	Neeta observed the shadow of a tree at 8:30 a.m., 12:00 noon and 2:40 p.m. Which of the following statements is near to her observation about the shape and size of the shadow of the tree she observed?  https://creativecommons.org/licenses/by-nc-sa/2.0/ (a) The size of the shadow remains the same but the shape of the shadow of the tree changes. (b) Neither the shape nor the size of the shadow changes. (c) The size and shape of the shadow of the tree changes at different intervals of time. (d) The size of the shadow of the tree changes, but the shape remains the same.	1

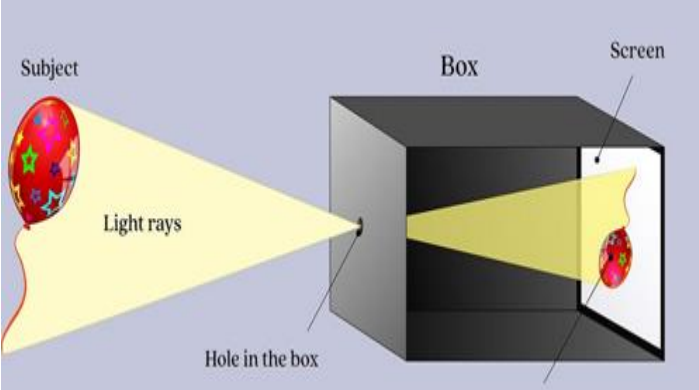
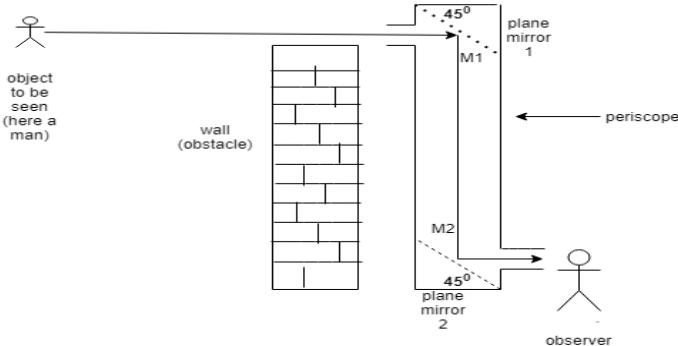
6	 <p>https://support.google.com/legal/answer/3463239?hl=en observe the picture and enlighten the property of light.</p> <ol style="list-style-type: none"> Light travel in curved line Light travel in a Zig zag Light travel in a straight line Light travel randomly 	1
7	 <p>If the angle between the incident ray and normal is double how will the angle between the reflected ray and normal be affected?</p> <ol style="list-style-type: none"> Doubled Halved Tripled Unchanged 	1
8	<p>Following question consists of two statements – Assertion (A) and Reason (R). Answer these questions selecting the appropriate option given below:</p> <ol style="list-style-type: none"> Both A and R are true and R is the correct explanation of A. Both A and R are true but R is not the correct explanation of A. A is true but R is false. A is false but R is true. <p>Assertion(A): Mirror is a transparent object. Reason(R): Transparent objects allow light to pass through them .</p>	1
SECTION B		
9	 <p>Read the word and write the mirror image of the given word. Write the phenomena involved in it.</p>	2
10	Suggest two ways to convert a transparent glass sheet into opaque without damaging it.	2

11	The air around us is always transparent. Give two observations to support this statement.	2								
12	Match the following items given in Column A with that in Column B	2								
	<table border="1"> <tr> <td>(a)Luminous body</td> <td>(a)Scattering back of the light by shining surface</td> </tr> <tr> <td>(b)Image</td> <td>(b) Does not produces light of its own</td> </tr> <tr> <td>(c)Reflection</td> <td>(c)Formed due to reflection by mirrors</td> </tr> <tr> <td>(d)Non Luminous body</td> <td>(d) Produces light of its own</td> </tr> </table>	(a)Luminous body	(a)Scattering back of the light by shining surface	(b)Image	(b) Does not produces light of its own	(c)Reflection	(c)Formed due to reflection by mirrors	(d)Non Luminous body	(d) Produces light of its own	
(a)Luminous body	(a)Scattering back of the light by shining surface									
(b)Image	(b) Does not produces light of its own									
(c)Reflection	(c)Formed due to reflection by mirrors									
(d)Non Luminous body	(d) Produces light of its own									
13	 <p>https://support.google.com/legal/answer/3463239?hl=en</p> <p>Using a pinhole camera, a student observes the image of the balloon. Comment on the characteristics of the image formed.</p>	2								
SECTION C										
14	(a)Write three letters which are similar to their mirror image. (b) Rahul is able to see his image on the newly polished marble floor. Will he be able to see the same on the wall? Why?	3								
15	Sheena is using the side view mirror of her car to do makeup. Will she be able to do it correctly? Explain the differences between plane mirrors and curved mirrors.	3								
16	List the materials which are needed for the formation of shadow in a dark room.	3								
SECTION D										
17	 <p>(a) Whether the observer is able to see through the wall. why? (b) Can we use cardboard instead of a plane mirror in this device? Give a reason. (c) Identify the device and mention its two possible uses in daily life</p>	5								
18	Two friends are playing in a park in Delhi when suddenly, dense smoky fog surrounds them, and they lose sight of each other.	5								

	<p>(a) What makes the air smoky and foggy? (b) Suggest any two methods to avoid the smoky fog. (c) What precautions should children take when playing outside in foggy conditions?</p>	
	SECTION E	
19	<p>Transparent Translucent Opaque</p>  <p style="text-align: center;">A B C</p> <p>Seema wants to set up her new house. Please help her to find the solution of the following problems.</p> <p>a. To maintain privacy in her room, which type of object she should select for the curtain.</p> <p>b. To focus her show piece in her living room so everyone can see her and appreciate it.</p> <p>c. Write two points of difference between transparent and opaque, with the help of one example of each.</p>	4
20	 <p>https://support.google.com/legal/answer/3463239?hl=en</p> <p>It was a bright sunny day. Ram was returning back from his school. He was tired. He sat under a tree covered with a very large number of leaves. There were tiny gaps between the leaves that light could pass through. He saw bright circular patches of light on the ground under the tree. Suddenly, there was a loud noise of an airplane in the sky and rushed to see the airplane. He was surprised to see that there was no shadow of the airplane on the ground. But he had studied that when there is sun and an opaque object, shadow is formed on the screen.</p> <p>a. What are the bright patches on the ground seen by Ram? b. Why could Ram not find any shadow of the airplane on the ground?</p>	4

c. In what ways are images formed by such holes differ from shadows?



ANSWER KEY



CH 8 LIGHT SHADOW AND REFLECTION

Q No	Answers	MARKS
SECTION A		
1	b	1
2	c	1
3	d	1
4	b	1
5	c	1
6	c	1
7	a	1
8	d	1
SECTION B		
9	Ans Ambulance, left appears right and right appears left or lateral inversion.	1+1
10	Ans 1 By applying paint. 2 By keeping thick obstacles. (any other)	1+1
11	Ans the air around us is usually transparent. This is the reason we can see the buildings and trees around us. When the air gets polluted, and smoke and dust particles get mixed with the air, the transparency of air decreases as the pollutant particles absorb light. (any correct point)	1+1
12	Ans a-d, b-c, c-a d-b	1/2x4
13	Ans: Pinhole camera doesn't change the colour of the image. Although the image of the balloon will be inverted when seen through the pinhole camera.	1+1
SECTION C		
14	(a)O, I, U (b)No, light does not reflect on the wall.	1.5+.5+1
15	Ans No, Plane mirror - The image formed by a plane mirror is always upright, virtual and the same size as the object no matter where the object is placed in front of the mirror. Concave mirror – The image formed by a concave mirror is inverted, real and diminished if the object is at a distance more than the focus and convex mirror a small sized erect image (any correct point)	1+1+1
16	Ans: Materials needed for shadow formation are: 1. Source of light 2. Screen 3. An opaque object obstructing the path of light	1+1+1
SECTION D		

17	<p>Ans</p> <p>(a)No, Wall is Opaque (0.5+0.5M)</p> <p>(b)No (no mark)</p> <p>Cardboard is not a polished and shiny surface. So, it reflects only a small amount of light. 2M</p> <p>(c)Periscope is used in submarine Used by soldiers in trenches to see enemies (any correct point) 2M</p>	5
18	<p>(a)Chemicals that come from sources of burning fossil fuels, such as factories or car exhaust. When particles in the air combine with ozone, they create smog. Smog is a type of air pollution that looks like smoky fog and makes it difficult to see.</p> <p>(b) Pollution check of the vehicles, to avoid unburnt carbon particles.</p> <p>(c) Always wear the proper gear, such as supportive footwear, a helmet designed for the sport you're playing, and protective eyewear if necessary. Learn the rules of the game, and don't push yourself to play above your skill level. Play on a well-kept court or field, and check for hazards before starting. (1+2+2)</p>	5
SECTION E		
19	<p>a. Opaque objects</p> <p>b. Transparent objects</p> <p>c. Those object through which light can pass easily are called transparent objects e.g. water, glass. The object which do not allow the light to pass through are called opaque object e.g. wood, stone (1+1+2)</p>	4
20	<p>Ans</p> <p>(a)These bright circular patches are the pinhole images of the sun.</p> <ul style="list-style-type: none"> • Small gaps between the leaves act as pinholes. • Sunlight passes through these pinholes to form bright circular images of the sun on the ground (any correct point) <p>b. The screen was very far from the object.</p> <p>c Shadows are erect but images are inverted (1+1+2)</p>	4

Q NO	QUESTIONS	MARKS
SECTION-A		
1.	Which type of energy conversion takes place in an electric cell. a. Electrical to light b. light to electrical (c) Chemical to electrical (d) light to chemical	1
2.	Filament of a bulb is made of which element? a. Aluminium b. Tungsten c. Platinum d. Gold	1
3.	Identify the number of terminals in the electric cells  (a) 1 (b) 2 (c) 3 (d) 4	1
4.	Identify the incorrect statement. (a) Metal cap is positive terminal of the electric cell (b) The metal disc is the negative terminal. (c) all electric cells have two terminals, a positive and negative terminal. (d) The metal disc is the positive terminal.	1
5.	A substance which allows electricity to pass through it is called... (a) a conductor (b) an insulator (c) semiconductor (d) superconductor	1
6.	To prevent electric shocks, the metallic electrical wire are covered with (a) paper (b) cotton (c) aluminium (d) plastic	1
7.	Combination of two or more cells is called...? (a) battery (b) cell (c) bulb (d) circuit	1
8.	Question No. 8 consists of two statements – Assertion (A) and Reason (R). Answer these questions selecting the appropriate option given below: a) Both A and R are true, and R is the correct explanation of A. b) Both A and R are true, and R is not the correct explanation of A.	1

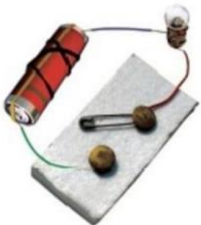
	<p>c) A is true but R is false. d) A is false but R is true. Assertion (A): - Insulators do not allow the current to flow through them. Reason (R): - They are poor conductors of electricity.</p>	
SECTION-B		
9.	Can rubber or jute be used instead of metal wire to connect circuit?	2
10.	Name two metals which can be used to connect wires.	2
11.	Why is a copper wire usually covered with rubber or plastic?	2
12.	Draw a diagram showing the two terminals of a bulb.	2
13.	Draw a circuit using a cell, a bulb, connecting wires and a switch.	2
SECTION-C		
14.	Why are we advised not to touch electric appliances and switches with wet hands?	3
15.	Define conductors and insulators. Give one example of each.	3
16.	Give one activity to prove that air is an insulator.	3
SECTION-D		
17.	<p>(a) An electric bulb is connected to a cell through a switch as shown in fig. When the switch is brought ON position the bulb does not glow. What could be the possible reasons for it? Mention any three of them. ■</p>  <p>(b) Identify conductors and insulators from the following; Eraser, paper, matchstick, copper wire, pencil lead, polythene</p>	5(3+2)
18	<p>(a) If you touch an electric wire carrying current you get a shock, but if on the same wire the birds sit they do not get any shock. Explain why? (b) Would the bulb glow in the below mentioned circuit?</p> 	5(3+2)
SECTION E		
19	<p>Read the following passage and answer the following question. An electric bulb has a filament that is connected to the terminals. The two terminals of filament are fixed with two thick wires that provide support to it. These terminals are fixed in such a manner that they do not touch each other.</p> <p>(a) A thin wire that gives off light when the bulb is switched on is known as..... (b) What is the direction of flow of current in a dry cell?</p>	4 (1+1+2)

	<p>(c) Will the bulb glow in the circuit shown in the given figure? Give a reason.</p> 	
20	<p>The electric circuit provides a complete path for electricity to pass (current to flow) between the two terminals of the electric cell. The bulb glows only when current flows through the circuit. In an electric circuit, the direction of current is taken to be from the positive to the negative terminal of the electric cell.</p> <p>(i) What is an open circuit? (ii) Which type of materials is used in electric appliances as protective measures? (iii) Choose from the options (a), (b), (c) and (d) given below the figure which shows the correct direction of current. Give a reason. █</p> 	4 (1+1+2)

ANSWER KEY

CLASS-VI

TOPIC – ELECTRICITY & CIRCUIT



Q NO	ANSWER	MARKS
SECTION-A		
1	c) Chemical to electrical	1
2	b) Tungsten	1
3	b) 2	1
4	d) The metal disc is the positive terminal	1
5	. A conductor	1
6	d) Plastic	1
7	. Battery	1
8	. Both A and R are true, and R is the correct explanation of A.	1
SECTION-B		
9	No, we cannot use rubber or jute to connect circuit wire. Because they are insulators.	2

10	Copper, aluminium	2
11	Rubber or plastics are insulators. They prevent short circuiting or electric shocks.	2
12	NCERT page no-96 correct diagram	2
13	NCERT page no-99 correct diagram	2
SECTION-C		
14	Because water is a good conductor of electricity and if our hands are wet current can pass to us quickly giving us an electric shock.	3
15	A conductor is that which easily allows the passage of current through it. Example: Aluminium or any metal. An insulator is that which does not allow the passage of current through it. Example: Rubber.	3
16	Take an electric circuit, keep the terminals unconnected in the air. The bulb does not glow, as air is an insulator and does not allow the current to flow through it.	3
SECTION-D		
17	a. (i) Loose connections (ii) connection wire are broken (iii) The cell is a used one (iv) The bulb is fused. (any three) b. Insulators- Eraser, paper, matchstick, polythene Conductor- copper wire, pencil lead	3 2
18.	(a) When we hold the wire carrying current then the circuit is closed and the current flows from our body and enters earth but the birds sitting on the same wire do not get any current as the circuit is not complete. If the bird touches the earth wire, it will also die due to electric shock. (b) No, the bulb will not glow. Because both the wires are connected to the same terminal of the bulb.	3 2
19	(a) Filament (b) Positive to negative (c) No, the bulb will not glow in the circuit because the switch is open and the circuit is broken.	1 1 2
20	(i) when there is a gap between two terminals, the circuit is called an open circuit. (ii) Insulators (iii) b is correct. Current always starts from the positive terminal and ends at the negative terminal of the battery.	1 1 2

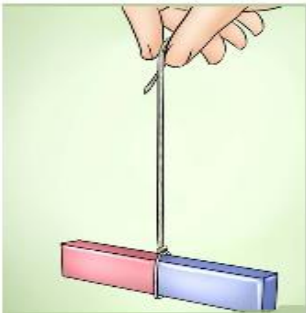
CHAPTER 13 FUN WITH MAGNETS

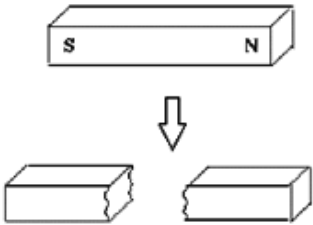
Q NO	QUESTIONS	MARKS
	SECTION-A	
1.	<p>Which is an example of a magnetic substance?</p> <p>a. Wood</p> <p>b. plastic</p> <p>c. paper</p> <p>d. Iron</p>	1
2.	 <p>A freely suspended bar magnet rests in..... direction?</p> <p>(a) East- west</p> <p>(b) upside</p> <p>(c) north-south</p> <p>(d) downside</p>	1
3.	<p>The magnetic properties of a magnet cannot be destroyed by?</p> <p>a. washing</p> <p>b. Heating</p> <p>c. Dropping on a hard surface</p> <p>d. Hammering</p>	1
4.	<p>Device used by pilots and navigators used to find the direction</p> <p>a. Thermometer</p> <p>b. lactometer</p> <p>c. Magnetic compass</p> <p>(d) all of above</p>	1
5.	<p>Which of the following is an artificial magnet?</p> <p>a. Horse shoe magnet</p> <p>b. Bar magnet</p> <p>c. cylindrical magnet</p> <p>(d) All of above</p>	1
6.	<p>The two ends of magnet are called.....?</p> <p>a. poles</p>	1

	<p>b. terminal</p> <p>c. south</p> <p>d. North</p>	
7.	<p>Which of the following items cannot be picked by a magnet.</p> <p>a. Paper clip</p> <p>b. Aluminium foils</p> <p>c. Iron nails</p> <p>d. Hair pins</p>	1
8.	<p>Question consist of two statements – Assertion (A) and Reason (R). Answer these questions selecting the appropriate option given below:</p> <p>a) Both A and R are true, and R is the correct explanation of A.</p> <p>b) Both A and R are true, and R is not the correct explanation of A.</p> <p>c) A is true but R is false.</p> <p>d) A is false but R is true.</p> <p>Assertion (A) The north pole of a freely suspended magnet points towards geographic north.</p> <p>Reason (R) Earth has two poles.</p>	1
SECTION-B		
9.	<p>Categorise the given substances into two groups magnetic and non-magnetic.</p> <p>Key, Rubber, Sand, chalk</p>	2
10.	 <p>Observe the image and write any four types of magnet. Name the type of magnet which is used speaker</p>	2
11.	<p>Mohan dipped a bar magnet in a heap of iron filing and pulled it out. He found that iron filings got stuck to the magnet.</p> <p>(i) Which regions of the magnet have more iron filings sticking to it?</p> <p>(ii) What are these regions called?</p>	2
12.	 <p>Arun broke a bar magnet accidentally into two piece. Redraw the diagram indicating north and south pole of the pieces.</p>	2
13.	<p>List any two properties of magnet which are useful in daily life.</p>	2
SECTION-C		

14.	(i) What happens when similar poles of a magnet come closer? (ii) How should we keep a horse shoe magnet to prevent it from demagnetising?	3
15.	 <p>Identify the magnetic and non-magnetic materials.</p>	3
16.	 <p>(a) Observe the picture and find out whether the car is moving away or coming closer. Why? (b) Mention any two precaution while handling the magnet.</p>	3
SECTION-D		
17.	<p>Read the following passages answer the questions.</p> <p>(A) A shepherd named Magnus lived in Greece used to take his herd of sheep's and goats on a mountain for grazing. He always carried a stick to control his herd. The stick had a small piece of iron attached to one end. One day he had to pull hard to free his stick from a rock on the mountain side.</p>  <p>Source :https://www.wikiart.org/en/hugo-muhlig/field-landscape-with-shepherd-boy-dog-and-flock-of-sheep</p> <p>(i) The credit for discovery of natural magnet goes to.....? (ii) Another name of natural magnet is _____ (iii) List any two properties of magnet.</p>	1 1 2
18.	Read the following passages to answer the questions.	

	<p>A) We understand that magnet attracts certain materials whereas some do not get attracted towards magnet. The materials which get attracted towards a magnet are magnetic – for example, The materials which are not attracted towards a magnet are non-magnetic.</p>  <p>(i) In which part of a magnet is the magnetic force the maximum? (ii) In which direction does a suspended magnet come to rest? (iii) What happens when N- pole of a magnet is brought near the N- pole of a suspended magnet?</p>	1 1 2
19.	<p>(i) What is the principle on which magnetic compass work? (ii) Draw and label the parts of a magnetic compass. (ii) It is advised to keep the magnets away from television, mobile, CD, and computer explains why?</p>	1 2 2
20.	How can you make an iron strip into a bar magnet? Explain with help of suitable diagrams.	5



ANSWER KEY FUN WITH MAGNETS

Q NO	ANSWER	MARKS
SECTION-A		
1	d	1
2	c	1
3	a	1
4	c	1
5	d	1
6	a	1
7	b	1
8	b	1
SECTION-B		
9.	Correct answer $1/2 \times 2 = 2$	2
10.	correct answer ,Ring magnet	1+1
11.	(i) More iron fillings will be attached towards the ends of the bar magnet. (ii) End of magnet are north pole and south pole	2
12.	The magnet always consists of poles in pairs, i.e. the north pole and the south pole. Correct diagram with two poles	2
13.	Magnets can be used to separate magnetic materials such as iron from the non-magnetic ones. Magnetic compass can be used to know the directions.	2
SECTION C		
14.	(i) When similar poles come closer they repel each other.	3

	(ii) for horse shoe magnet one should keep a piece of iron across the poles.	
15.	Correct identification $\frac{1}{2} \times 6 = 3$	3
16.	correct answer (1+2) any two correct precautions.	3
SECTION D		
17.	A(i) Magnus (ii) Magnetite (iii) Any 2 properties	1 1 2
18.	A(i) poles (ii) N-S direction (iii) repel each other	1 1 2
SECTION E		
19.	(i) When a bar magnet moves or rotates freely, it comes to rest in a north - south direction. This is the principle on which magnetic compass works. (ii) Diagram with any 2 parts labelled correctly  (ii) Television, mobiles, CD, computers and many more devices are made up of magnetic materials and magnets in them. If you bring a magnet closer to it then it will spoil these devices.	1 2 2
20.	Take a bar magnet and place its pole near one edge of the iron bar. Without lifting the bar magnet, move it along the length of iron bar. Move the magnet again along the iron bar. Repeat it 30-40 times. Check whether it has become a magnet. If not, continue the process for some more time. Diagram ncert text book page no-110	3

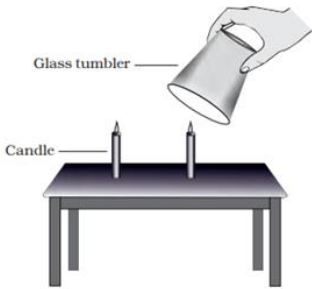
Q NO	SECTION A	MARKS
1	<p>The component of air which is necessary for respiration of living Organism is</p> <p>(a) Nitrogen (b) oxygen (c) Hydrogen (d) water vapour</p>	1
2	<p>The component of air which neither burns itself nor supports burning is</p> <p>(a) Oxygen (b) Hydrogen (c) Nitrogen (d) none of these</p>	1
3	<p>Madhu took a dry tumbler and put some ice in it. She observed small droplets of water on the outer surface of the tumbler. What do you infer from this observation?</p> <p>(a) water vapor is present in air (b) carbon dioxide is present in air (c) nitrogen is present in air (d) oxygen is present in air</p>	1
4	<p>Plants and animals consume oxygen for respiration and give out__</p> <p>(a) Carbon dioxide (b) Nitrogen (c) Water vapour (d) methane</p>	1
5	<p>Aquatic animals use</p> <p>(a) Oxygen dissolved in water for respiration (b) Nitrogen dissolved in water for respiration (c) Carbon dioxide dissolved in water for respiration (d) Oxygen dissolved in water for photosynthesis</p>	1
6	<p>The picture given below shows a paper toy called firki. It is moving. Can</p> <div data-bbox="794 1375 995 1630" style="text-align: center;">  </div> <p>you predict what makes the firki move?</p> <p>(a) Moving air (b) Electricity (c) Rain (d) Thunder</p>	1
7	<p>Which of the following statements about Carbon dioxide gas is not correct?</p> <p>(a) Due to excess carbon dioxide accumulation in the room suffocation may happen (b) Carbon dioxide makes up the largest component of the air around us. (c) Plants and animals consume oxygen for respiration and produce carbon dioxide.</p>	1

	(d) Plant and animal matter consume oxygen on burning and produce mainly carbon dioxide.											
8	<p>During an incident of fire, one is advised to wrap a woollen blanket over a burning object? The correct justification would be</p> <p>(a) The supply of oxygen is cut off by wrapping the blanket, to extinguish the fire</p> <p>(b) The supply of carbon dioxide is cut off by wrapping the blanket, to extinguish the fire</p> <p>(c) The blanket is wrapped to prevent the object from breaking</p> <p>(d) The supply of oxygen is increased by wrapping the blanket, to extinguish the fire</p>	1										
SECTION B												
9	What are the two uses of a windmill?	2										
10	What is the composition of air?	2										
11	<p>Match the columns</p> <table border="1" style="width: 100%;"> <thead> <tr> <th style="width: 50%;">COLUMN I</th> <th style="width: 50%;">COLUMN II</th> </tr> </thead> <tbody> <tr> <td>(a) Oxygen</td> <td>(i) Harmful for our health</td> </tr> <tr> <td>(b) Nitrogen</td> <td>(ii) Drops of water appear on cool surfaces</td> </tr> <tr> <td>(c) Dust and Smoke</td> <td>(iii) Does not support burning</td> </tr> <tr> <td>(d) Water vapour</td> <td>(iv) Needed for burning of objects</td> </tr> </tbody> </table>	COLUMN I	COLUMN II	(a) Oxygen	(i) Harmful for our health	(b) Nitrogen	(ii) Drops of water appear on cool surfaces	(c) Dust and Smoke	(iii) Does not support burning	(d) Water vapour	(iv) Needed for burning of objects	2
COLUMN I	COLUMN II											
(a) Oxygen	(i) Harmful for our health											
(b) Nitrogen	(ii) Drops of water appear on cool surfaces											
(c) Dust and Smoke	(iii) Does not support burning											
(d) Water vapour	(iv) Needed for burning of objects											
12	How do organisms living in the soil respire? Name two organisms which lives inside soil.	2										
13	List any four activities that are possible due to the presence of air.	2										
SECTION C												
14	<p>Take some water in a glass or metal container. Heat it slowly on a tripod stand. Well before the water begins to boil, look carefully at the inside of the container. Tiny bubbles are seen on the inside surface of the container.</p> <p>(a) Why do we see those tiny bubbles on slight heating of water?</p> <p>(b) Why aquatic animals breathe faster?</p>	3										
												
15	<p>Fix two small candles of the same length on a table. Light both the candles. Cover one of the candles with an inverted glass tumbler. It is observed that one of the candles goes off.</p>	3										
												
(a) Which candle do you think goes off?												

	(b) What could be the possible reason for your observation?	
16	How do plants and animals help each other in the exchange of gases in the atmosphere?	3
SECTION D		
17	<p>(a) Dip the open mouth of an empty bottle into the bucket filled with water as shown in the figure below. It is observed that the water does not enter the bottle. Can you justify the observation?</p> <p>(b) Now tilt the bottle slightly. The water now enters the bottle. Justify why the water enters the bottle when tilted? What are the bubbles coming out of the bottle? Why are the bubbles seen?</p>	5
		
18	<p>Give reason for the following observations in brief:</p> <p>(a) During storms the trees may uproot and the rooftops may blow off</p> <p>(b) Bubbles are seen coming out when water is poured on a lump of dry soil.</p> <p>(c) An empty tumbler in fact is not empty.</p> <p>(d) Mountaineers carry oxygen cylinders with them</p> <p>(e) We should never sleep in a completely closed room.</p>	5
SECTION E		
19	<p>Read the given paragraph and answer the questions that follow</p>  <p>Air pollution is caused by harmful smoke and fumes as also particulate matter from various sources such as exhausts of vehicular traffic, factories, burning of fossil fuels, burning of garbage and farm refuse, and construction sites. Air pollution is a big health hazard causing several diseases in humans. It affects the respiratory and cardiac systems of the human body, and also affects the eyes and other organs of the body. Millions of people die each year due to air pollution. We need to take stringent measures urgently to curb air pollution and improve the quality of the air we breathe.</p> <p>(1) Why are the chimneys of the factories made tall?</p> <p>(2) Breathing through your mouth is not advisable. Why?</p> <p>(3) Evaluate the effect of air pollution on human health.</p>	4

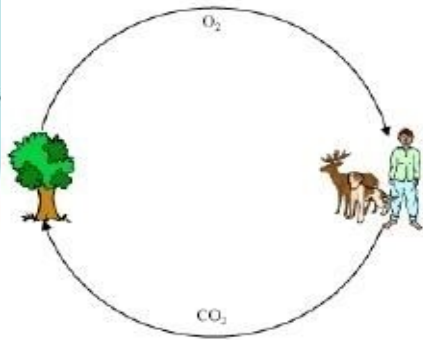

Photosynthesis is the process in which green plants use sunlight to make their own food. Photosynthesis is necessary for life on Earth. Without it there would be no green plants, and without green plants there would be no animals.

Photosynthesis requires sunlight, chlorophyll, water, and carbon dioxide gas. Chlorophyll is a substance in all green plants, especially in the leaves. Plants take in water from the soil and carbon dioxide from the air.

Photosynthesis starts when chlorophyll absorbs energy from sunlight.

Green plants use this light energy to change water and carbon dioxide into oxygen and nutrients called sugars. The plants use some of the sugars and store the rest. The oxygen is released into the air.

Photosynthesis is very important because almost all living things depend on plants for food. Photosynthesis is also important because of the oxygen it produces. Humans and other animals need to breathe in oxygen to survive.

Some living things other than plants also make their own food through photosynthesis. They include certain types of bacteria and algae.

- (i) Which component of air is needed by green plants for photosynthesis?
- (ii) Which component of air is needed by living organisms for respiration?
- (iii) Evaluate role of trees in maintaining quality of life.

Q NO	SECTION A	MARKS										
1	(b) oxygen	1										
2	c	1										
3	(a) water vapor is present in air	1										
4	(a) Carbon dioxide	1										
5	(a) Oxygen dissolved in water for respiration	1										
6	(a) Moving air	1										
7	(b) Carbon dioxide makes up the largest component of the air around us.	1										
8	(a) The supply of oxygen is cut off by wrapping the blanket, to extinguish the fire	1										
SECTION B												
9	(i) The windmill is used to draw water from tube wells and to run flour mills. (ii) Windmills are also used to generate electricity.	1+1										
10	Oxygen and Nitrogen gases together make up 99% of the air. The remaining 1% is constituted by carbon dioxide and a few other gases and water vapour	2										
11	Match the columns <table border="1" style="width: 100%; border-collapse: collapse;"> <thead> <tr> <th style="width: 50%;">COLUMN I</th> <th style="width: 50%;">COLUMN II</th> </tr> </thead> <tbody> <tr> <td>(a) Oxygen</td> <td>(iv) Needed for burning of objects</td> </tr> <tr> <td>(b) Nitrogen</td> <td>(iii) Does not support burning</td> </tr> <tr> <td>(c) Dust and Smoke</td> <td>(i) Harmful for our health</td> </tr> <tr> <td>(d) Water vapour</td> <td>(ii) Drops of water appear on cool surfaces</td> </tr> </tbody> </table>	COLUMN I	COLUMN II	(a) Oxygen	(iv) Needed for burning of objects	(b) Nitrogen	(iii) Does not support burning	(c) Dust and Smoke	(i) Harmful for our health	(d) Water vapour	(ii) Drops of water appear on cool surfaces	$\frac{1}{2} * 4 = 2$
COLUMN I	COLUMN II											
(a) Oxygen	(iv) Needed for burning of objects											
(b) Nitrogen	(iii) Does not support burning											
(c) Dust and Smoke	(i) Harmful for our health											
(d) Water vapour	(ii) Drops of water appear on cool surfaces											
12	There is air in between the soil particles. Also, a lot of burrows and holes are formed in deep soil by the animals living in the soil. These burrows make spaces available for air to move in and out of the soil. The organisms living in the soil respire in this air. Any two soil organisms.	2										
13	(i) Air helps in the movements of sailing yachts, gliders, parachutes and aeroplanes. (ii) Birds, bats and insects can fly due to the presence of air. (iii) Air plays an important role in the dispersal of seeds and pollen of flowers of many plants. (iv) Water cycle cannot take place in absence of air. (v) Components of air (oxygen) are required for respiration of organisms and photosynthesis of plants (Carbon dioxide). (Any four points)	$\frac{1}{2} * 4 = 2$										
SECTION C												
14	(a) The tiny bubbles are of the air dissolved in water. When we heat the water, the air dissolved in it escapes forming the bubbles. (b) Aquatic plants and animals use this dissolved air/ oxygen for respiration/amount of oxygen dissolved in water is less when compared to the amount in air	2 1										
15	(a) The candle which is covered by an inverted tumbler will go off in a few seconds. (b) There is a component in air which is necessary for objects to burn. That is oxygen. The candle which is not covered continues to burn as it gets continuous supply of oxygen-but the supply of oxygen gets cut off on covering the candle with the tumbler and the candle goes off.	1 2										

16	(i) The balance of oxygen and carbon dioxide in the atmosphere is maintained through respiration in plants and animals and by photosynthesis in plants. This shows the interdependence of plants and animals (ii) The plants use carbon dioxide produced during respiration by animals for photosynthesis and they release oxygen as a by-product of photosynthesis which in turn is used by animals and plants for respiration.	1.5 1.5
SECTION D		
17	(a) The bottle we take looks empty but is not empty at all. It is filled completely with air even when we turn it upside down. That is why we see that water does not enter the bottle when it is pushed in an inverted position, as there is no space for air to escape. Hence water cannot enter this bottle. (b) When the bottle is tilted, the air comes out in the form of bubbles, and water fills up the empty space that the air had occupied. This activity shows that air occupies space. It had filled all the space in the bottle.	2.5 2.5
18	(a) During storms the trees may uproot and the rooftops may blow off because during storms the wind blows at a very high speed. (b) Bubbles are seen coming out when water is poured on a lump of dry soil because air is trapped between the particles of soil. This air escapes in the form of bubbles when water is poured on a dry lump of soil. (c) An empty tumbler in fact is not empty, it is full of air. (d) Mountaineers carry oxygen cylinders with them because as we climb to higher altitudes air becomes less and less hence oxygen in the surrounding air is not enough for us to breathe. (e) We should never sleep in a completely closed room because in a closed room, if there is some material that is burning, we may feel suffocated. This is due to excess carbon dioxide that may be accumulating in the room.	1 1 1 1 1
SECTION E		
19	(i) Factories produce smoke containing harmful gases and dust particles. That is why we see long chimneys in factories. These take the harmful smoke and gases away from our noses high up in the air so that we do not breathe this smoke. (2) If you are breathing air full of smoke, it is better to breathe through nostrils as there is fine hair and mucus in the nostrils which will trap the dust particles and prevent them from entering our lungs. (3) The respiratory and cardiac systems of the human body are affected	1 2 1
20	(i) Carbon dioxide is needed by green plants for photosynthesis. (ii) Oxygen is needed by living organisms for respiration. (iii) Reduce air pollution, absorbs sound and reduce noise pollution, enrich water table or any other	1 1 1x2

THANK YOU.....