

Notice inviting public comments

Draft of Rights of Persons with Disabilities (Amendment) Rules, 2023 on accessibility standards for **sports sector** are hereby notified inviting comments from the general public and other stakeholders. Objections and suggestions, if any, may be addressed to Shri Nithali Ram, Deputy Secretary to the Government of India, Department of Empowerment of Persons with Disabilities (Divyangjan), Room No 523, 5th Floor, Pandit Deen Dayal Antyodaya Bhawan, CGO Complex, Lodhi Road, New Delhi, 110003 or **by email at nithali.ram@nic.in**, by **10th June 2023**.



भारत का राजपत्र The Gazette of India

सी.जी.-डी.एल.-अ.-01052023-245552
CG-DL-E-01052023-245552

असाधारण
EXTRAORDINARY

भाग II—खण्ड 3—उप-खण्ड (i)
PART II—Section 3—Sub-section (i)

प्राधिकार से प्रकाशित
PUBLISHED BY AUTHORITY

सं. 265]
No. 265]

नई दिल्ली, सोमवार, मई 1, 2023/वैशाख 11, 1945
NEW DELHI, MONDAY, MAY 1, 2023/VAISAKHA 11, 1945

सामाजिक न्याय और अधिकारिता मंत्रालय
(दिव्यांगजन सशक्तिकरण विभाग)
अधिसूचना

नई दिल्ली, 28 अप्रैल, 2023

सा.का.नि. 335(अ).—दिव्यांगजन अधिकार नियम, 2017 में संशोधन करने के लिए कतिपय नियमों का निम्नलिखित मसौदा, जिन्हें दिव्यांगजन अधिकार अधिनियम, 2016 (2016 का 49) की धारा 100 की उप-धारा (1) और (2) द्वारा प्रदत्त शक्तियों का प्रयोग करते हुए केन्द्रीय सरकार का प्रस्ताव प्रकाशित करने का है, इसके द्वारा प्रभावित होने वाले संभावित व्यक्तियों की सूचना के लिए उक्त धारा की उप धारा (1) द्वारा यथा अपेक्षित अनुसार एतद्वारा प्रकाशित किया जाता है और एतद्वारा नोटिस दिया जाता है कि आधिकारिक राजपत्र की प्रतियाँ जिसमें यह अधिसूचना प्रकाशित की गई है और जनता को उपलब्ध करा दी गई है उस तारीख से 30 दिन की अवधि की समाप्ति के पश्चात उक्त मसौदा नियमों पर विचार किया जाएगा ;

उक्त मसौदा नियमों के संबंध में उपरोक्त विनिर्दिष्ट अवधि की समाप्ति से पूर्व किसी भी व्यक्ति से प्राप्त होने वाली आपत्तियों और सुझावों पर केंद्र सरकार द्वारा विचार किया जाएगा;

आपत्तियां और सुझाव, यदि कोई हो, को श्री निठाली राम, उप सचिव, भारत सरकार, दिव्यांगजन सशक्तिकरण विभाग, कमरा नंबर 523, 5वां तल, पंडित दीन दयाल अन्त्योदय आपत्तियां और सुझाव, यदि कोई हो, को श्री निठाली राम, उप सचिव, भारत सरकार, दिव्यांगजन सशक्तिकरण विभाग, कमरा नंबर 523, 5वां तल, पंडित दीन दयाल अन्त्योदय भवन, सीजीओ कॉम्प्लेक्स, लोधी रोड, नई दिल्ली, 110003 को या nithali.ram@nic.in पर ईमेल द्वारा

भेजा जा सकता है। भवन, सीजीओ कॉम्प्लेक्स, लोधी रोड, नई दिल्ली, 110003 को या nithali.ram@nic.in पर ईमेल द्वारा भेजा जा सकता है।

मसौदा नियम

संक्षिप्त शीर्षक और विस्तार.—(1) इन नियमों को दिव्यांगजन अधिकार (संशोधन) नियम, 2023 कहा जाएगा।

(2) ये राजपत्र में इनके प्रकाशन की तारीख से लागू होंगे।

दिव्यांगजन अधिकार नियम, 2017 में, नियम (15) में, उप-नियम (1) में, खंड (घ) के बाद, निम्नलिखित खंड अंतःस्थापित किया जाएगा, अर्थात्: -

"(ड) खेल-विभाग में भारत सरकार की अधिसूचना संख्या 7-6/एमवाइएस/एमडीएसडी/2021, दिनांक 13 अक्टूबर, 2022 में दिव्यांग खिलाड़ियों के लिए सुगम्य खेल परिसर और आवासीय सुविधाओं पर यथानिर्दिष्ट दिशानिर्देश।"

[फा. सं. 38-15/2022-डीडी-III]

राजेश कुमार यादव, संयुक्त सचिव

नोट : दिव्यांगजन अधिकार अधिनियम, 2017 भारत के राजपत्र, असाधारण, भाग II, खंड 3, उपखंड (i) में अधिसूचना संख्या सा.का.नि. 591(असा.), दिनांक 15 जून, 2017 द्वारा प्रकाशित किए गए थे और जीएसआर 181(अ), दिनांक 17 मार्च, 2020 द्वारा अंतिम बार संशोधित किया गया था।

MINISTRY OF SOCIAL JUSTICE AND EMPOWERMENT

(Department of Empowerment of Persons with Disabilities)

NOTIFICATION

New Delhi, the 28th April, 2023

G.S.R. 335(E).—The following draft of certain rules to amend the Rights of Persons with Disabilities Rules, 2017, which the Central Government proposes to make in exercise of the powers conferred by sub-sections (1) and (2) of section 100 of the Rights of Persons with Disabilities Act, 2016 (49 of 2016), is hereby published as required by sub-section (1) of the said section, for the information of all persons likely to be affected thereby; and notice is hereby given that the said draft rules shall be taken into consideration after the expiry of a period of thirty days from the date on which the copies of the Official Gazette in which this notification is published are made available to the public;

Objections and suggestions, if any, may be addressed to Shri Nithali Ram, Deputy Secretary to the Government of India, Department of Empowerment of Persons with Disabilities (Divyangjan), Room No 523, 5th Floor, Pandit Deen Dayal Antyodaya Bhawan, CGO Complex, Lodhi Road, New Delhi, 110003 or by email at nithali.ram@nic.in;

The objections and suggestions, which may be received from any person with respect to the said draft rules before the expiry of the period specified above, will be considered by the Central Government.

DRAFT RULES

- Short title and extent.**—(1) These rules may be called the Rights of Persons with Disabilities (Amendment) Rules, 2023.
- They shall come into force from the date of their publication in the Official Gazette.
- In the Rights of Persons with Disabilities Rules, 2017, in rule (15), in sub-rule (1), after clause (d), the following clause shall be inserted, namely:-

“(e) Guidelines on Accessible Sports Complex and Residential Facilities for Sports Persons with Disabilities as specified in the notification of the Government of India in the Department of Sports, *vide* number No. 7-6/MYAS/MDS/2021, dated the 13th October, 2022.”

[F. No. 38-15/2022-DD-III]

RAJESH KUMAR YADAV, Jt. Secy.

Note : The Rights of Persons with Disabilities Rules, 2017 were published in the Gazette of India, Extraordinary, Part II, section 3, sub-section (i) *vide* notification number G.S.R. 591 (E), dated the 15th June, 2017 and was last amended *vide* G.S.R. 181 (E), dated the 17th March, 2020.

अनुसार प्रदान और अनुकूलित किया जाना चाहिए। ऐसे कोच/गाइड होंगे जो निरंतर/आवश्यकता के आधार पर समायोजनों का सत्यापन और समर्थन करेंगे।

21.10 आपदा प्रबंधन योजना

- सभी प्रवेश और निकास बिंदुओं को अच्छी तरह से प्रदर्शित किया जाएगा
- अग्निशामक यंत्र और निकास योजना ब्रेल में होनी चाहिए और ऑडियो संस्करण उपलब्ध कराया जाएगा

21.11 जांच सूची- सूचना और संचार

1.क	भवन/सेवा के बारे में जानकारी प्रदान करने वाली वेबसाइट वेब सुलभता मानकों का अनुपालन करती है।
1.ख	चित्रलेख के साथ भवन में सुलभ सुविधाओं के विवरण की सूचना दी गयी है।
2.	सभी प्रकाशन/ब्रोशर वैकल्पिक सुलभ प्रारूपों में उपलब्ध हैं जैसे: ब्रेल/बड़े प्रिंट/ऑडियो/चित्रकारी/पढ़ने में आसान/साधारण भाषा/हिंदी और अंग्रेजी और स्थानीय भाषा में उपलब्ध। - सुलभ इलेक्ट्रॉनिक प्रारूप जिन्हें ईमेल या मोबाइल प्लेटफॉर्म पर साझा किया जा सकता है।
3	मुद्रित सेवा से संबंधित दस्तावेज़ जैसे प्रपत्र; मेनू कार्ड, आदि सुलभ प्रारूपों में हैं।
4.	फॉर्म को सुलभ सॉफ्टवेयर के माध्यम से इलेक्ट्रॉनिक रूप से भरा जा सकता है।
5.	यदि आवश्यक हो तो लिखित प्रपत्र भरने के लिए अतिरिक्त सहायता उपलब्ध है।
6.	स्टाफ को भारतीय संकेत भाषा की व्याख्या में प्रशिक्षित किया गया है। यदि नहीं, तो कॉल पर संकेत भाषा के व्याख्याकर्ता उपलब्ध हैं।
7	सहायक तकनीक जैसे लूप इंडक्शन सिस्टम, ऑडियो ओरिएंटेशन टूल, कैप्शनिंग या संकेत भाषा के साथ व्याख्यात्मक वीडियो, व्हीलचेयर आदि उपलब्ध हैं।
8.	कम दृष्टि वाले व्यक्तियों और श्रवण बाधित व्यक्तियों के लिए पर्याप्त और एक समान प्रकाश व्यवस्था और कोई चमक नहीं या काले धब्बे नहीं हैं की स्थिति हो।
9.	उपरोक्त सभी प्रावधानों में विभिन्न संस्कृतियों, अभिगम की अक्षमता वाले व्यक्तियों, औपचारिक रूप से शिक्षित नहीं होने वाले व्यक्तियों के लिए पर्याप्त सहायता उपलब्ध है।
10.	आगंतुकों/दिव्यांगजनों के लिए शिकायत दर्ज करने या सुझाव देने की एक प्रक्रिया है।

MINISTRY OF YOUTH AFFAIRS AND SPORTS

(Department of Sports)

NOTIFICATION

New Delhi, the 13th October, 2022

SUBJECT : Guidelines on Accessible Sports Complex and Residential Facilities for Sports Persons with Disabilities - reg.

No. 7-6/MYAS/MDSD/2021.—Whereas Section 40 of the Rights of Persons with Disabilities Act 2016 (hereinafter, referred as the Act) mandates the Central Government, in consultation with the Chief Commissioner, to formulate rules laying down standards of accessibility inter-alia for facilities and services provided to the public in urban and rural areas;

2. And whereas, Department of Sports, Ministry of Youth Affairs and Sports is the nodal Central Department w.r.t. issues concerning sports sector and accordingly, developed guidelines specifying standards for accessible sports complex and residential facilities for sports persons with disabilities in consultation with stakeholders and office of Chief Commissioner for Persons with Disabilities.

3. Now, Department of Sports, Ministry of Youth Affairs and Sports hereby notifies the “Guidelines for Accessible Sports Complex and Residential Facilities for Sports Persons with Disabilities’ as detailed at Annexure.

KUNAL, Jt. Secy.

Guidelines

Accessible Sports Complex and Residential Facilities for Sports Persons with Disabilities

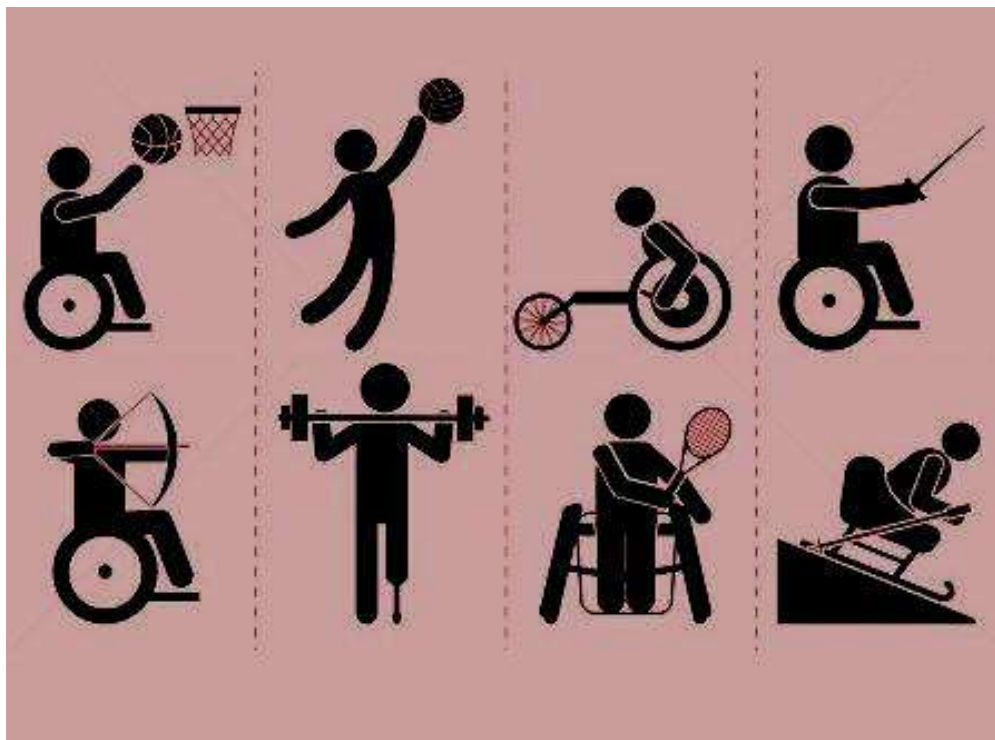

**Mission Directorate Sports Development,
Department of Sports, Ministry of Youth Affairs & Sports,
Government of India**
Tel No. 011-2436-1823
Email Id: mdsd-myas@gov.in

Contents

Glossary.....	
Introduction.....	
Universal Design.....	
Why Universal Design.....	
About the Guidelines.....	
Approach.....	
Accessible Parking.....	
Main Entrance.....	
5. Signage.....	
5.1 Identification Signs.....	
5.2 Directional Signs.....	
5.3 Regulatory Signs.....	
5.4 Temporary Signs.....	
6. Reception / Enquiry Counter.....	

Ramp.....	
Steps and Staircase.....	
Handrails.....	
Lift.....	
Doors.....	
Door Accessories and Hardware.....	
Corridors.....	
13.1 Floor Finishes.....	
Switch Boards.....	
14.1 Illumination.....	
General Toilets.....	
Accessible Toilet, Change Room and Bathroom.....	
16.1 Water Closet (WC).....	
16.2 Washbasin.....	
16.3 Bathroom/ Changing Room.....	
16.4 Squatting Seat.....	
Spectator Seating Area.....	
Residential Facilities	
18.1 Windows.....	
18.2 Fittings.....	
18.3 Bed.....	
18.4 Multi-use Tables.....	
18.5 Storage Space.....	
18.6 Dining Area.....	
19. Luminosity Contrast.....	
20. Emergency Evacuation.....	
20.1 Safety.....	
20.2 Refuge.....	
20.3 Evacuation Route.....	
21. Accessible Information & Communication, Services and Facilities.....	

Glossary

Access Aisle

An accessible pedestrian space between elements, such as parking spaces, seating and desks that provides clearances appropriate for use of elements

Accessible

A site, building, facility, or portion thereof that complies with this guideline and that can be approached, entered and used by people with disabilities

Accessible Route

A continuous unobstructed path connecting all accessible elements and spaces in a building that can be negotiated by a person with disability using a wheelchair, is safe for and usable by, people with other disabilities

- Interior accessible routes may include corridors, ramps, elevators, lifts, and unobstructed floor space, etc.
- Exterior accessible routes may include parking, access aisles, kerb ramps, walkways and ramps

Beveled

Smooth, slanted angle between two surfaces; for example, a slope or inclination between two uneven surfaces to allow easier passage of a wheelchair

Circulation Path

An exterior or interior way of passage from one place to another for pedestrians including walkways, hallways, courtyards, stairways and stair landings

Kerb

A side barrier to a trafficable surface

Kerb Ramp

A short ramp cutting through a kerb or built up to it

Grab Bars

A bar used to give a steadying or stabilizing assistance to a person engaged in a particular function

Handrails

A rail used in circulation areas such as corridors, passageways, ramps and stairways to assist in continuous movement

Bathroom cum Toilet

A cubicle having basic requirements of a water closet compartment, washbasin and other essential toilet accessories

LRV

Light Reflectance Value (LRV) is the total quantity of visible light reflected by a surface at all wavelengths and directions when illuminated by a light source

Luminosity Contrast

Also known as tonal contrast is the most important element that assists persons with visual impairments to distinguish between two different surfaces. A minimum difference of 26 points in the Light Reflectance Value of colours of two architectural surfaces produces an adequate luminosity contrast that is perceivable by people with visual impairments

Operable Parts

A part of a piece of equipment or appliance used to insert or withdraw objects, or to activate, deactivate, or adjust the equipment or appliance (for example coin slot, pushbutton, handle)

Public Use

Describes interior and exterior rooms or spaces that are made available to the general public. Public use may be provided at a building or facility that is privately or publicly owned

Persons with Disabilities

A Person with Disability is a person with any physical, mental, intellectual or sensory impairment which in interaction with various barriers may hinder full and effective participation in society on an equal basis with others

Ramp

An inclined way connecting one level with another; gentle ramp of 1:15 gradient is preferred as it is easier to maneuver wheelchair on gentle slope.

International Symbol of Access

The symbol is often seen where access has been improved, particularly for wheelchair users and other mobility impaired persons. The symbol denotes a barrier free environment which helps older people, parents with prams and travellers with luggage.

Tactile

That can be perceived using the sense of touch.

Tactile Guiding Pavers/ Block

These are 300mm x 300mm tiles that incorporate bars that are 5mm (\pm 0.5mm) high, 25mm wide and spaced 50mm from the centre of one bar to the centre of the next. These flat topped bars are easily detectable underfoot by people with visual impairments. They are used externally to guide people with visual impairments along the circulation path. They may also be used internally in large busy areas.

Tactile Warning Pavers/Block

In order to warn persons with visual impairments of the approaching danger, it is recommended to incorporate Tactile Ground Surface Indicators (TGSIs) along the approach path to avoid obstacles and hazards. TGSIs, also commonly known as ‘Tactile Warning Blocks’, are 300mm x 300mm tiles that incorporate rows of 5 mm (± 0.5 mm) high flat-topped blister like domes that are easily detectable underfoot by persons with visual impairments. These tactile warning blocks are recognized internationally as a sign of approaching hazards, and are readily available in the domestic Indian market.

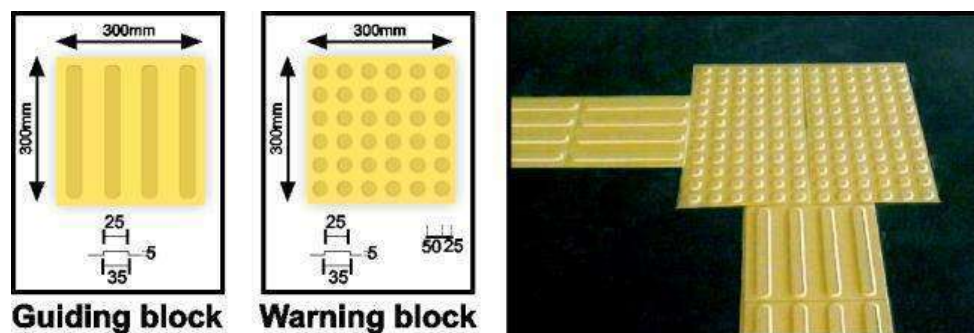

(Source Samarthyam)

1. INTRODUCTION

To create an enabling environment for social inclusion of persons with disabilities, full participation and equity, so that they can realize their aspirations; it is mandatory that we create and provide a sustainable built environment which is accessible for all.

Although there is identified need by several service providers and stakeholders, however, there is no Guidelines with updated national accessibility standards and user-friendly designs available till date. For planning, retrofitting and maintenance of sports complex, stadiums and residential facilities for sport-persons with disabilities space standards are missing. Additionally, there is lack of knowhow on accessibility in physical infrastructure, disability specific recommendations and safety instructions resulting in barrier-filled spaces. A barrier filled environment, creates feeling of insecurity and anxiety not only in the minds of the users but also their carers.

To bridge this information gap, ‘Guidelines for Accessible Sports Complex and Residential Facilities for Sports Persons with Disabilities’ is prepared as a mandatory code of accessible standards to be implemented in entire India as per the Rights of Persons with Disabilities Act 2016. It is to ensure that infrastructure, including all facilities and services are designed with universal accessibility elements for spectators, visitors, employees, sport persons with disabilities; carers; old people; etc. The aim of these Guidelines is to make the facilities & services accessible, safe and usable by sports persons with disabilities, visitors, staff and other people visiting, using or staying in the facilities. It provides cross disability accessibility for inclusion of all sports such as blind sports, deaf sports, Special Olympics, Para-Olympics, etc.

1.1 UNIVERSAL DESIGN

“**Universal Design** is the design of products and environments to be usable by all people, to the greatest extent possible, without the need for adaptation or specialized design.”

1.2 WHY UNIVERSAL DESIGN?

Universal Design builds a society, which includes everyone and not just a few! Universal design is applicable to all information, facilities and services used by cross disability children and adults. In practice, where these standards are followed, accessibility, safety and independent usage will be enhanced for all users. It is good practice to ascertain the needs of the range of expected users as early as possible, and to check the practicality and usability of emerging designs with a diverse user panel. Designing for one group can result in solutions that address the needs of many others. For example:

- Level entry (step-free) entrances facilitate not just wheelchair users but also people with buggies; people with suitcases or shopping trolleys; people using walking or mobility aids; and people with visual difficulties.
 - Larger toilet compartments provide easier access to wheelchair users; parents with pushchairs or accompanying small children; those using walking or mobility aids; and larger-sized people.
 - Clear, well-placed signage that uses recognized symbols or pictograms helps people with reading or cognitive difficulties, and those whose first language is neither English nor Hindi.
- Sometimes one solution will not suit all and a range of options will need to be provided. For example:
- Providing both steps and a ramp where there is a change in level.

- Providing machines and equipments that offer slots at different heights to facilitate use at standing height, sitting height, and by people of small stature.

1.3 ABOUT THE GUIDELINES

The Guidelines provide accessibility standards and illustrations to ensure that the facilities and services provided are being used by all users, regardless of age, gender and disability. The Guidelines will be of use to design, construction, management and maintenance agencies; games organizing committees; sports authorities; event organizers; architects, engineers, planners, developers, designers, building contractors and workers; event organizers; NGOs, OPDs/DPOs, and persons with disabilities and families; visitors, etc.

The design solutions and standards given here attempt to minimize the barriers encountered by users with diverse disabilities and reduced mobility. It provides guidance on a universal design approach to all new buildings i.e. to include in the planning stage and retrofitting of existing environments.

The spaces standards should be applied to new and existing buildings.

The categories of public buildings covered in these Guidelines are:

○ **Stadiums/ Sports Complex**

- Sports halls should be fully accessible for cross disability persons.
- At least one shower room, one washroom and one changing room per facility should be accessible to a wheelchair user.
- Spectators' seating areas should be provided for wheelchair users.

○ **Residential buildings such as guest house, hostels and hotels**

- At least two rooms in hostel, hotel or motel, guest house or any other residential facility should be wheelchair accessible.
- Dormitories should have accessible facilities having nearest accessible bathroom as per the design standards given in this Guideline.
- Bathrooms connected to these rooms have should be fully equipped with accessibility elements. Rooms designated for wheelchair users, where possible, be placed at ground level so as to have a direct means of escape in case of fire.

Access standards and illustration given in these Guidelines are adapted from National and International Access Regulations/Guidelines such as:

- National Building Code, 2016
- Harmonised Guidelines and Space Standards for Persons with Disabilities and Elderly, 2016
- IRC 103: 2012, Guidelines for Pedestrian Facilities, Indian Roads Congress
- Model Building Bye-Laws, Ministry of Housing & Urban Affairs, Government of India
- Promotion of Non-Handicapping Physical Environments for Disabled Persons Guidelines, United Nations Economic and Social Commission for Asia and the Pacific (ESCAP), 1995

The Guidelines covers structural needs and finishes which needs to be provided while planning, designing and retrofitting buildings. **It also highlights access to information, communication, technological, websites and online booking processes, and facilities & services.**

■ **Structural Needs**

- Approach,
- Parking,
- Main Entrance,
- Reception & Enquiry Counter,
- Corridors,
- Vertical Circulation,
- Elevator,
- Stairs,
- Ramp,
- Handrails,
- Toilets,
- Changing rooms,
- Spectator Seating Area (Indoor & Outdoor) and
- Emergency Evacuation

■ Finishes

- Exterior and Interior,
- Doors with Hardware,
- Floor Finishes,
- Signage,
- Lighting,
- Colour and Luminance and
- Contrast

2. Approach

- The sports and training building shall be accessible from public transport system and should be in close proximity of the main road. Approach roads should be regularly maintained and should have firm and even surface, with a finish which is slip resistant in all weather conditions.
- The width of paths should be appropriate to meet the needs of all users. A recommended clear width of 1800mm will allow two wheelchair users to pass each other on path, however where obstacles are unavoidable and 1800mm width cannot be provided, a clear width of at least 1200mm should be provided throughout the path.
- An access route should be provided connecting all major entrances & exits of the building from the alighting and boarding point of taxi stands and car park lots for persons with disabilities.
- The building should have all accessible entrance doors complying with (Section 11).
- In multi storey buildings, the accessible entrance must have an accessible route leading to the elevators.
- The accessible entrance, if different from the main entrance, should be located adjacent to the main entrance and not at the rear of the building. The accessible entrance should be clearly signed and easy to locate.
- Symbol should be displayed at all other non-accessible entrances to direct persons with disabilities to the accessible entrance.
- A clear, firm and level landing of at least 1800mm x 1800mm should be provided on either side of the entrance door.
- Any kerbs in the route should have appropriate drop kerbs (kerb ramps) to allow access to a wheelchair/walker user (Photo 2-1).

Key accessibility issues	Example
<p>Equitable approach to a building, e.g. designed parking, clear pedestrian routes separate from vehicles and cyclists, no steps or obstacles, short distances from parking and public transport, good signage, good lighting and good contrast.</p>	

Photo 2-1. Step less entry with Designated Accessible Parking



Photo 2-2. Clear and leveled approach with Kerb Ramps

3. Accessible Parking

- Accessible parking of size 3600mm x 5000mm inclusive of aisle space of 1200mm should be provided within 30 meters of the accessible entrance of the building. This parking lot can be used by tricycle users, adapted scooters users and four wheelers.
- On the route from the entrance to the accessible parking spaces, signs should indicate the whereabouts of accessible parking by the international symbol of accessibility, to guide users.
- These signs should be positioned at 2000mm height, so that they can be seen even if cars are parked in the vicinity, and shall be 600mm x 600mm size, to be identified from the driver's seat.
- All security guards/staff should be sensitized and well informed about these reserved parking for persons with disabilities.

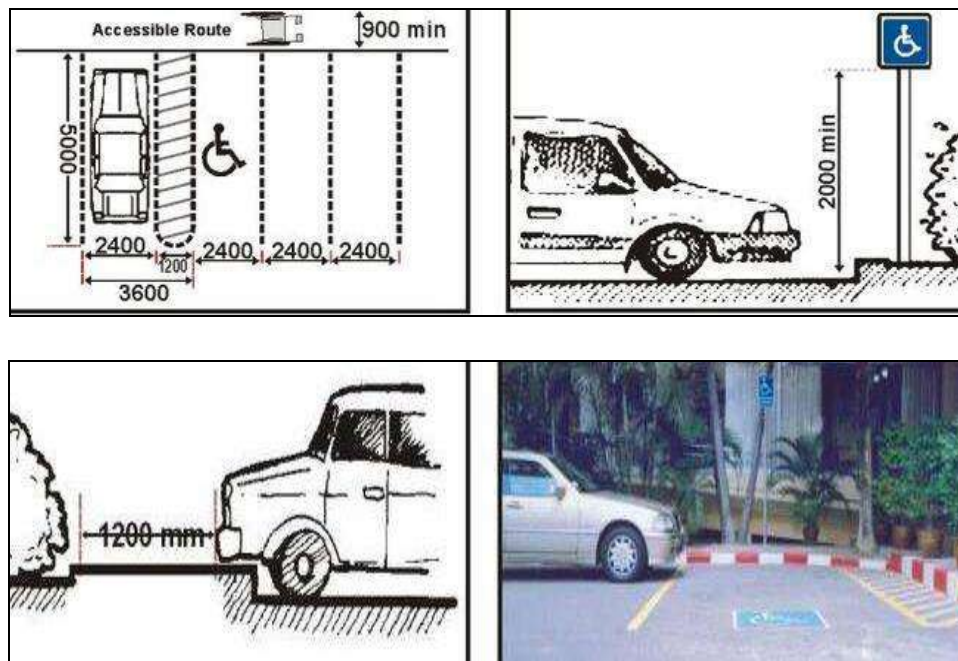

Figure 3-1. Accessible parking standards



Figure 3-2. Signage for accessible parking

Total number of parking spaces in open car parks or car park buildings:	Minimum Number
1 to 25	1
26 to 50	2
51 to 75	3
76 to 100	4
101 to 150	5

Table 3-1 Required minimum number of accessible spaces in accessible parking

4. Main Entrance

- Entrance should be easy to locate and adequately signposted (Photo 4-1.).
- Avoid thresholds; if unavoidable, they should be no higher than 6mm.
- Doors should be easily identifiable and contrast visually with the surrounding wall (Photo 4-2.).
- The floor texture in front of the door should be different from the surrounding floor texture. A thin foot mat or tactile warning paver also helps in providing textural change in flooring.
- There should be landing of 1800mm x 1800mm immediately next to the door.
- Where glass doors are used they should have color strips or other markers at 1000mm and 1400mm height.
- Entrance/ exits where revolving doors are provided, an adjacent alternate accessible entrance should be provided.
- For door and door hardware, refer Section 11 and 12.



Photo 4-1. Accessible Main Entrance with Tactile Pavers



Photo 4-2. Colour Contrast and Signage for Activity Rooms
(Photos Courtesy: Joseph Kwan)

5. Signage

Effective way finding and signage is required at all public places to provide information and indicate the direction to reach a particular destination. These are essential for visitors at hospitals, health centres, schools, colleges, public buildings and on the streets and the highways. Signage guide and enable the person to reach a given destination on time without any mishaps.

Signage benefits everyone. It also enables people with visual, speech & hearing impairments and people with intellectual and learning impairments to use the environment, as independently as possible. When provided at strategic locations, it reduces the effort required in way finding.

- **External:** should be mounted above 2200mm from the finished floor level for proper head clearance.
- **Internal:** should be placed between 1400mm to 1600mm from the finished floor level on the wall. **International Symbol of Accessibility:** to be displayed for all the accessible services and facilities provided.

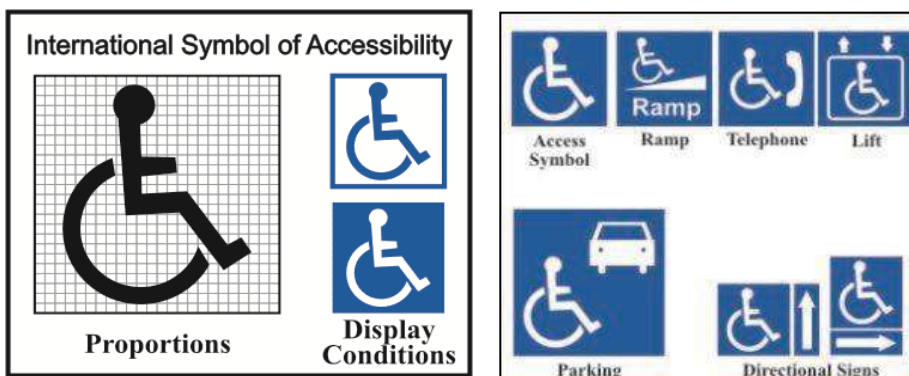

Figure 5-1. International Symbol of Accessibility

(Source: Samarthyam)

- **Sign board:** should also contrast with the wall on which it is mounted.
 - Surface of the sign should not be reflective.
 - Some signs such as those adjacent to or on a toilet door may be embossed so that they can be read by touch.

- Illuminated signs should not use red text on a dark background.
- Signs should be supplemented by Braille.
- Large print, good colour contrast between text / symbols and their background should be provided.
- Sans serif fonts such as Arial, Helvetica, Lucida Sans, Verdana etc. should be used.
- Use bright coloured symbols/ pictograms to denote or mark different places like living room, store room, kitchen, toilet, common rooms, therapy room, etc.
- Clear indications of eating, sleeping, recreational, work areas will enable individuals to function, work and live better.
- Real objects as pictograms can be used for signage; for example a tap with a tumbler for the drinking water area or a bed for bedroom (Figure 5.2).



Figure 5-2. Pictograms

- For a multistoried building, key plans of all the floors to be placed near the main entrance/reception area and in the lift and staircase.
- An illustration with different colours to be given in the key plan to help interpret the signage on each level. For example: red colour for first floor in the key plan and red colour signage at the staircase and/or lift entrance helps in identification of the floor.
- Signage incorporating graphic symbols is easier to understand than purely text-based signage.

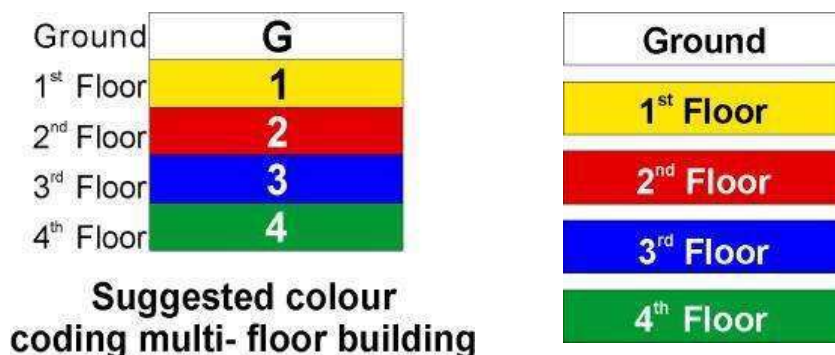

Figure 5-3. Colour coding example in a multi storey building

5.1 IDENTIFICATION SIGNS

- **Orientation and Way-finding Signs:** These signs include way-finding maps and directories. It should include a list of departments, offices, organizations, room numbers and general building facilities locations. Interior building directories should be planned in the early stages of building construction to fit into the overall design scheme. It may include a tactile map with audio.
- **Building Directory Signage:** Buildings having multiple activities / games/ events etc., the departmental identification and listings should be noted on directories within the building or on directory signs serving visitors areas adjacent to the facility (Photo 5-1).



Photo 5-1. Multiple consistent directory signs at every major decision point

(Photo Courtesy: Joseph Kwan)

- **Destination Signs:** These signs identify places, resources, specific functions within the building. They include symbols and/or words, as required. The text is usually brief, generally one to four words, naming the room where the sign is located, e.g., Staircase, Director's Room, etc. Secondary signage is located in circulation areas that identify facilities and services, e.g. Photocopier, Payment Counter, etc.
- **Room Number/ Identification Information Sign:** The sign should consist of 1-1.5mm raised and 25mm high numbers/letters with contrasting colour background. Information in Braille to be provided directly below numbers. Maintenance rooms, utility closets need not have identification information; room number is sufficient. Room number to be placed on walls adjacent to room doors on the latch side. It should be placed on walls adjacent to room doors on the latch side, 50mm away from door frame, 1400mm-1600mm from floor, provided towards latch side of the door (Figure 5-4).

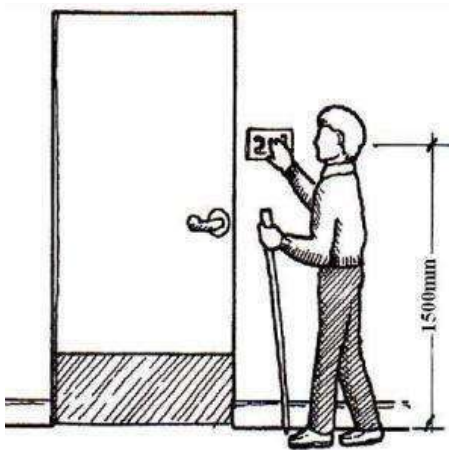

Figure 5-4. Placement of Braille Signage



Photo 5-2. Room information in Braille, embossed and colour contrast

- **Accessible Toilet Signage:** Toilet sign should consist of a plate/ board with 1mm raised white characters, 25mm high and 6mm border on a Navy Blue background. The International Symbol of Accessibility must appear on all bathrooms and changing rooms that are accessible. It can also have a room number sign if required. Braille must be located directly below lettering. Only text and Braille have to be raised, pictograms do not have to be raised (refer Figure 5-5).

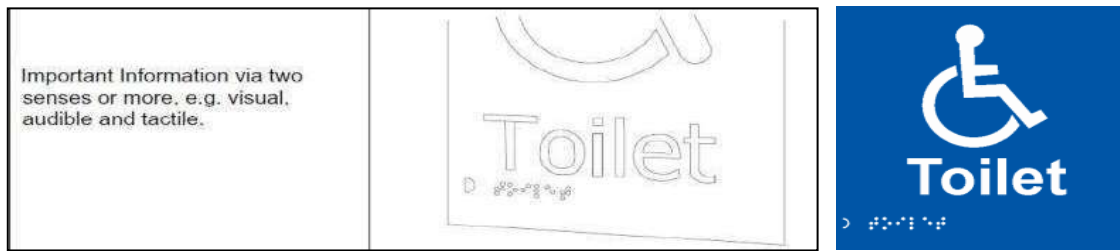

Figure 5.5 Accessible Toilet Signage

- **General Toilet Signage:** General toilet signage should have pictogram (male in triangle and female in circle), marked on plates 7.5mm thick, along with Braille & raised alphabets for the benefit of the persons with visual impairment. To be placed on walls adjacent to room doors on the latch side, 50mm from door frame, 1400mm above the floor.

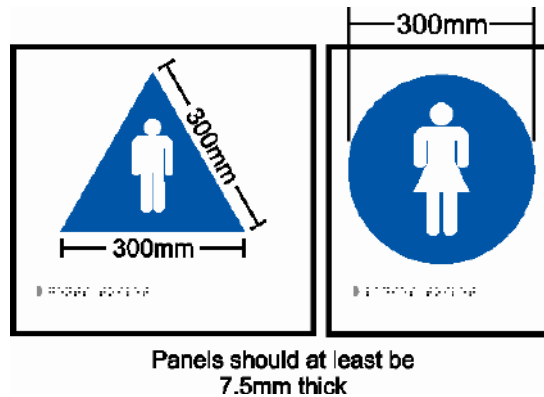

Figure 5-6. General Toilet Signage

- **Elevator/ Stairs:** These signs should consist of a plate/ board with 1mm raised white characters, 25mm high and 6mm border on a contrasting background. Pictogram height should be a minimum of 150mm. Only text and Braille have to be raised, pictograms do not have to be raised.



Figure 5-7. Sign for Lift

- A staircase sign should also be located in the stairwell itself, preferably at the landing, to tell the person the floor they are on.



Figure 5-8 Sign for Stairs

5.2 DIRECTIONAL SIGNS

These signs guide people to areas or services within the building. They facilitate movement directing one towards specific rooms and facilities. They should be located along corridors, elevator lobbies, entrances, or staircases. They usually use an arrow and will utilize other symbols whenever possible. Information on the sign is grouped by direction.

- **Ceiling Mounted Directional Sign:** The ceiling mounted directional sign should consist of minimum 100mm wide sections. A large, distinct bold arrow should indicate direction of places listed, either in a group or individually. This sign can be single or double-faced with colour contrast. Text should be a minimum 75mm height for a sign mounted at a 2050mm height.



Photo 5-3. Ceiling Hung Directional Sign

5.3 REGULATORY SIGNS

These are required to inform of certain restrictions or alert people to lifesaving devices or areas in buildings. Symbols may be used and communication is made in positive terms whenever possible.

They should be located in general areas, e.g., Emergency Exit, Fire Alarm, No Smoking, First Aid. They may also include secondary signs for specific users, locations, e.g., Keep out of Enclosed Areas, Turn off Computer after Use.

- **Evacuation Plan:** This sign is installed on corridor walls at strategic locations, and in each large gathering space, e.g. Lobby, conference hall, auditorium, etc. It includes a floor plan with “YOU ARE HERE” Message. The signage shall have a simplified floor plan that shows the locations of and directions to the fire exits and a refuge area.
- **Fire Exit Door:** This signage should consist of a 125mm x 125mm red plate/ board 1mm raised white letters. Braille must be located directly below lettering.



Figure 5-9. Emergency Signs

5.4 TEMPORARY SIGNS

Provisions must be made for temporary signs that are required for a limited period. They should follow the overall signage scheme. These include notices on Bulletin boards, Event posters and Free-standing Signs, e.g. Announcements, Holiday Notices, etc.



Photo 5-4. Temporary Signs

6. Reception/Equity counter

- **Reception:** Location of the reception should be such that it is easily identifiable from the entrance. The approach to the reception should be obstacle free.
- The reception should be designed, so as to accommodate both standing and sitting guests. The standing section should range from 950mm to 1000mm in height. Height of seating section should be 740-800mm and there should be leg and knee space to accommodate wheelchair users. This can be achieved by providing a seated section that is minimally 760mm high x 1500mm wide x 700mm deep with a 700mm high knee recess. A minimum clear floor area of 1200mm depth and 1800 mm width is required in front of any reception desk or counter to enable sufficient maneuvering space for wheelchair users. The face of the receptionist should be evenly lit.
- There should be a hearing enhancement system such as a **loop induction unit**, the availability of which is clearly indicated with a symbol at the reception/ counter.
- **Sitting Benches:** All benches must have a minimum depth of 450mm (ideally 500mm) and be set at a height of 480mm to allow easy transfer from a wheelchair. These should have a smooth finish to surfaces and no sharp edges.
- **Color Contrast:** There should be adequate colour and tonal contrast between fittings, walls, ceilings, floors and so on to assist persons with visual impairments. The surface of the reception counter should be non-reflective.
- **Single Window Facility:** This helps in quick facilitation of persons with disabilities and senior citizen who do not have to wait in long queues. This counter/ window should be provided nearest to the entry and signage for the same should be displayed at strategic locations.

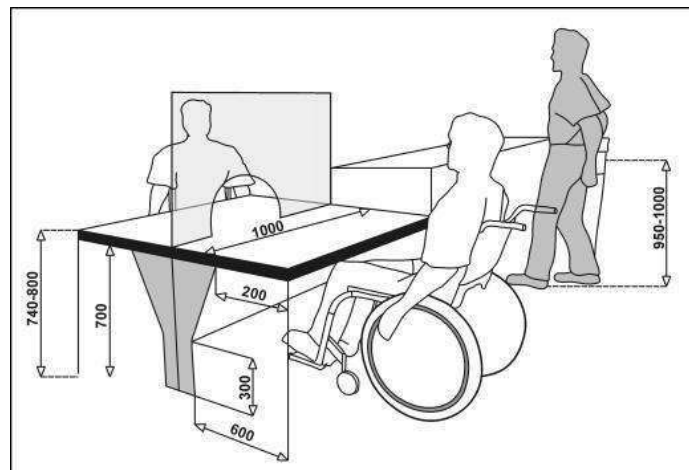

Figure 6-1. Counters at two levels



Photo 6-1. Reception with adequate illumination, two levels and colour contrast

7. Ramp

The provision of an internal ramp benefits many people, including anyone pushing a trolley, buggy or stroller; people using a wheelchair; and those conversing in sign language while walking. Ramps also aid independent and assisted evacuation in many instances, such as when lifts are unavailable. People are generally much less likely to trip on a ramp than on stairs. People also tend to feel more confident assisting another person on a ramp than on stairs.

Ramp with a gradient of 1:12 is found steep by many wheelchair users, while using it independently. Wheelchair users roll backwards on such steep ramps while ascending and lose control during descending which might result in accidental hazards.

- **Gradient:** 1:15 maximum.
- **Width:** 1500mm minimum; 1800mm is preferred.
- **Landings:** 1500mm x 1500mm minimum at the beginning and the end of the ramp. At turnings at intervals of every 5 metres for a gradient of 1:12 and every 9 metres for a gradient of 1:15 or 1:20.
- **Handrails** to be on both sides at a height of 760mm-900mm, painted in contrast colour against the background wall.
- **Warning tactile paver:** should be placed at 300mm before and after the ramp edges.
- **Surfaces (ramp & landing):** should be slip resistant. Grooves on cement ramp not exceeding 5mm or checkered tiles can be provided.

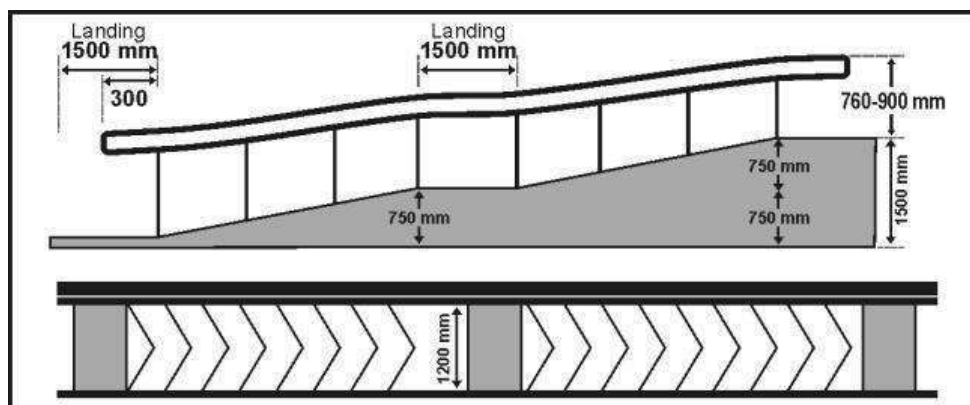

Figure 7-1. Ramp with 1:15 slope, 1200mm width and horizontal landings at beginning and end

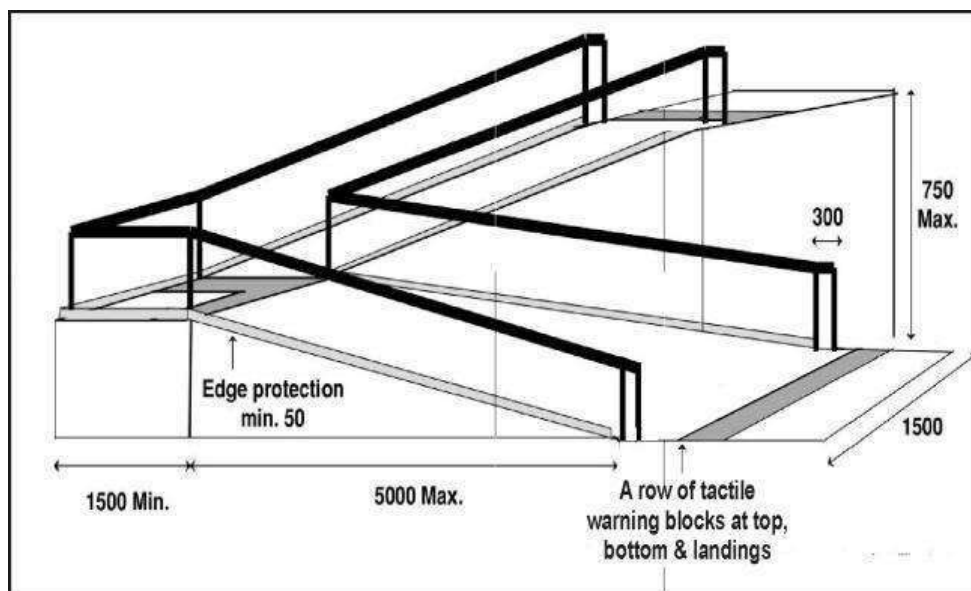

Figure 7-2. L-shape Ramp with 1:15 slope, 1500mm width and horizontal landings at beginning and end

- Illumination level between 100-150 lux should be maintained on the ramp.
- Material selected for the surface finish of a ramp should be firm and easy to maintain. It must also be slip resistant, especially when wet.
- There need to be warning blocks at the beginning and end of each ramp in the external environment. The warning blocks are to be laid at a setback of 300mm – 600mm before the beginning and at the end of the ramp.
- The space under the ramp to be cordoned of either by putting handrails or building a wall in front of it. This space can also be used as storage area if required.
- Buildings where there are space constraints, turning platform or switch back (dog leg) ramps can be provided.

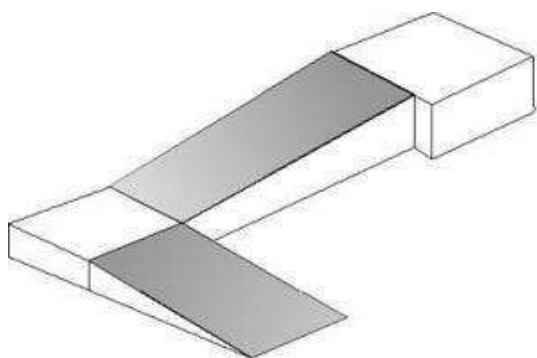

Figure 7-3. Turning Platform (L-shape) Ramp

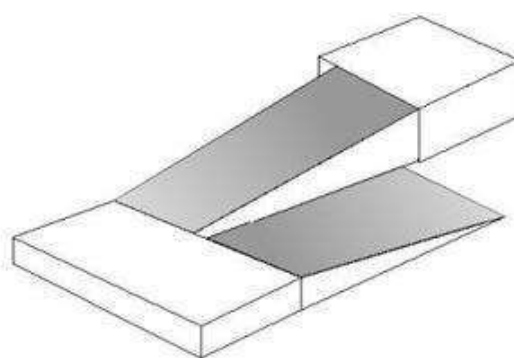

Figure 7-4. Switch Back Ramp



Photo 7.1 Combination of ramp and steps

CHECKLIST

•	Ramps should ideally not be steeper than 1:15.
•	Steps should always accompany a ramp and vice-versa.
•	Circular handrails should be installed at a height of 900mm from the ramp surface on both sides of the ramp and fixed with L-shaped brackets.
•	Ramps should at least be 1500mm wide, and have landings every 5 meters run and at the top and bottom of the ramp.
•	Ramp surface should be slip resistant. Provide uniform illumination level between 100-150lux on the ramp surface.
•	Tactile warning blocks should be installed at the beginning and end of the ramp.

8. STEPS AND STAIRCASE

Stairs should be safe and easy for everyone to use. They should be clearly visible and easy to identify. Spiral stairs and stairs with tapered treads should not be used, as they are much more likely to cause tripping. The dimensions of each step should be consistent throughout a stair flight.

- **Uniform risers (step height):** 150mm maximum.
- **Uniform tread (step width):** 300mm minimum.
- **Nosing:** steps without projecting nosing are preferred; but if a projection is required, the riser face should be chamfered to an angle of at least 60 degrees and the overlap limited to 10mm.

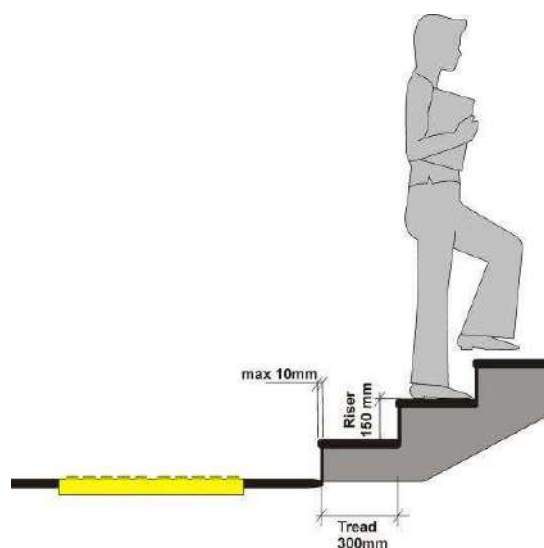

Figure 8-1. Step Riser and Tread

- The steps should have an unobstructed width of at least 1200mm.
- Step edges should have bright contrasting colours: 50mm minimum to easily identify depth and width of steps.
- Landing should be 1200mm deep, clear of any obstruction.
- Steps and staircases should have handrails on both the sides. In absence of handrails persons with mobility impairments, find it extremely difficult to climb steps. Continuous handrails on both sides, including the wall (if any) and also on landings should be provided.
- Handrail should be at two levels 900mm and 760mm, painted in contrast colour to background wall.
- Warning paver to be provided 300mm before the beginning and at the end of all set of steps and at landings.
- 50mm wide contrast colour band/strip should be provided at the step edge, extending the full width of the step. Paint or tapes can be used to create the contrast. Some companies provide anti-skid tapes that can be used in contrast colours on step edges.
- Should be adequately and uniformly illuminated with level of illumination between 100-150 lux minimum.

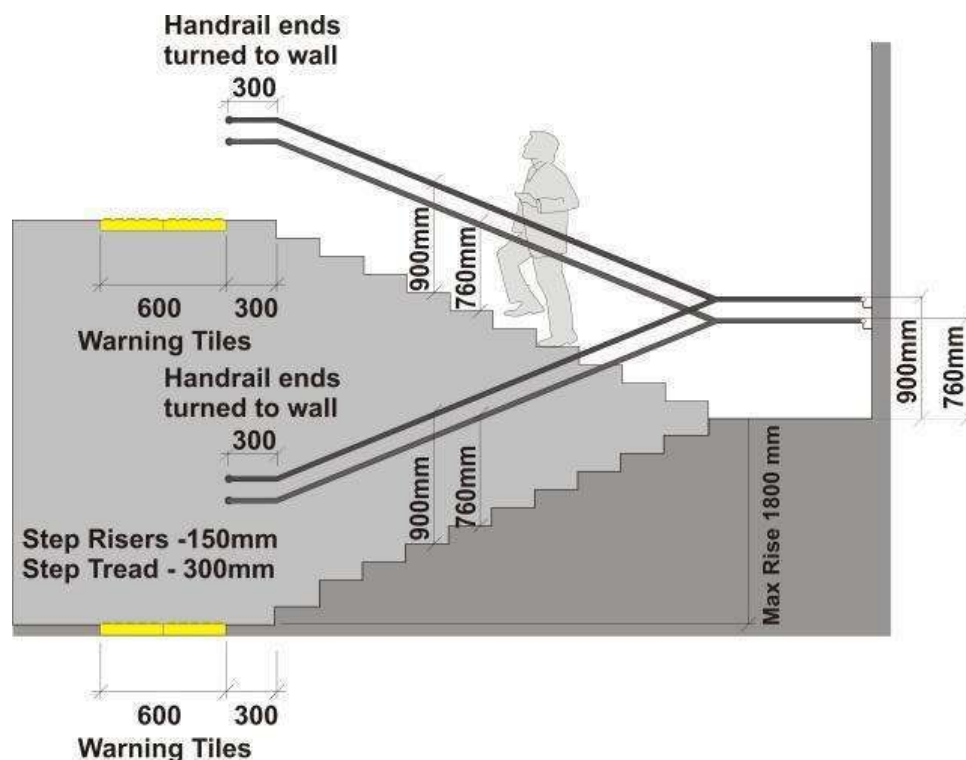

Figure 8-2. Placement of handrails and tactile warning pavers



Photo 8-1. Accessible elements with colour contrast interiors

(Photo Courtesy: Joseph Kwan)

CHECKLIST

•	Make sure each step edge is visually highlighted.
•	Clear width of steps not less than 1200mm.
•	Check that total rise of flight between landings no more than 1800mm or 12 steps.
•	Install consistent number of steps in consecutive flights.
•	Avoid single step on access route.
•	Provide clear landings on top and bottom of steps.
•	Use warning tactile pavers at top and bottom of flight.
•	Provide handrails on both sides of steps and continuous around intermediate landings.
•	Provide an additional central handrail where the stairs are more than 2000mm wide.
•	Cordon off any area below stairs that has headroom less than 2200mm.
•	Illuminate step and landing surfaces - level between 100-150 lux.

9. HANDRAILS

Handrails should be provided on both the sides of steps and ramps and should be continuous, even at the landings.

- **Diameter:** Should be circular in section with a diameter of 38-40mm (Figure 9-1).
- **Height:** at two levels 760mm and 900mm from the floor level.
- **Knuckle space:** have at least 50mm clear space from the surface to which they are attached.
- **Extension:** at least 300mm beyond the steps and ramp.
- **Ends:** to be either grouted in the ground or wall or rounded off.
- **Material:** should contrast with the wall finish (or use dark tiles behind light coloured rails) and provide good grip.
- **Multistoried building:** provide tactile features indicating the floor level on the handrail/ end of the rail to persons with visual impairments (e.g. indicate the floor level on each handrail by use of raised dots, where one dot indicates first floor, two dots indicate second floor, and so on) (Photo 9-1).

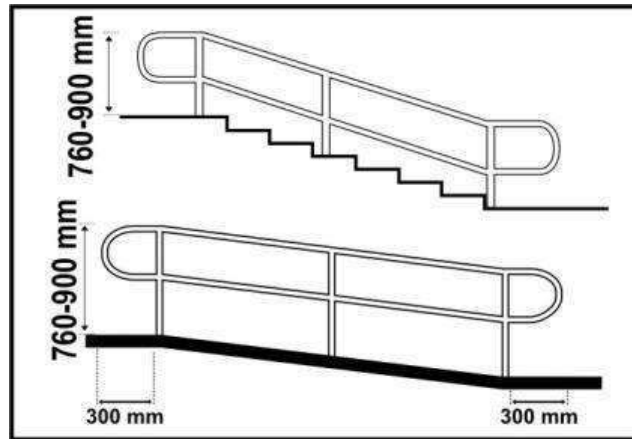
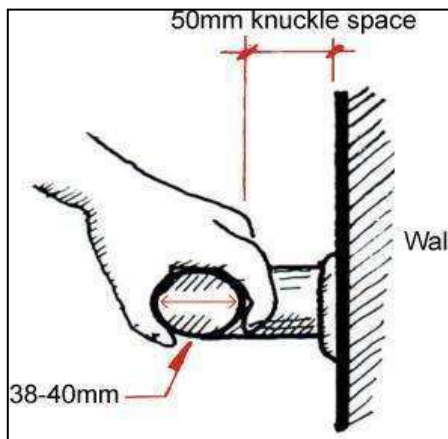

Figure 9-1. Handrail diameter

Figure 9-2. Placement of Handrails on Ramp and Steps

(Adapted from UNESCAP Guidelines)



Photo 9-1. Handrail with Braille Information

(Photo Courtesy: Joseph Kwan)

10. Lift

Lift should be provided in a multi-storied building to provide access to all floors and make these usable by persons with disabilities.

Lifts should have international symbol of accessibility and directional signs indicating the way to lift (Figure 10-1).

- **Colour:** lift door and panel should be in bright colour contrast, instead of glazed steel or any other metallic shade that produces glare.
- **Car space:** Internal floor space 1500mm x 1500mm minimum.
- **Doors:** 900mm wide and closing mechanism to be adjusted to give adequate entry time. Alternatively sensors should be installed.
- **Call button:** at a reach of 800mm-1000mm; at least 450mm from any corner or wall to reach the call button.
- **Control panel:** inside the lift preferably on both the sides, having buttons with Braille and also raised letters and in bright contrast from the background.
- **Audio announcement:** for door opening/closing and floor levels.
- **Key plan:** of all floors to be placed inside the lift.
- **Vision panels:** should be provided on the lift door at two levels-800mm & 1500mm.
- **Level difference:** gap in level between the lift car and the outside floor surface should not be more than 10mm.
- **Floor directory:** of the main facilities and services available on the lift landing, along with an accessible emergency egress route that clearly indicates the location of nearest refuge areas for persons with disabilities.

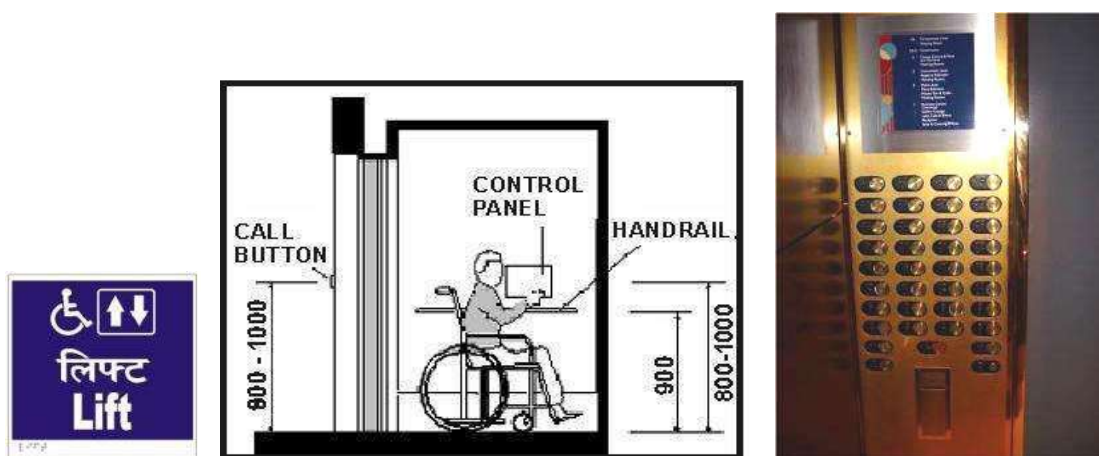

Figure 10-1. Lift Signage, Internal Dimensions and Control Panel

Photo 10-1. Control panel
(Photo Courtesy: Joseph Kwan)

- **Internal finish:** The use of visually and acoustically reflective wall surfaces should be minimized within the lift car as visual reflections can cause discomfort and affect the visual acuity of people with visual impairments.
- **Flooring:** of the lift car should be slip resistant and have similar frictional qualities to the floor of the lift landing to decrease the risk of stumbling.
- **Mirror:** on the wall of the lift car opposite the lift door allows the wheelchair user to see if anyone is behind them and also to see the floor indicator panel. The mirror should be kept above 900mm from the lift floor to avoid confusing people with visual impairments.
- **Emergency communication system:** should be coupled with an Induction Loop system installed all around the lift.
- **Telephone units:** should have an inbuilt inductive coupler to assist persons using hearing aids.



Photo 10-1. Lift signage and colour contrasted amenities

(Photo Courtesy: Joseph Kwan)

11. DOORS

- **Clear opening:** 900mm minimum (space between door frame and door opening and not between frame to frame).
- Be fitted with **vision panels** at least between 800mm and 1500mm from floor level. In emergencies, vision panel may be removed/ forced to open the locked doors.
- Be **color contrasted** with the surrounding wall and should not be heavier than 22N to open.
- **Room doors:** should open inwards and not towards the corridors /general circulation area.
- **Accessible toilet doors:** should open outwards or slide to provide internal space for helping individual in emergency situation.

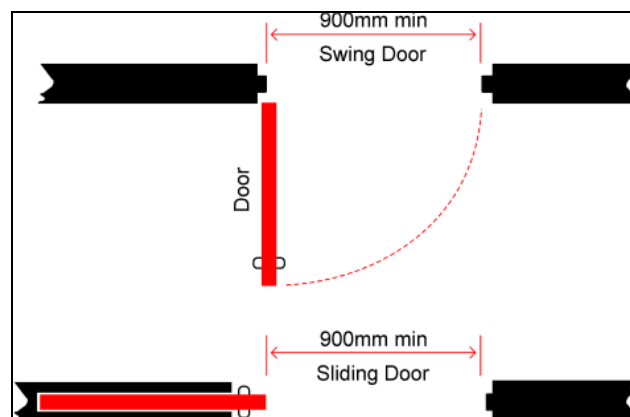

Figure 11-1. Sliding and Swing Door

(Adapted from UNESCAP Guidelines)



Photo 11-1. Room Signage in Braille

(Photo Courtesy: Joseph Kwan)

12. Door Accessories and Hardware

Door accessories and hardware should be positioned between 850-1100mm above finished floor level.

- **Operable devices:** such as handles, latches and locks should be:
 - provided between 800-1000mm
 - lever handles and push type
 - operable by one hand and do not require fine finger control, tight grasping, pinching or twisting to operate
- **Glazed/glass doors and fixed glazed areas:** should be made visible by use of colour and tone contrasted warning or decorative feature that is effective from both inside and outside. These should be visible under any lighting conditions, e.g. a logo of minimum dimensions 150mm by 150mm, set at eye level, can be provided.
- **Foot mats:** either recessed in the ground or thin rubber mats to be provided, for persons with visual impairment to easily detect all entrances.
- **Kick plates:** (aluminum/rubber) at 300-400mm of height from the floor level to be provided on the doors (to avoid wear and tear).

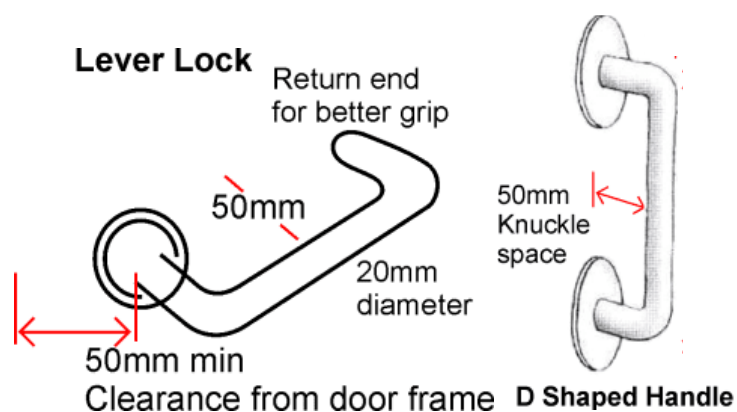

Figure 12-1 Knuckle space and height of D-shape handle

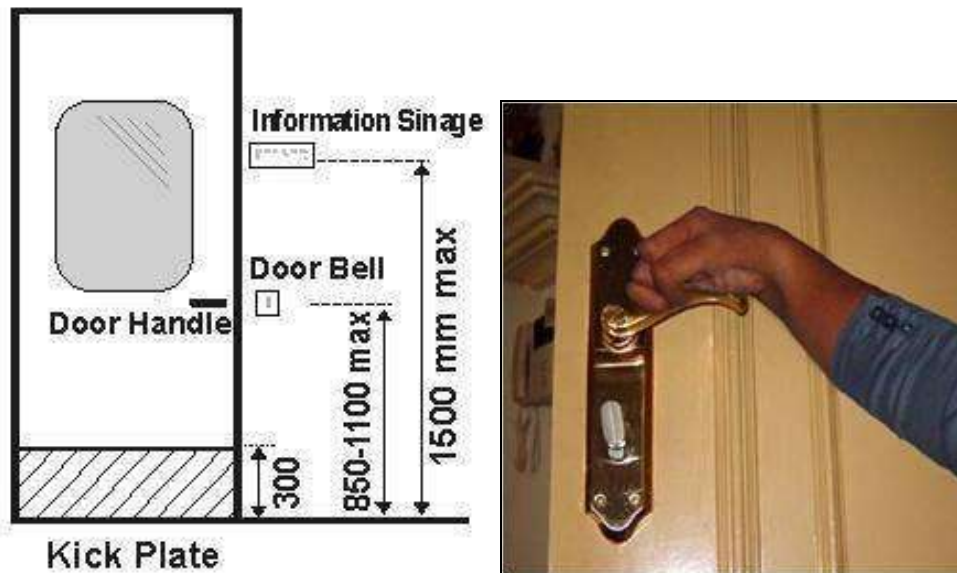

Figure 12-2. Door hardware
(Adapted from UNESCAP Guidelines)

Photo 12-1. Lever Handle is friendly to use
(Photo Courtesy: Judy Wee)

13. Corridors

Corridors should allow easy movement and provide a sense of direction in the circulation routes. There should be colour contrast between the floor and the wall and also between the wall and the ceiling which helps persons with visual impairments.

- **Corridors:** should have an unobstructed width of 1500-1800mm and to be uniformly well lit. One thick strip of florescent/bright colour (orange/yellow) on floor may be provided to give better orientation.
- **Threshold (door sill):** at the entrances and level differences more than 6mm, should be beveled i.e. provide slope on both side of vertical height.
- **Obstacles and protruding objects:** more than 100mm from the wall, such as cluttered furniture, almirahs, telephone, fire extinguishers, benches, flower pots and decorative fixtures should not be placed in the corridors.
- **Width:** be wide enough to allow easy access of people cases, parents with prams and people on crutches to pass each other on route. The minimum width of the corridor should be 1500mm with wheelchair turning spaces of 1800mm x 1800mm at regular intervals.
- **Circulation routes:** that allows easy movement and provides a sense of direction.
- **Doors:** are potential barriers, it is recommended not to use them in corridors, but wherever used doorways should be used without a self closing device. When closing device is needed such as in fire doors, it should be electrically powered so that the closing device is activated only in case of emergency.

13.1 FLOOR FINISHES

- Glazed tiles/marble (being very slippery) as flooring material should be avoided. Matt finish tiles/ PVC strip/any other anti-skid material should be used, to prevent persons using mobility aids from slipping. It also provides tactile indication to persons with visual impairments and helps to indicate earmarked spaces for different activities.
- Flooring to be of uniform shade and not mosaic pieces, which are confusing to many.
- To aid people with visual impairments, there should be good color contrast between the floor and the wall and also between the wall and the ceiling.
- Lighting requirement in a corridor is 100 lux minimum.
- It is also important that the corridor is acoustically well designed, to avoid excessive reverberation or too much absorption of sound.



Photo 13-1. Floor finishes and visual contrast in corridor (Photo Courtesy: Joseph Kwan)

14. Switchboards

Switchboards should be outlined in contrasting color for persons with low vision, to be able to identify from the wall. Vinyl tapes/Acrylic paint (yellow/black/red) can be used for the same.

- To be within the reach of wheel chair users and persons with short stature i.e. should be mounted between 400mm-1100mm from the finished floor level.
- All the electric socket should be with a safety shutter, which ensures child safety feature
- Switches to have a tactile marking, such as: a raised symbol of fan for the fan switch and bulb symbol for the light.

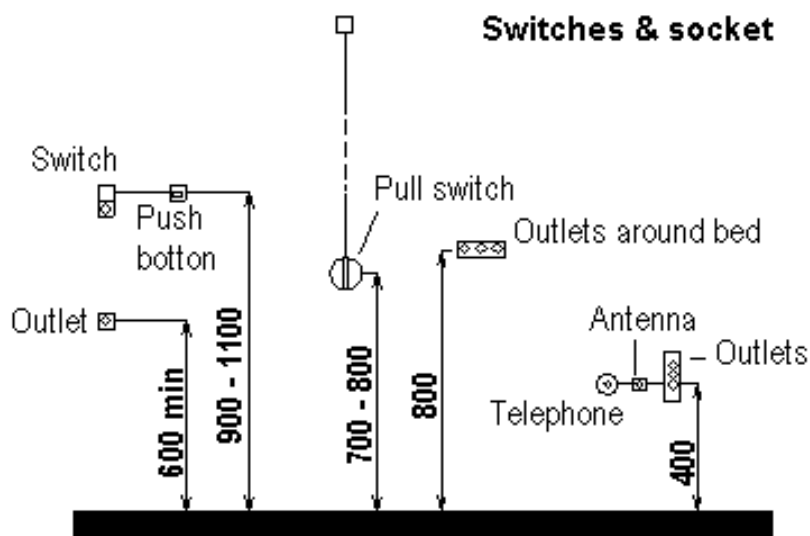

Figure 14-1. Switches and Alarms in Bedroom

(Adapted from UNESCAP Guidelines)

14.1 ILLUMINATION

- All activity/ internal areas to be well lit (250-300 lux), sufficiently bright and positioned to facilitate reading and other activities.
- The lighting requirement in a corridor and staircase is 100 lux minimum.
- Light fixtures CFL/LED lights with appropriate shades focusing down are recommended.
- Do not use naked bulbs!



Photo 14-1. Ramp adequately illuminated with natural light

15. General Toilets

- Some individuals have difficulty with commodes and others with squatting toilets (Indian seat); at least one of each kind should be provided.
- All signage of general toilets should be in bold and contrasting colors.
- For persons with visual impairments pictogram (male pictogram in triangle and female pictogram in circle), marked on plates along with Braille & raised alphabets, to be mounted on wall next to door near the latch side, at a height between 1400mm-1600mm. Refer toilet signage Figure 5-6.
- Warning tactile paver/ thin rubber foot mat to be provided 300mm before and after the toilet entrance.
- All toilet facilities should incorporate fire alarms with audio and visual systems.
- All toilets should have alarm switches (push/pull type) near the WC (one at a height of 300mm and the other at 900mm from the floor level), next to the commode, which can be activated in an emergency that triggers an audio alarm.
- Toilet seat/WC should be in contrast colour for the benefit of persons with low vision, contrast colour paint on the walls/ tiles can be used to create visual contrast.
- Urinals shall be stall-type or wall-hung, should not have any step platform. Elongated rim at 430mm above the finish floor is usable by children, short stature persons and wheelchair users.
- At least one of the urinals should have grab bars to support ambulant persons with disabilities (for example, people using mobility aids like crutches).
- Tactile warning paver to be provided for urinals and washbasins for persons with visual impairments (Photo 15-1).



Photo 15-1. Floor Markings with Warning Pavers for Persons with Visual Impairments

(Photos Courtesy: Joseph Kwan)

16. Accessible Toilet, Change Room and Bathroom

Accessible toilets & bathrooms can be used by both male and female and helps carers with opposite sex to assist persons with disabilities.



- Clear floor space 2000mm x 2200mm minimum.
- Anti-slip/ matt finish flooring.
- Clear door opening minimum 900mm, with the door swing outwards or be folding or sliding type.
- Doors should have a horizontal pull-bar, at least 600mm long, on the inside of the door, located so that it is 130mm from the hinged side of Figure 16-1. Signage the door and at a height of 900-1000mm.
- Handrails all through the toilet cubicle walls should be provided for support and balance.

16.1 WATER CLOSET (WC)

Have clear space of not less than 900mm wide, next to the water closet to facilitate side transfer.

- Centerline of the WC to be located between 460-480mm from the adjacent wall
- Seat of the WC to be 450-480mm from the floor.
- Provide movable U-shape grab bar on the transfer side and L-shape grab bar on the adjacent wall.
- If the WC is center placed i.e. the wall is more than 500mm away from the WC, movable grab bars on both sides to be provided.
- Health faucet/ hand held spray should be provided at height between 500-800mm.



Photo 16.1 Accessible Toilet

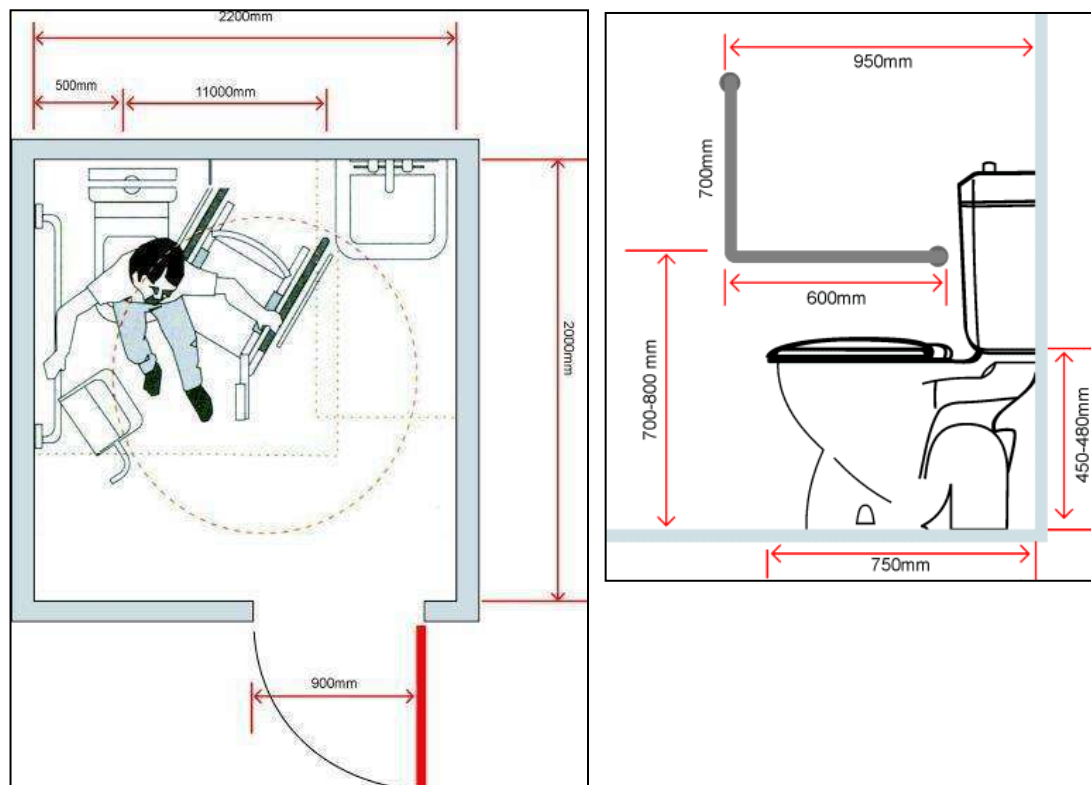

Figure 16-2. Layout of Accessible Toilet

16.2 WASHBASIN

- Be of dimensions 550mm and 410mm, so mounted that the top edge is between 700mm-800mm from the floor; have knee clearance of at least 760mm wide by 200mm deep by 650mm-680mm high.
- Lever type handles for taps are recommended.
- Mirror's bottom edge to be 1000mm from the floor and the mirror may be inclined at 25° angles to get proper image of a person in seated position.

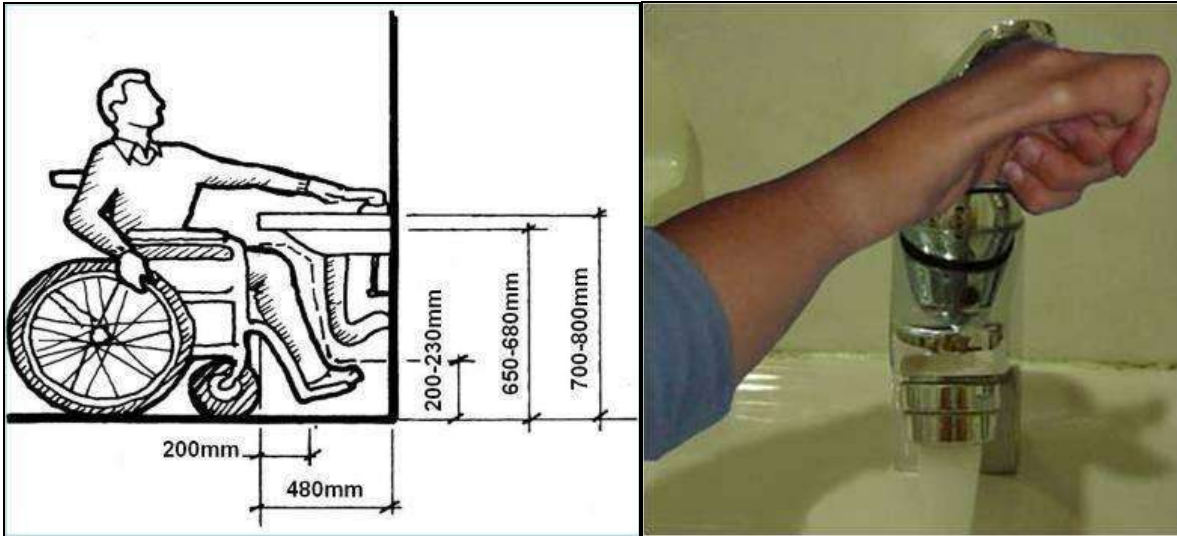

Figure 16-3. Accessible Washbasin
(Source: UNESCAP Guidelines)

Photo 16-2. Lever handle for tap
(Photo Courtesy: Judy Wee)

16.3 BATHROOM/ CHANGING ROOM

- **Shower cum toilet unit:** minimum internal dimensions should be 2300mm x 2400mm.
- **Shower unit only:** minimum internal dimensions should be 1800mm x 2350mm.

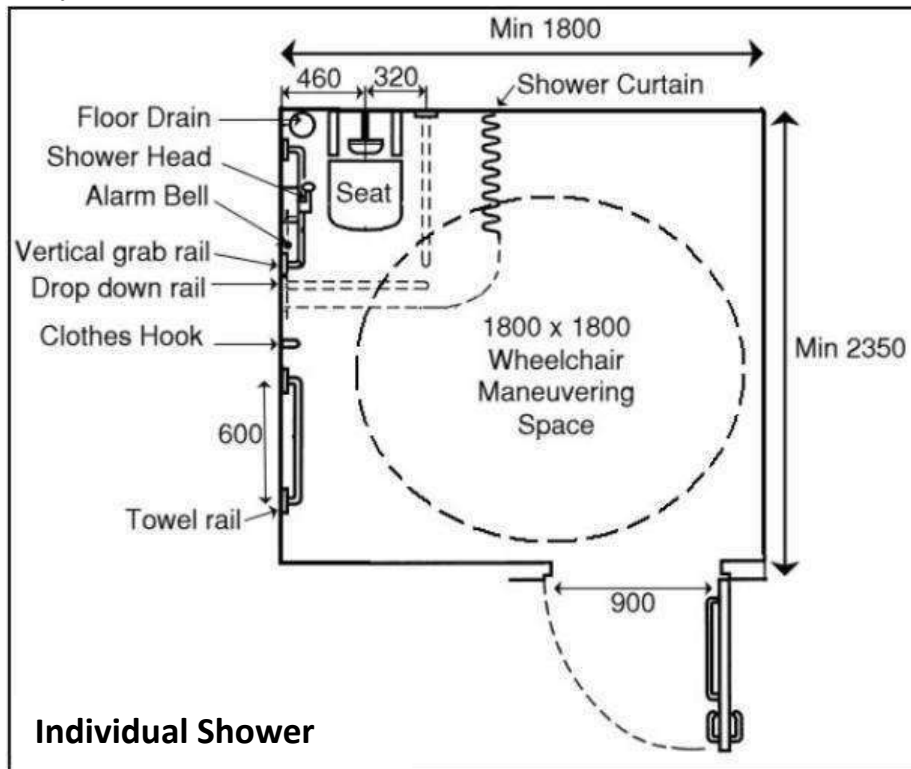

Figure 16-4. Individual Shower Unit

(Source: UNESCAP Guidelines)

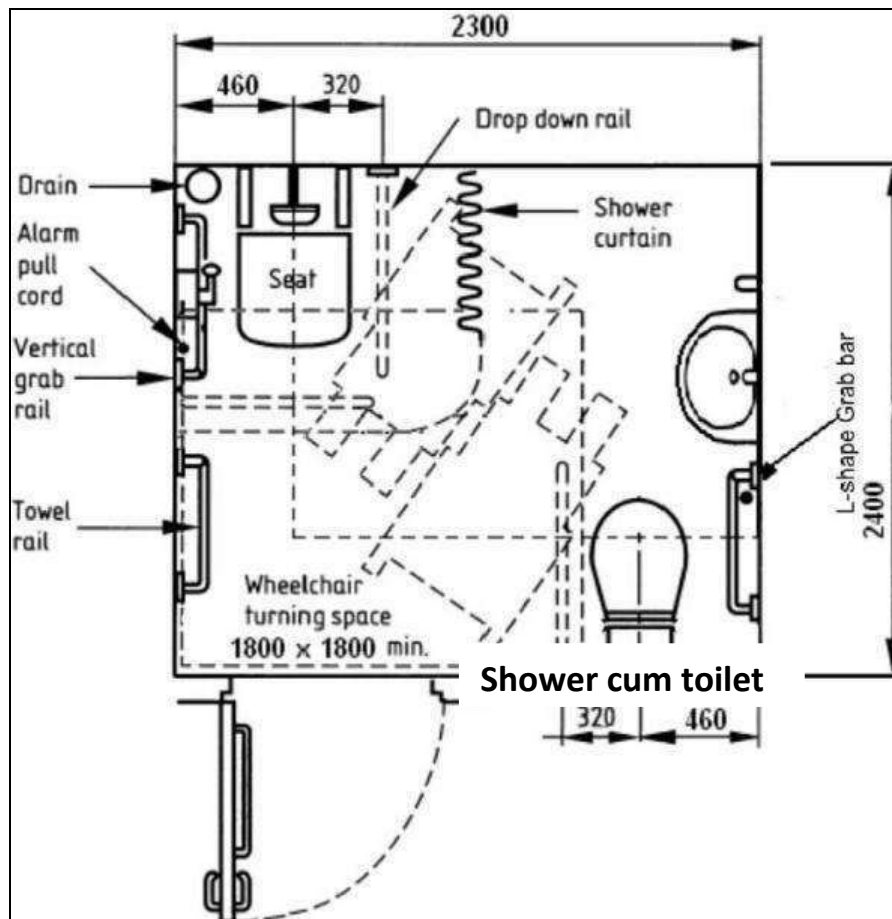

Figure 16-5. Shower cum Toilet

(Adapted from UNESCAP Guidelines)

- **Shower area:** should have a horizontal handrail for support at 800-900mm.
- **Soap shelf / tray:** at 800-1000mm height.
- **Tap:** lever type at 800-1000mm height.
- **Flexible hose (hand shower):** of 2000mm long pipe to be provided for the benefit of persons using shower seat/chair.
- **Shower spray:** should be fixed to a flexible hose and slider fitting to give an adjustable height range of 800mm - 1000mm above floor finish.
- **Shower seat:** 600mm x 600mm vertical and horizontal rails, positioned 900mm away from the shower seat. The horizontal rail should be positioned 760mm above floor finish or 200mm above the shower seat.
- Individualized adaptations, as per availability of water and usage should be made. For example, where bucket and mug are used, a small table may be provided for placing the bucket on it to be used for bathing by persons sitting on a higher level.

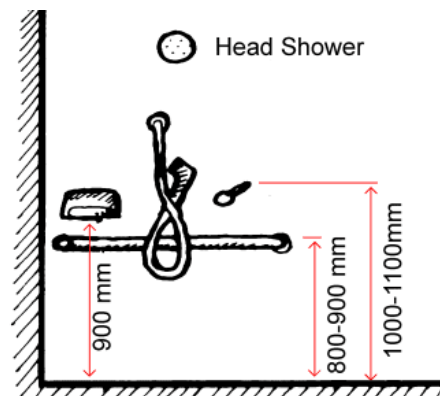

Figure 16-6. Dimension and placement of hand held (telephone) Shower



Photo 16- . Accessible changing room

16.4 SQUATTING SEAT

- In many towns and semi-urban areas, where ground mobility devices are used, people with disabilities prefer squatting toilet seats.
- Clear floor space 1200mm x 1500mm.
- Vertical grab bar should be provided, which helps in assisting a person with reduced mobility to lower into squatting position and then rise into standing again.
- Horizontal grab bar should be provided which helps in balancing and stabilizing, when reaching for water/cleaning self.
- Health faucet/ hand held spray should be provided at height between 300-400mm.

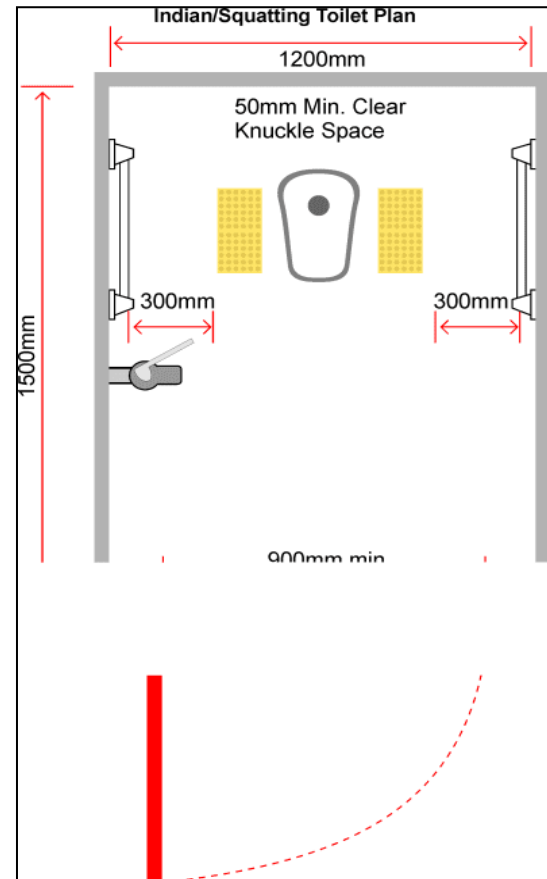

Figure 16-7. Layout and dimensions of accessible squatting seat

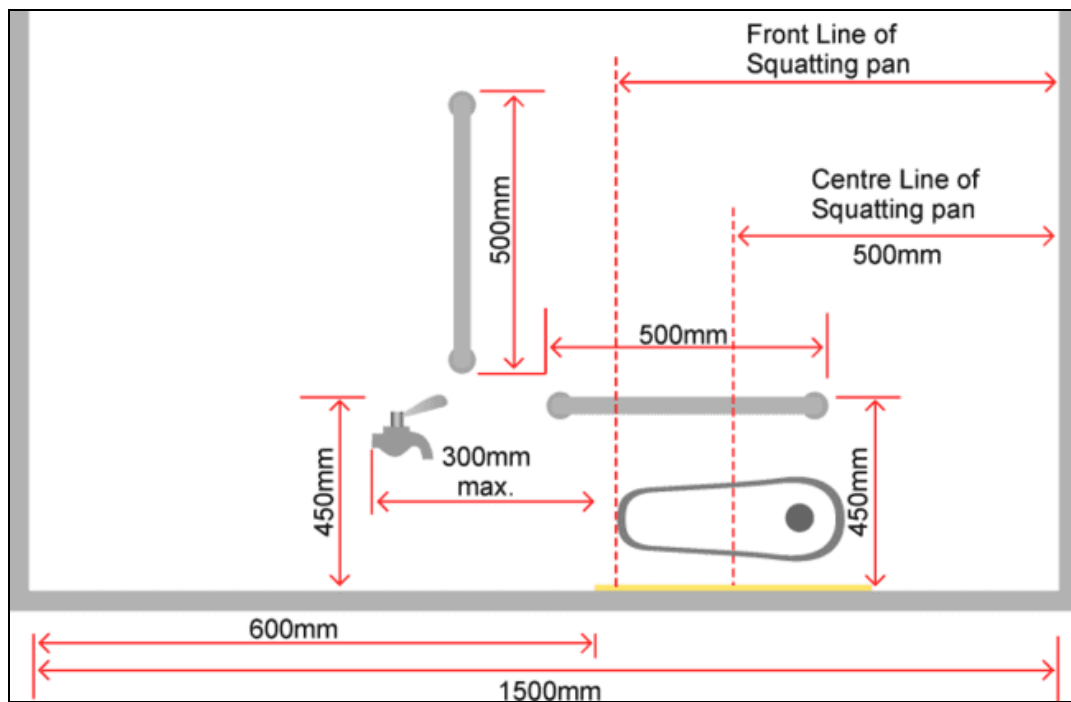

Figure 16-8. Side view of accessible squatting toilet

17. SPECTATOR SEATING AREA

In spectator seating in sports centres and stadiums with fixed seating, the number of spaces designated for wheelchair users in a seating area can be estimated according to Table 17-1:

Table 17-1: Seating for wheelchair users in halls/stadiums

Number of seats in a seating area	Number of required spaces for wheelchair users
up to 600	6 i.e. 1/100
up to 1000	6 + 2
over 1000	8+1 for each additional increment of 1000 seats

Some seats with removable or flip-up armrests should be provided at row ends to accommodate a wheelchair user or a person with limited ambulatory mobility. A level floor area for wheelchair users should be placed at row ends and should be scattered on different levels so as to have a variety of seating and viewing locations (Figure 17-1).

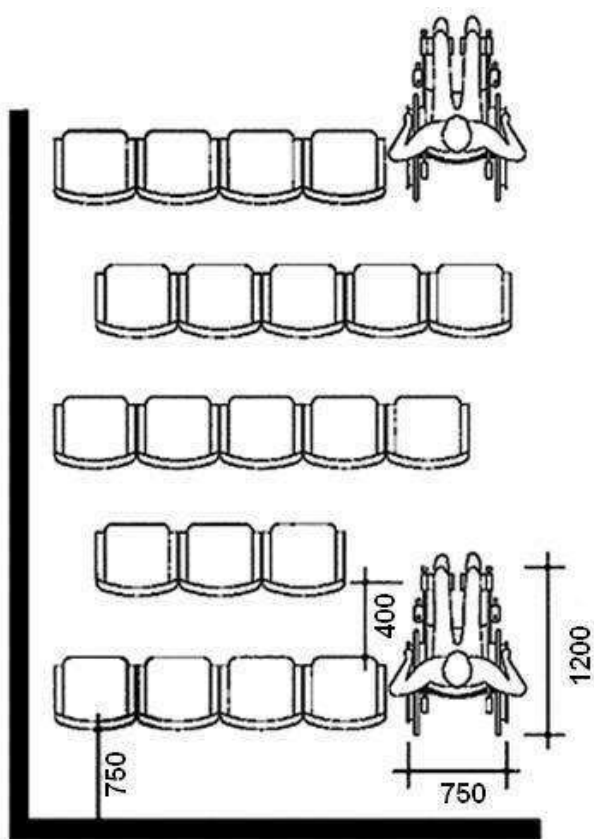

Figure 17-1. Wheelchair Seating Spaces

(Source: UNESCAP Guidelines)



Photo 17-1. Wheelchair reserved space with fellow visitors

(Photo Source: Samarthyam & Joseph Kwan)

18. Residential Facilities

18.1 WINDOWS

- **Windows:** should open inside the room and not in the corridor/circulation area
- **Height:** of the window should be 600-1450mm, enabling the resident to see out of it, when seated or in bed.
- **Operable devices:** such as handles, pulls, latches and locks should be:
 - provided between 850-1200mm
 - lever handles and push type
 - operable by one hand not requiring fine finger control, tight grasping, pinching or twisting to operate
- Remove glare from shining objects and window by providing blinds/curtains.

- Window glasses to be provided with wire mesh/grill with mosquito net to prevent insects and for safety of people with disabilities.

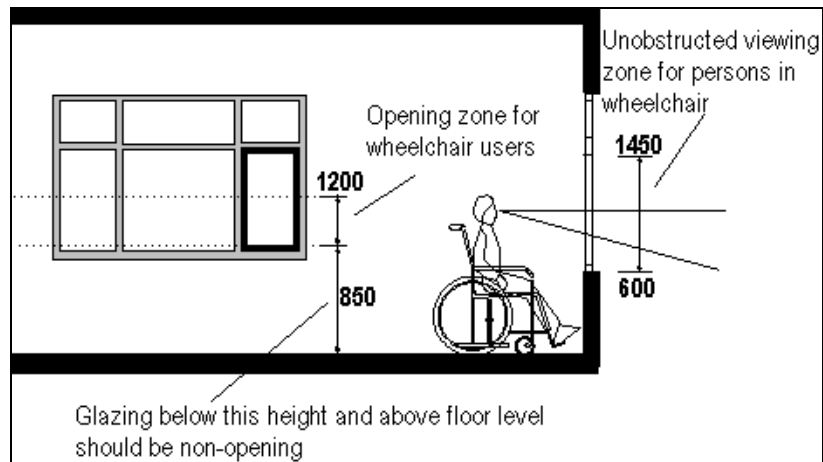

Figure 18-1. Window

(Source: UNESCAP Guidelines)

18.2 FITTINGS

- **Room:** Light/fan/AC switches to be provided at a height between 800-1000mm.
- **Alarms:** Audio and visual (flashing bulb) alarm facility should be provided in every room.

18.3 BED

- Adjustable beds/mobile units are recommended instead of fixed ones.
- Space around the bed should be 1000mm-1200mm minimum, for access and transfer by a wheelchair user or for a carer to assist in the transfer.
- Bed including the mattress height should be 450mm-480mm from the ground; this permits wheelchair users to transfer easily.
- There should be a bed-side table at 450mm-480mm and so positioned that permits a person lying on the bed to reach it easily.
- Switches/sockets (comprising of light, fan, night bulb, alarms, AC, etc.) should be provided near the bed between 500-800mm height.

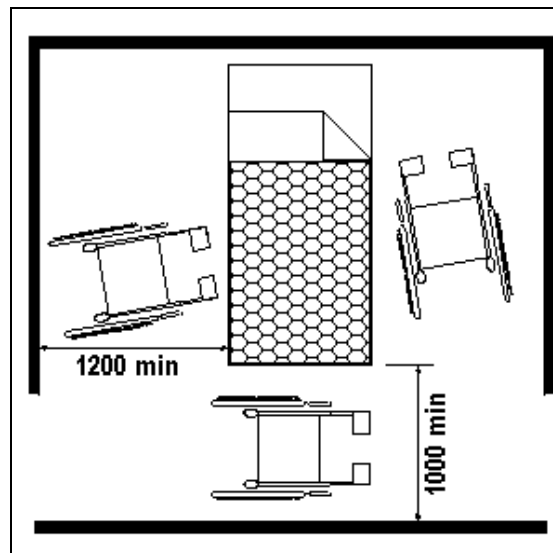

Figure 18-2. Maneuvering space around single bed

(Source: UNESCAP Guidelines)

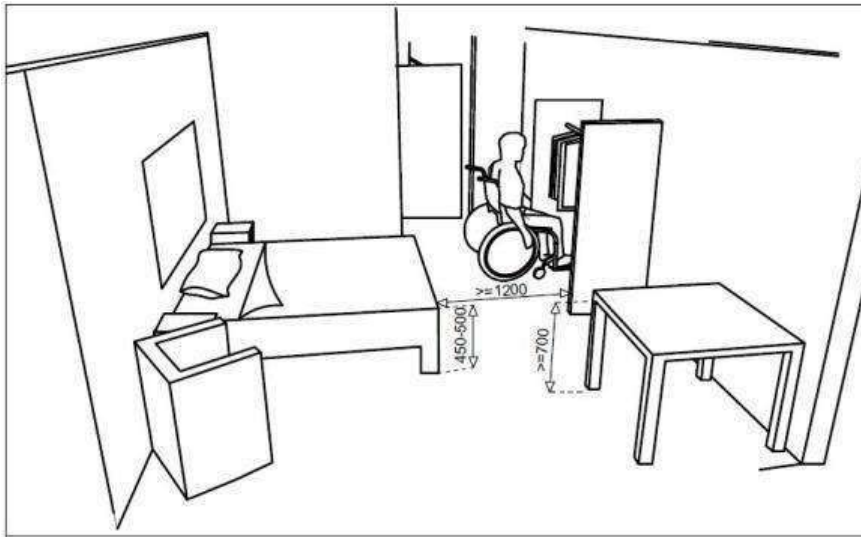

Figure 18-3. Layout of accessible double seater bedroom

18.4 MULTI-USE TABLES

- Activity/computer/dining tables should not be more than 800mm high from the floor, with a minimum knee clearance of 650-680mm high and 280-300mm deep.
- Space around the table should be around 1200mm x 800mm.
- Matt finish light colour table surface are recommended instead of glazed surfaces that produce glare.

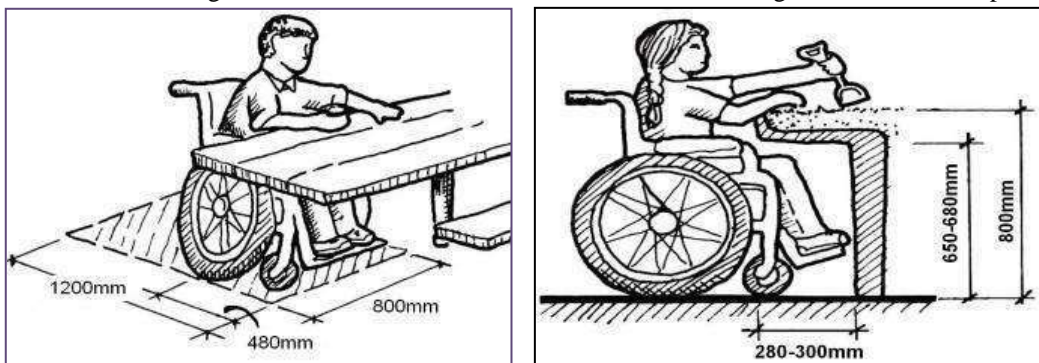

Figure 18-4. Space clearance for working tables

Pantry should be designed to be used independently by the residents with disabilities.

- **Working shelves/cooking range:** at 750-800mm height.
- **Sink:** at 750-800mm height with knee and leg space of 650mm for wheel chair users.
- **Taps:** having lever handle, not more than 400mm away from the edge of the sink.

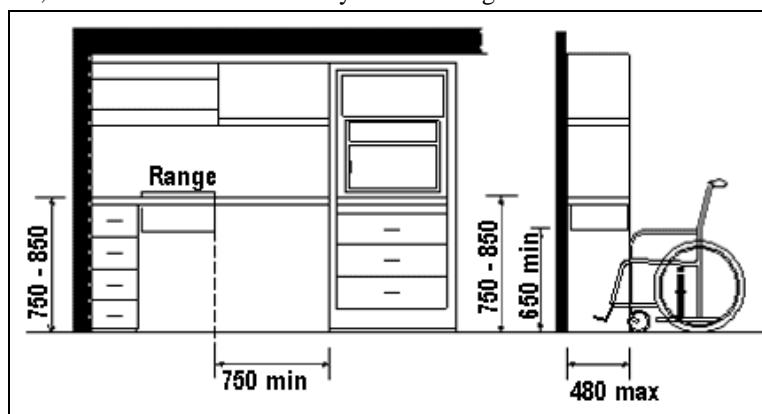

Figure 18-5. Serving/ cooking counter tops and cabinets

(Source: UNESCAP Guidelines)

18.5 STORAGE SPACE

- In the rooms/ activity area, storage space of various kinds (shelves, cupboards and drawers) should be 340mm-1200mm from the floor level, allowing front approach and 230-1300mm for side approach.
- Cupboard and drawer handles should be lever lock with D-shape handle, which may be easily grasped by a person with limited gripping or pulling strength.
- Sufficient floor space 900mm-1200mm should be provided for wheelchair users to maneuver around and open doors of cupboards/almirahs.
- Comfortable forward reach is between 380-1200mm and maximum height of shelves over worktop should not be more than 1300mm.

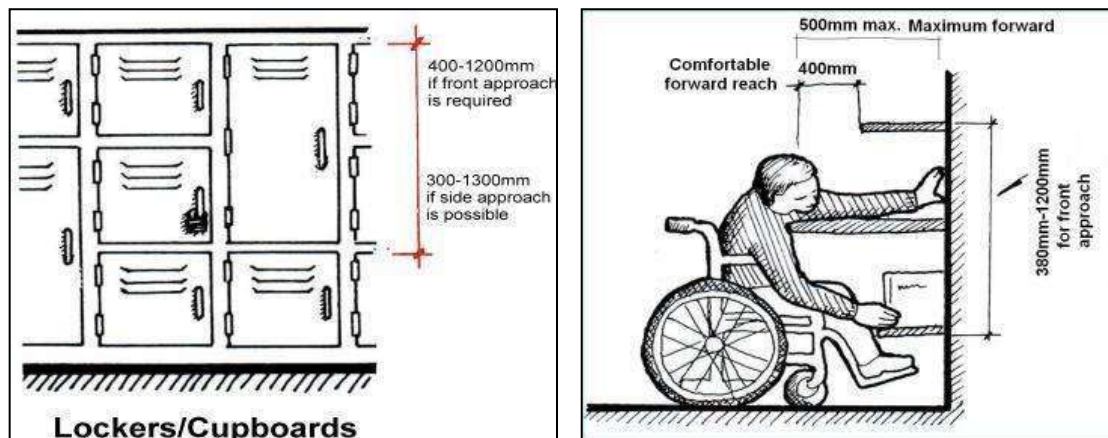

Figure 18-6. Storage and Lockers

(Source: UNESCAP Guidelines)

18.6 DINING AREA

- In self-service dining areas, tray slides and counters should be mounted at 800mm from the floor for wheel chair users. Aisle space of minimum 900mm should be provided (Figure 18-7).
- Cantilevered tables or tables with straight legs at each corner are preferable to central pedestals that might restrict wheelchair access.
- Stools and high tables are not suitable for mobility aid users such as wheelchair and crutch users. Low tables should be provided as well.

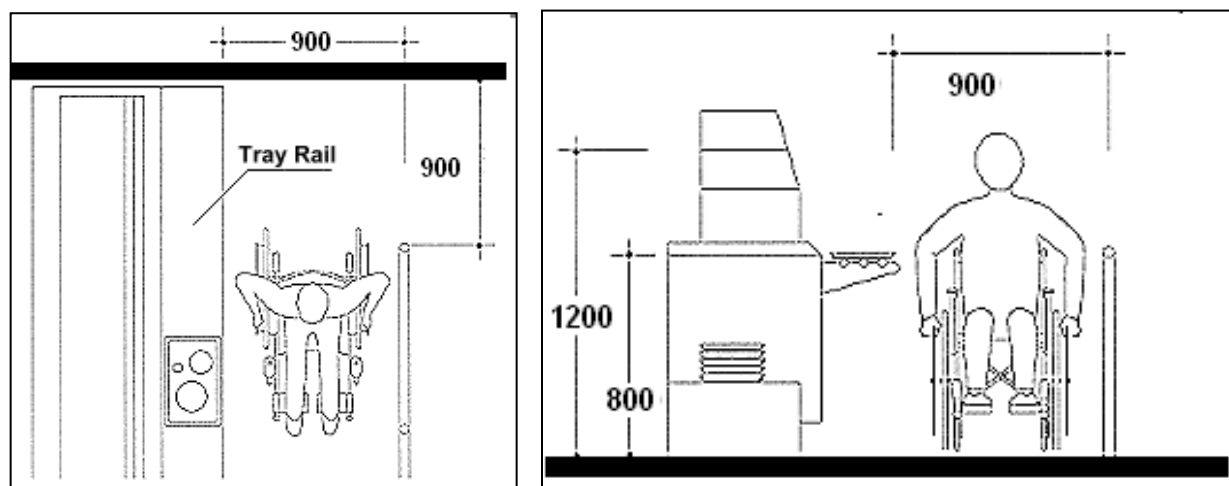

Figure 18-7. Wheelchair aisle space and reach height for self serving

(Source: UNESCAP Guidelines)

19. LUMINOSITY CONTRAST

Luminosity Contrast means adequate contrast created by difference of 26-30 LRV (Light Reflectance Value) between two surfaces/ objects and it helps everyone especially persons with visual impairments.

- Contrast colors should be provided between:
 - Critical Surfaces (walls, ceiling and floor),
 - Signage and background sign frame/ wall,
 - Step edges and risers/ treads on steps,
 - Handrails and background wall,
 - Doors and surrounding walls,
 - Switches/ sockets and background wall,
 - Toilet fixtures, accessories and background walls.
- Obstructions and hazards should be visible by incorporating colours and luminance contrast.



Photo 19-1. Colour Contrast



Photo 19-2. Luminance Contrast

(Photos Courtesy: Joseph Kwan)

20. Emergency Evacuation

In emergency situations, persons with disabilities should be immediately alerted and evacuated.

20.1 SAFETY

- **Boundary walls and Windows:** provide boundary walls for buildings and grills /net on windows, open areas, balconies, terrace, etc.
- **Residual Current Circuit Breaker (RCCB):** should be installed in the mains electric supply to trip in case of electric shock.
- **Safety Procedures:** to be provided and explained, in formats that are easily understood and take account of resident's communication needs.

20.2 REFUGE

Fire Refuge Area at the landing of a fire escape staircase, equipped with two-way communication gadgets with clear signage, flashing bulbs & audio signals to be provided to facilitate emergency evacuation. As a minimum requirement, refuges should:

- Have a 1400mm x 900mm space clear of the escape route, where a single refuge space is considered sufficient.
- Be provided with a 30 minutes fire-resisting self-closing fire door fitted with cold-smoke seals construction (integrity and insulation) from a fire inside the building, where the refuge is external.
- Be located either within, or be a space with direct access to, each protected stairway required for means of escape.
- Have a two-way communication system linked between the refuge and the management control point.
- Have clear signage indicating that the space is designated for refuge including identification of the floor level.
- Have a notice providing guidance on procedures in the event of fire.
- **Alarm Devices:** fire alarm boxes, emergency call buttons and lit panels should be installed between 800mm and 1000mm height from the furnished floor surface. These should be adequately contrasted from the background wall and should have embossed letters and Braille.
- Audible alarms with 'voice instructions' that can help guide people to the nearest emergency exit to be provided.
- Non-auditory alarms (visual or sensory) to alert persons with hearing impairments should be installed at strategic locations in all areas (including kitchen, toilet areas, etc.).
 - Flashing signals
 - Vibrating pillows
 - Vibrating beds

20.3 EVACUATION ROUTE

- Evacuation routes should be clearly identified at least 1200mm wide, to ensure that a person using a wheelchair and a non-disabled person are able to pass each other along the route. The route should be free of any level difference and should be kept free from obstacles such as furniture, coolers, AC units, flower pots, etc.
- Emergency exit lights in green color and directional signals mounted near the floor have been found to be useful for all people in cases where a lot of smoke is present.
- Use "Exit" signage along the route. Orientation and direction signs with arrows should be installed at a height of 500mm from the floor level along the evacuation route. These should be internally illuminated by electric light connected to corridor circuits.

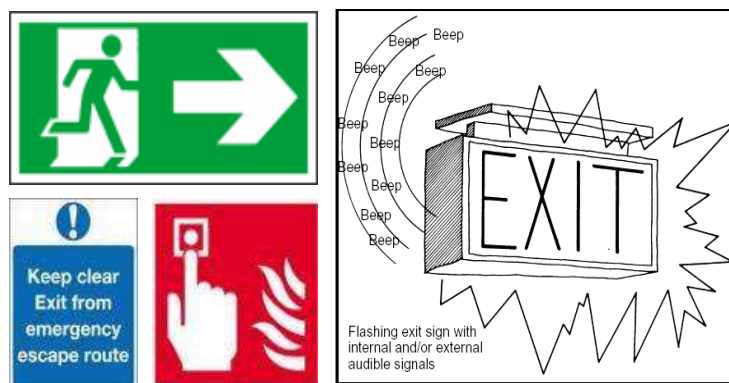

Figure 20-1. Exit Signage

21. Accessible Information & Communication, Services & Facilities

There are many services in the sports eco-system that can render the physical access futile, if not addressed. The services and infrastructure provided at district, state, national level that often feeds the next level of competitive sports are detailed herewith:

21.1 Information & Communication

i. Access to play field and sports arena

- A map that informs visitors how to reach their accessible parking from different directions to the stadium entrances should be provided.
- Facility to reserve in advance their parking space can also be provided through portal or an app so that they don't have to worry about finding a space once they arrive.

ii. Transportation Facilities

- For those who are, using public transportation can provided with an accessible subway or provided a map to reach to the area.
- Visitor Relations Booths located at every main entrance to answer any questions that people with disabilities may have about the stadium or public transportation and assist them accordingly.

21.2 Spectators/ Sports Persons with Disabilities

People with sensory sensitivity

- Information regarding the program can be provided in advance to the people with sensory sensitivity who may have issue with flashing lights or noise can be warned in advance upon request to be aware of the potential challenges. Knowing this in advance enables them to feel safe and in control.
- Availability of a sensory room- a quiet and soothing place for those who need silence when the activities of the game become too loud and too intense. People with Down Syndrome, Autism spectrum etc. can thus find a safe haven. The room with noise-cancelling headphones, ear plugs, sensory toys, low lighting shall be provided.

Visual Impairment

- Audio description for the sports persons with visual impairment
- Information booklet in Braille shall be provided for persons with visual impairment.
- Provides directional maps (visual & tactile) for both the exterior and the interior of the stadium.
- Downloadable version of the map or app can be provided with audio and visual to people with disabilities to help the sports persons in way finding.

Hearing Impaired

- Assistive listening devices for people with hearing impairment.
- Closed captioning for specific announcements and/or public addresses for the hearing impaired.
- Sign language interpreter shall be provided.
- Visual and textual information.

21.3 Apps/Web based information

- **Lowered counters at concession and merchandise stands.**
- **Sitting Arrangement**
 - Marked sitting areas with proper visual signage on the ground.
 - Area can be designated or it can be arranged in all segment to promote inclusion
 - Shall have wheelchair auto lock facility
 - Seat belt facility for persons with autism and sever intellectual disability.
- **Booking of ticket online or through app facility. Separate counter can be provided on arrival booking**

- **Toilet facility**

App should have the simple direction facility to guide users to the restroom.

21.4 Coach

- Ethical awareness and sensitization program have to be conducted
- If anyone encounters difficulties communicating with a person with disability, best way to communicate with one another shall be worked out.
- Coaches and volunteers should check with the participant about any support needs prior to the activity. It may help to get in contact with the relevant national charity for generic information and best practice.
- The more pre-planning coach do, the more positive experience the person with disability will have.
- All people with disability should have the choice between accessing disability sport or mainstream sport. All facilities and activity programmes should be inclusive to welcome people of all abilities.

21.5 Accessible elements for Athletes and Sports Persons

a) During Training

- There should be an area demarcated to keep the wheelchair when not in use.
- Uniform changing room facility can be arranged close to the grounds
- Accessible toilet facility should be nearby training area so athletes and sports persons do not need to walk a long distance.
- Pictorial signage should be displayed indicating the areas of facilities and volunteers should be provided to guide and support
- Physical assistance by trained guides or volunteers shall be provided during training whenever required.
- Athletic zone, gym, velodromes, internal & external sports facilities shall have accessibility elements.

b) Other specific needs

- Medical and treatment areas shall have all accessibility elements including the washrooms and changing rooms.
- Storage area shall have wider door for equipment storage and human assistance shall be made available for storing the sports and training equipment.
- Recreational area at the stadium for younger athlete to play
- Sensory equipment or developmental sports equipment can be provided
- Modified equipment, need- based and disability type based shall be made available
- Sitting arrangement for parents near to the training arena if moderate or profound athletes are practicing.
- Trained coaches who have the knowledge about the facility should provide training to the athlete
- Information about training schedule along with contact information and timing can be provide through app or at entrance booth.
- The information about training should be provided in simple Language and the volunteer and coach should be able to explain the information to them in simple language if required as per their understanding.

c) Curriculum

- Training curriculum to make sports facility accessible for all including those with intellectual disability, following steps shall be taken:
- Instruction shall be simplified and simple steps shall be given.
- The instruction should be conducted practically and explained as per their understanding.
- Whenever possible, it's advisable to provide pictorial model to make the understanding of the concept easier.
- Training on sports etiquette should be provided to the school teacher and disability training can be provided to the coaches or trainer.

- Training manual shall be provided in Braille also.
 - Sign language interpreters shall be made available.
- d) Safety**
- Medical room should be near the training ground or there should be an easy way to reach that room.
 - Trained doctor should be provided.
 - Adequate volunteer/ coach should be provided, so that the safety information can be explained to them in a very simple and easy to understand language.
- e) During Competition**
- Encourage well designed sports facilities that meet the needs of sports and are a pleasure to use.
 - The route from the changing room to the activity area e.g. sports hall or outdoor/indoor should be accessible.
 - Score board with audio and visual facility.
 - Award podiums shall have all accessibility features such as ramp, steps with handrails and tactile, and digital with audio system for announcements.
 - Direct access is provided to the shower area from the changing room.
 - Toilet provision is in very close proximity to the changing area.
- f) Lockers**
- Sufficient lockers should be set at varying heights and wide space to accommodate sports bags. Minimum reserved accessible lockers shall be 1:10
 - Locks and lockers should have clearly visible and embossed numbers that can be read by sight or touch.
 - Where there are large banks of lockers, some form of orientation assistance should be given.
 - Braille should be used wherever embossed characters are used.
- g) Flooring**
- Glossy surfaces should be avoided. Glare and reflection make it difficult for people to lip-read.
 - Use matt or mid-sheen finishes obtaining the maximum benefit from colour differentiation.
- h) Swimming pool**
- All pools must be designed to allow full integration of swimmers with disabilities in all activities.
 - Management should also provide integrated swimming sessions with additional support, as well as 'specialist' sessions for those who require specialized help or prefer segregated activities.
 - The route through a swimming pool complex should be the same for a swimmer with disability as a non-disabled swimmer.
 - Bare feet on wet floor surfaces make movement more difficult and more dangerous for people with mobility impairments. The surface needs to be skid free and soak absorbent matt can be provided
 - People with disabilities can often be self-conscious in a pool setting because they may be without their aids, are physically exposed, and may require assistance to enter the pool. Pool lift/ hoist are such as assistive devices which support entering into the pool (photo 21-1).



Photo 21-1. Pool lifts and hoist

(Photos Courtesy: Judy Wee)

21.6 Capacity Building and Awareness Raising Training

- Mandatory disability inclusive practices shall be promoted and this involves capacity building training at various levels for coaches, staff, human resource, permanent and contractual employees and any other personnel coming in direct interface with sports persons with disabilities.
- Training on disability etiquettes, terminologies, equipment handling, guiding in way finding and supporting visitors and sports persons with disabilities in toilet transfers are some of examples.
- All staff & volunteers to be trained in disaster management risk reduction and in evacuating persons with disabilities during disasters.
- Disability sensitization sessions are part of the staff induction programme.
- Staff is trained to assist persons with disabilities, including persons with learning disabilities.
- Reception staff is trained in basic Indian sign language.
- Staff is aware of the accessible facilities that are available and know how to operate them
- Trained live assistance is available in premises for all disability constituencies where it may be required.
- Sports facilities have a disability focal person in charge who manages the concerns of employees and clients with disabilities.

21.7 Accessible Field and Equipment's

- Beside the accessibility of infrastructure and public amenities, accessible equipment, playing / sports grounds, swimming pool, race tracks, tennis court, etc. shall be mandatory made available to sports persons with disabilities.
- All accessibility equipment is checked regularly and maintained well.

21.8 Associated Services

- Standards/checklist for organizing sports events/games/trials ensuring accessibility of travel, stay, location ensuring dignity and respect to persons with disabilities - both as sportsperson taking part as well as spectators shall be used as per details given in these guidelines.
- Accessible and disability inclusive processes to engage in sports, registration for events, and entire ecosystem where a person with disability can choose a sport, have counseling service to guide and help her/him take next step to move onto state/UT levels and at Central level shall be provided.
- Provision of the Sports Coach Training to senior players with disabilities shall be provided.
- Web/Mobile Applications, websites for promoting the access to information about sports & its various forms and registration / participation for training and competitions, filling up of forms, uploading of documents and credentials etc. shall be provided.

- Need of accessible transport services for persons with disabilities to attend practice sessions, sports events and travel from stay/ hotel areas to event areas shall be provided..

21.9. Adapted Sport Equipment

- Physical activity programs, equipment suitable to a wide range and kinds of disabilities shall be acquired, used and maintained. For example, in track and field athletes, provisions of specialized racing wheelchairs and throwing frames or specialized prosthesis need to be provided. For wheelchair basketball and wheelchair tennis, athletes may need specially designed and very light wheelchairs.
- Hence, disability and sports specific adapted equipment and assistive aids shall be specified in the policy, procurement rules / regulations, and provided & adapted as per individualized needs of persons with disabilities. There shall be coach/ guides who shall verify and support adjustments on ongoing basis/ need.

21.10 Disaster Management Plan

- All entry & exit points to be well highlighted
- Fire extinguishers and evacuation plan to be in Braille and audio version shall be made available

21.11 Checklist- Information & Communication

1.a	The website providing information about the building/service complies with web accessibility standards.
1.b	There is information detailing the accessible facilities in the building with pictogram.
2.	All publications/brochures are available in alternate accessible formats such as: Braille / Large Print / Audio / Pictorial / Easy-to-read/ Plain language /Available in Hindi & English and local language. - Accessible Electronic formats that can be shared over email or mobile platforms.
3	Printed service related documents such as forms; menu cards, etc. are in accessible formats.
4.	Forms can be filled electronically through accessible software.
5.	Additional support is available to fill written forms, if required.
6.	Staff is trained in Indian Sign Language interpretation. If not, then Sign language interpreters are available on call.
7	Assistive technology such as Loop Induction system, Audio orientation tools, interpretative video's in with captioning or sign language, wheelchairs etc. are available.
8.	There is adequate and uniform lighting and no glare or dark spots for persons with low vision and persons with hearing impairment.
9.	Adequate support is available for persons from different cultures, learning disabilities, those not formally educated, in all the above provisions.
	There is a procedure for visitors/with disabilities to lodge a complaint or make suggestions.