

**RFP Document**

**Request For Proposal (RFP)**

**Comprehensive Annual Maintenance Contract (CAMC)**

For

Haryana Edusat Network

UTKARSH Society

UTKARSH Society, EDUSAT Block, DIET Campus,

Sector-2, Panchkula (Haryana)

Tele/Fax: 0172-2587710, 2587403

## INDEX

Sr. No.	Description	Page No.
1.	Introduction	3
2.	Scope of Work (CAMC with Existing Technology)	4-5
3.	Terms & Conditions	5-8
4.	CAMC with Technology Upgradation/Change of VSAT Technology Option	9-11
5.	Payment Terms & Conditions	11-12
6.	EMD	12
7.	Performance Bank Guarantee (PBG)	12
8.	Validity of Bids	13
9.	Procedure for submission of bids	13-14
10.	Schedule / Dates	14
11.	Penalty Clause	14-15
12.	Escalation Matrix	15-16
13.	Fall Clause	16
14.	Force Majeure	16-17
15.	Arbitration	17
16.	Termination of contract	17
17.	Addition/Deletion Clause	17-18
18.	Rights regarding cancellation of RFP, acceptance & rejection of any bid(s)	18
19.	List of equipments of HUB (SIT & ROT) System, Teaching end & SIT for CAMC - <b>'Annexure – I'</b>	19-21
20.	Schematic Block Diagram of the existing HUB, TE & SITs of Haryana Edusat Network- <b>'Annexure -II'</b>	22-23
21.	Addresses & Contact Details of Coordinators - <b>'Annexure - III'</b>	24
22.	Financial bid for the CAMC of HUB (SIT & ROT) System, Teaching End (TE), 250 SITs <b>'With Existing Technology'</b> for Two Years (1 <sup>st</sup> & 2 <sup>nd</sup> Year) - <b>'Annexure – A'</b>	25
23.	Financial bid for the CAMC of HUB (SIT & ROT) System, Teaching End (TE), 250 SITs <b>'With Existing Technology'</b> for 'Third' & 'Fourth' Years - <b>'Annexure – B'</b>	26
24.	<i>FINANCIAL BID</i> -Cost of Spares/Subsystems of HUB (SIT & ROT) System, TE & 250 SITs - <b>'Annexure – C'</b>	27-31
25.	Financial bid for the <b>"Technology Upgradation</b> of existing HUB (SIT & ROT), Teaching End (TE), 250 SITs <b>AND</b> CAMC of HUB (SIT & ROT), Teaching End (TE), 250 SITs for 'Two Years' (1 <sup>st</sup> & 2 <sup>nd</sup> Year) after the "Technology Upgradation"- <b>'Annexure – D'</b>	32
26.	Financial bid for the CAMC of HUB (SIT & ROT) System, Teaching End (TE), 250 SITs 'after the technology upgradation' for 'Third' & 'Fourth' Years - <b>'Annexure – E'</b>	33
27.	Escalation Matrix – <b>'Annexure-F'</b>	34

## **1.0 Introduction:-**

ISRO has established a satellite based Tele-education Network to meet the requirement of various users in education sector across the country. **Haryana Edusat Network** is the biggest network under Tele-education programme which was implemented in phase manner from 2006. It consists of 1 Ku-band HUB (SIT & ROT) System & Teaching ends, which are located at UTKARSH Society, Edusat Block, DIET Campus, Sector-2, Panchkula (Haryana). This network also consists of 512 nos. of SITs (Satellite Interactive Terminals) installed at various Sr. Sec. Schools, Colleges, Polytechnics, other Offices and 10306 nos. of ROTs Installed at various Primary, Sr. Sec. Schools across the Haryana State. Equipments of HUB & SITs (major OEM is M/s Viasat) were supplied, installed & commissioned by M/s. Bharat Electronics Limited. Equipments of ROT (Receive Only Terminals) sites were supplied, installed & commissioned by M/s. BEL & M/s. MCBS. Presently, the network is operational using Satellite bandwidth of 10MHz, in Ku band on INSAT-4CR Satellite. This network is having 01 Interactive and 04 ROT (Broadcast) Channels. At present the network is out of AMC coverage.

This Network need to be maintained for effective utilization in order to continue & enhance distant learning through satellite based system. Keeping this in view, UTKARSH Society,Panchkula has floated this Request For Proposal (RFP) for awarding the “Comprehensive Annual Maintenance Contract” (CAMC) for the Haryana Edusat Network which includes HUB System for SIT & ROT ( 1 no.), Teaching end (1 no.) and 250 SITs under CAMC coverage with following two options:-

**Option-1** CAMC with existing technology

**Option-2** CAMC with Technology Upgradation

Schematic block diagram of existing Ku band HUB & SIT system is given in ‘Annexure-II’

## 2.0 Scope of Work:-

- 2.1 Bidder shall be responsible for carrying out “On–Site” Comprehensive Annual Maintenance Contract (CAMC) for the following:-
- I) Ku Band HUB (SIT & ROT) System (with 3.8 Meters antenna/25 Watts BUC system) (including 10KVA UPS) and a co-located Satellite Interactive Terminal (SIT) at UTKARSH Society, Edusat Block, DIET Campus, Sector-2, Panchkula (Haryana). **(Quantity- One Number)**
  - II) Teaching End (TE) including UPS at UTKARSH Society, Edusat Block, DIET Campus, Sector-2, Panchkula (Haryana). **(Quantity- One Number)**
  - III) Ku-band Satellite Interactive Terminals (SITs) (with 1.2 Meters antenna/2 Watts BUC system) including UPS, spread across Haryana State. **(Quantity- 250 Numbers)**
  - IV) The list of equipments & subsystems to be covered under CAMC of HUB (SIT & ROT) system, Teaching End & SITs is given in **Annexure-I**.
- 2.2 The term ‘Comprehensive Annual Maintenance Contract (CAMC)’ means that, Bidder shall diagnose the faults, repair/replace the faulty items, equipments, systems, components, peripherals, softwares, firmwares installed in HUB system, Teaching end and SITs using its own (bidder’s) resources and equipments within given time frame to make HUB, Teaching end & SITs operational.
- 2.3 CAMC includes all Hardware, Operating system, Software of HUB (SIT & ROT) system, Teaching end, SITs & UPS such that CAMC ensures total network connectivity, end to end between SITs with teaching end through HUB and ROT broadcast from HUB System.
- 2.4 Bidder shall carry out Preventive Maintenance atleast once in every 6 Months (Twice in a year) for HUB & Teaching end and once in a year for Remote Satellite Interactive Terminals (SITs). The Bidder shall carry out corrective maintenance/break down maintenance as and when required.
- 2.5 Bidder has to prepare detail maintenance report for each maintenance activity carried out for HUB (SIT & ROT) system, Teaching end & SIT and submit to UTKARSH Society, Panchkula.
- 2.6 Bidder shall carry out maintenance for existing versions of ‘software & firmware’ of HUB system. Bidder shall also provide software & firmware maintenance for Teaching end and SITs by loading of software & firmware, if required to keep the systems fully functional.

- 2.7 Bidder shall provide maintenance services for TrainNet Server, Teaching end Software which includes free upgrades, free maintenance updates, bug fixation, etc. for Haryana Edusat Network during period of CAMC.
- 2.8 Bidder shall provide maintenance, updates of existing Antivirus software, Server at HUB, TE and clients at remote SITs ends.

### 3.0 Terms & Conditions:

- 3.1 Bidder has to visit HUB & Teaching end site at UTKARSH Society, Sector-2, Panchkula (Haryana) and find out operational status (upfront verification). If any equipment is found faulty, Bidder has to replace it and make it operational. Bidder shall quote the charge for faulty units, if any. The Bidder shall also provide the financial bid for the cost **(in Annexure – C)** of HUB, Teaching End, & SIT equipments/subsystems along with financial bid for CAMC **(in Annexure – A,B)**.
- 3.2 Bidder has to find out the operational status (upfront verification) of SITs from HUB using remote access to declare the number of operational SITs which are to be taken in to CAMC coverage from the date of award of contract. (The SIT can be considered operational only after successful two way Audio & Video interaction between SIT and teaching end).
- 3.3 The Bidder shall visit to those remote SIT sites which are not working (Non-operational) as observed from HUB. During this visit, Bidder shall diagnose the fault & prepare a site audit report and get approval from UTKARSH Society for replacing the faulty units. The Bidder will make the system (SIT) operational by replacing/repairing the faulty units including the consumables (excluding batteries of UPS).

The working Unit/Subsystem of SITs which are replaced to make SIT operational may be available with following options:-

**Option a:** - The Bidder may use working subsystem of SITs which are available at UTKARSH Society. UTKARSH Society will make arrangement to bring all working units/subsystems of SIT from remote SITs, which are not in use (i.e. 262 SITs out of 512).

If required by UTKARSH Society, bidder has to visit remaining unused 262 SITs (other than 250 out of 512) and bring all working units/subsystems of SIT except Antenna at UTKARSH Society, Panchkula. Bidder should quote for visit charge (including transportation charges) for this activity.

**Option b:** - The Bidder may provide new working units/subsystems of SITs for replacement at its own. The Bidder shall quote the visit charge for the site and charge for faulty units which is to be replaced. The Bidder shall provide the financial bid for the cost of each subsystem & peripherals of SIT (in Annexure-C) along with the financial bid for CAMC (Annexure-A,B).

- 3.4 Bidders shall submit certificate from Original Equipment Manufacturer (OEM) or their authorized Indian Representative stating the authorization & confirmation to support CAMC as per RFP for
- I) M/s ViaSat HUB & SITs
  - II) M/s ROBO Group for TrainNet Software (LMS for teaching end and Student end)
- 3.5 Consumable items (Only Batteries of UPS & lamp of Projectors) are not covered under CAMC. However, issues related to connectivity of 'batteries & lamp' with 'UPS & Projector system' respectively are under the scope of CAMC.
- 3.6 Bidder shall provide a single contact point with dedicated Help Desk at Panchkula/ Chandigarh for all break down calls reported during CAMC period. Help desk shall have a contact phone no., Email, FAX, & address etc. and shall be available from Monday to Saturday from 9:00 Hrs to 18:00 Hrs to carry out the activities under the scope of CAMC. Bidder must provide complaint/docket number to user and maintain log book. In case of emergency, operations or complaints, Bidder shall extend maintenance support on 24 x 7 basis. UTKARSH Society will provide sitting space (*for 1 or 2 persons only*) for the 'Help Desk Staff of bidder' at UTKARSH Society, Panchkula, if required by the bidder. The other necessary facilities for help desk (like telephone, internet Fax, computer, Printer, stationery items etc.) shall be the arranged by the bidder. Bidder shall also provide the 'Online System' to UTKARSH Society for the registration of complaints, complaint status/monitoring, status of action taken by bidder on the registered complaint, final status of the complaint, history of each & every complaints, Date of Complaint Registration, Date of Complaint solution, Down time and penalty details (according to the RFP document) in respect of complaints of HUB, TE & 250 SITs. The 'Online System' should be capable to generate the necessary reports. Bidder shall also provide a Toll Free Phone number for above said purpose. Successful bidder shall fill the visit status in "Complaint Record Register" of individual site & submit the attested copy of 'Complaint Record Register' (with Date of Complaint Registration & Call Closure Report) of site under CAMC along with their 'Service Report'. The format for 'Service Report' will be decided later (before signing the contract agreement).

- 3.7 Bidder shall depute a qualified engineer to provide quick response and solution for maintenance requirement during the CAMC period. The engineer shall be specifically trained in handling of maintenance of the HUB (SIT & ROT) System, TE & SIT Network (including all Hardware, Operating Systems, software, firmware, TrainNet LMS etc.). The Bidder must follow the maintenance guidelines as specified in the service manuals of the OEMs of HUB, teaching end & SIT equipments.
- 3.8 All logistics like arrangement of required equipments, transport of equipments and lodging/ boarding of maintenance personnel shall be the responsibility of Bidder.
- 3.9 In the event of the damages to user's property or personal injury to user/Bidder personnel due to negligence of employee, the responsibility shall be solely rest with Bidder.
- 3.10 UTKARSH Society, Panchkula (Haryana Edusat Network) user agency shall not be responsible for the loss of life of employee of Bidder at the time of execution of contract at user agency's premises due to accident/natural calamities/explosion etc., if any.
- 3.11 The persons engaged by the Bidder for carrying out the maintenance work will not have any right or claim for regular employment in UTKARSH Society/Education Department, Haryana.
- 3.12 Bidder shall provide two way transit insurance along with indemnity bond for security of material whenever items are handed over by UTKARSH Society for repair/ replacement.
- 3.13 Bidder shall coordinate with Administrative Officer (UTKARSH Society, Panchkula) for Road permit/way bill for movement of material 'to & from' the sites of Haryana Edusat Network. The road permit/way bill for movement of material (within Haryana State) shall be arranged by Administrative Officer (UTKARSH Society, Panchkula) and handed over to Bidder.
- 3.14 The rates quoted for the Spares, Equipments, CAMC etc. shall inclusive of all types of taxes, custom duties, duties as applicable, transportation charges & insurances etc. Nothing over and above the quoted rates shall be payable.
- 3.15 Bidder shall coordinate with coordinator of UTKARSH Society, Panchkula & concerned site incharge for any support during CAMC.
- 3.16 CAMC shall be awarded initially for a period of 'Two years' (1<sup>st</sup> & 2<sup>nd</sup> Year) and may be extended for further 'Third year' &/or 'Fourth year', if required by UTKARSH Society. The extension of CAMC for the 'Third year' &/or 'Fourth year' depends on

the decision of UTKARSH Society, Panchkula and on the work performance of the bidder.

- 3.17 Bidder shall prepare required CAMC Certificate along with maintenance service reports of each maintenance activity carried out for HUB (SIT & ROT) system, TE & SITs and get duly certified by coordinator/concerned site incharge of UTKARSH Society, Panchkula.
- 3.18 During the CAMC period, if need arises for shifting of any SIT &/or TE to new location, Bidder shall take care of CAMC for SIT/TE installed at new location.
- 3.19 The maximum permissible down time is 2 (Two) working days for HUB (SIT & ROT) System & Teaching end and 7 (Seven) working days for SIT site. To meet this down time, Bidder shall stock sufficient spares at local office in Panchkula/Chandigarh. Parts/ equipments replaced & duly repaired shall be of same type & capacity. In case any parts replaced by lower capacity; the original capability of system should be restored within 3 (three) months. System should be functional in these 3 (three) months also. In case of non availability of identical replacement, suitable new equivalent replacement with similar or better specification shall be carried out by the Bidder with the approval of UTKARSH Society, Panchkula.
- 3.20 **Pre Bid Meeting:** - Prior to the submission of bids (Technical & Financial bid), a pre bid meeting will be held on **26/08/2013 (at 11:00 AM)** at “**Conference Hall, UTKARSH Society, Edusat Block, DIET Campus, Sector-2, Panchkula (Haryana)**” for understanding the requirements of RFP clearly. It is mandatory for the bidders to attend the pre bid meeting. If the meeting is not able to cover all the bidders on 26<sup>th</sup> the meeting will continue on 27<sup>th</sup> i.e. 27/08/2013.
- 3.21 Bidders shall attend the ‘Pre Bid meeting, Opening of bids or any other meeting fixed by UTKARSH Society,Panchkula related to RFP’ at bidder’s own cost.
- 3.22 **Duration:** Initially, the duration of the CAMC is for ‘Two years’ (1<sup>st</sup> & 2<sup>nd</sup> Year) only. However, it may be extended to ‘Third year’ &/or ‘Fourth year’ depends on the decision of UTKARSH Society, Panchkula.
- 3.23 For CAMC, bidder shall submit the combined quote for the ‘Two years’ (1<sup>st</sup> & 2<sup>nd</sup> Year) as per format given at ‘**Annexure – A**’ / ‘**Annexure – D**’. Bidder shall also submit the CAMC quote for ‘Third year’ & ‘Fourth year’ in the ‘**Annexure – B / E**’, separately.
- 3.24 UTKARSH reserves the right to modify any clause or terms & conditions of RFP during pre-bid meeting and submit revised RFP to vendors for sending quote.



#### **4.0 CAMC with Technology Upgradation/Change of VSAT Technology Option: -**

Bids are also invited for the CAMC of HUB (SIT & ROT), Teaching End and 250 SITs with Technology Upgradation option.

4.1 Under 'CAMC with Technology Upgradation' Option, Bidder shall upgrade the existing technology of existing HUB (SIT & ROT) system, Teaching End & 250 SITs with latest Technology other than ViaSat Technology. Bidder shall supply the necessary equipments for the Technology Upgradation in the 'buyback of existing equipments' which are required to replace for the Technology Upgradation. Bidder shall provide the CAMC services after successful Technology Upgradation/ change of VSAT Technology.

4.2 Bidder shall study the schematic block diagram of Hub, TE & SIT (Annexure-II) and decide/supply the equipments which are only necessary for change of VSAT technology for making network operational.

4.3 Bidders shall provide the technical details of the technology upgradation, comparison between 'existing technology of Haryana HUB, TE, SIT's and 'Upgraded Technology' with advantages & disadvantages/limitations of both as a part of technical bid.

4.4 Bidders shall give the presentation on the 'Technology Upgradation' of Haryana Edusat HUB, TE & SITs at the time of Pre Bid Meeting.

4.5 Bidders shall demonstrate the 'functioning of similar Upgraded Technology' on a running similar Edusat Network to the committee of UTKARSH Society. Concerned bidder shall arrange the demonstration (including necessary permissions) at his own cost. However, UTKARSH Society will arrange the conveyance, boarding & lodging etc. for committee members of UTKARSH Society, Panchkula.

Bidder shall give above said demonstration after the Pre Bid Meeting but well before the last date of the submission of bids. Suitable Date & Time for demonstration will be fixed by the UTKARSH Society, Panchkula after consulting with the concerned bidder.

4.6 Bidder shall successfully supply, Install & commission the all necessary equipments, hardware, Operating systems, Software, firmware, miscellaneous items etc. of upgraded technology at the HUB, TE & SIT sites of UTKARSH Society. Bidder shall be 'OEM or OEM's authorized Indian Representative' of such supplied equipments. Bidder shall integrate their supplied equipments with existing equipment setup of HUB, TE & SITs to ensure end to end connectivity and made network operational.

4.7 Bidder shall provide 03 years on site warrantee of the supplied equipments (including Hardware, software, firmware etc.). Bidder shall perform maintenance of the supplied

Software & firmware (which includes free upgrades, free maintenance updates, bug fixation etc.) during warrantee period of 03 years. Warrantee period will start from the date of successful commissioning of supplied equipments after installation & integration.

- 4.8 All supplied equipments must be fully compatible & functional with the rest of equipments of existing HUB (SIT & ROT), Teaching end & 250 SITs to ensures total network connectivity, end to end connectivity between SITs & ROT broadcast to sites with Teaching ends through HUB (SIT & ROT). Bidder shall ensure the full compatibility & functionality of all equipments with the existing systems setup, satellite bandwidth etc.
- 4.9 The execution time for the 'Technology Upgradation process' is 45 Days. Bidder shall complete all the activities related to Technology Upgradation within 45 days from the date of award of work.
- 4.10 Haryana Edusat Network is running network, transmitting & broadcasting the scheduled programmes for 10818 sites (SIT& ROT) for the students of Haryana State. In view of this, bidder shall provide the maximum feasible 'up-time' of network during the 'Technology Upgradation process'.
- 4.11 After starting the work of Technology Upgradation by the bidder, if the bidder fails to upgrade the existing technology due to 'any reason at any stage' then bidder shall revert back the system (HUB (SIT& ROT), TE, SITs) to the existing technology & configuration with its existing original equipments, systems, Subsystems at his own (bidder's) cost within 15 days. In case of failure in the 'Technology Upgradation', Bidder shall return the HUB (SIT & ROT), TE, SITs systems in proper working condition with existing technology to UTKARSH Society, Panchkula. In this case bidder shall reinstall, reconfigure, recommission, reintegrate the existing original equipments to ensure proper end to end connectivity of the Haryana Edusat Network. In case the bidder is unable to execute the technology upgradation work, then the PBG deposited by the bidder will be forfeited.
- 4.12 Under Technology Upgradation Option initially, the bidder shall submit the all equipments/spares of existing technology to UTKARSH Society, Panchkula which are removed from the system for Technology Upgradation. The existing equipments/spares submitted by the bidder will be released along with the 60 % payment after six month of successful implementation of the setup.
- 4.13 Under "CAMC with Technology Upgradation Option", bidders shall also provide the financial bid for the cost of each subsystem & peripherals of HUB (SIT & ROT), TE & SIT (in Annexure-C) along with the financial bid for the CAMC (Annexure-D,E).

- 4.14 Rest of 'Scope of work', 'terms and conditions' etc. for the "CAMC with Technology Upgradation Option" will remain same as mentioned in RFP document for the "CAMC with existing Technology Option".
- 4.15 Under Technology upgradation option initially the supplied equipments are under warranty for three years. However, vendor has to undertake CAMC of rest of Hub, TE and SIT equipments and give their quote for CAMC of these equipments for two years.

## **5.0 Payment Terms & Conditions:-**

- 5.1 Payment of CAMC charges for the HUB, Teaching End will be done on pro-rata basis at the end of each Quarter (3 months) after completion of satisfactory services.
- 5.2 Payment of CAMC charges for the SITs will be done on pro-rata basis at the end of each Quarter (3 months) after completion of satisfactory services.
- 5.3 For each payment of CAMC, Bidder shall submit the Invoice along with user certified documents and approval of Administrative Officer (UTKARSH Society, Panchkula) at the end of each Quarter for the payment of CAMC charges. Processing time for the payment of CAMC Charges will be less than 45 days after the date of submission of invoices (with required documents & approval) to the UTKARSH Society by the Bidder.
- 5.4 UTKARSH reserves the right to add or delete any SITs on Pro-rata basis with the same rate during tenure of CAMC. The SITs which are in working order shall be added/deleted to the CAMC at the discretion of UTKARSH. Any deletion/addition of SIT from the CAMC will be effective at the beginning of quarter.
- 5.5 Any item found faulty during first visit/upfront verification will be replaced/repared by the Bidder. Charges of repair/replacement will be done according to final accepted amount quoted by the bidder for all subsystem of HUB, TE & SITs.
- 5.6 In case of Technology Upgradation option, the payment of the supplied equipments (including supply, I&C , Integration) will be done to the bidder in following manner:-
- a) '40 % payment of the final accepted amount of equipments' will be done after the successful delivery, installation, commissioning and integration of the supplied equipments on the production of satisfactory I&C, Acceptance Report. I&C, Acceptance Reports must be duly verified from Nodal Officer of UTKARSH Society.
  - b) Rest of '60 % payment of the final accepted amount of equipments' will be done after six months from the date of 'successful commissioning & integration' after observing the proper functioning of supplied equipments & upgraded technology to the satisfaction of UTKARSH Society, Panchkula.

5.7 All transaction shall be in Indian Rupees. All payment will be made after deduction of TDS as applicable.

## **6.0 EMD:-**

6.1 As part of technical bid, Bidder shall furnish an EMD of amount Rs. 50,000/- (Rupees fifty thousand only) with the bid in favour of the **UTKARSH Society, payable at Panchkula, Haryana.**

6.2 The EMD shall be in the form of Bank Draft from any Nationalized/Scheduled Bank of India and will not be liable for any interest. The EMD should be valid for a period of 180 days from the date of submission of bid.

6.3 Any bid, not containing the proper EMD will be rejected as non-responsive.

6.4 EMD of unsuccessful bidder's will be discharged/returned as promptly as possible, but not later than 60 days after the expiry of the period of bid validity.

6.5 Earnest Money of the successful bidder will be released once the bidder signs the agreement and furnishes the performance guarantee.

## **7.0 Performance Bank Guarantee (PBG):-**

7.1 Within 7 (Seven) days of the notification of "Award of Work", the Bidder shall furnish a Performance Bank Guarantee (PBG) to UTKARSH Society @ 5% of the 'total contract value of CAMC' by way of irrevocable and unconditional Bank Guarantee in favour of 'UTKARSH Society, Panchkula' for a period to be specified in the "Award of Work" (according to final duration of CAMC).

7.2 In case of '**Technology Upgradation Option**' in addition to above mentioned PBG for CAMC (i.e. 5 % of the 'total contract value of CAMC'), the Bidder shall also furnish a Performance Bank Guarantee (PBG) @ '20% of the total cost of supplied equipments under Technology Upgradation option' by way of irrevocable and unconditional Bank Guarantee in favour of 'UTKARSH Society, Panchkula' within 7 (Seven) days of the notification of "Award of Work". The duration of PBG will be atleast 39 months to ensure the proper services by the bidder during warrantee period.

7.3 This PBG should be of sufficient duration to cover the risk of UTKARSH Society, Panchkula. The proceeds of the PBG shall be payable to the UTKARSH Society, Panchkula as compensation for any loss resulting from the Bidder's failure to fulfill its obligations under the terms and conditions of the work order.

7.4 EMD and PBG deposited to UTKARSH Society shall bear no interest. UTKARSH Society will not be liable for any type of claim regarding interest on EMD and PBG.

## 8.0 Validity of Bids:-

- 8.1 Bids shall remain valid for 180 days from the last date of bid submission. A Bid valid for a shorter period shall be rejected as non-responsive.
- 8.2 In exceptional circumstances, UTKARSH Society, Panchkula may solicit Bidder's consent for the extension of the period of bid validity. The 'request' and the 'response to the request' shall be made in writing. The validity of EMD shall also be suitably extended. A Bidder granting the request to modify the bid is neither required nor permitted.

## 9.0 Procedure for submission of bids:-

- 9.1 Bidders shall submit their bids for 'Option-1 (i.e. CAMC with existing technology)' **OR** 'Option-2 (i.e. CAMC with technology upgradation)' **OR** 'Both Options-1 & Option-2'.
- 9.2 Bidders shall submit their bids as per procedure mentioned below: -

- a. **Part I:- Technical Bid**– It will consist of the company/establishment profile indicating the capability, self attested documentary proof of experience, signed bid document, EMD and other documents/statutory requirement certificates from OEMs as mentioned in the terms & conditions. This first envelope shall be superscribed as **“Technical Bid”**.
- b. **Part II:- Financial Bid** – It will contain the all quoted rates (on Annexure- 'A' to 'E') for the 'Spares / Equipments', 'CAMC for HUB, Teaching End & SITs' including all types of taxes, custom duties, duties & transportation charges etc. This second envelope shall be superscribed as **“Financial Bid”**.

Both these envelopes after being sealed properly shall be put into a third envelope, which should be properly sealed before it is sent/submitted. The third sealed envelope (superscrib as **“Bid for the CAMC of Haryana Edusat HUB, Teaching End & 250 SITs”**) shall be addressed to the **'Administrative Officer, UTKARSH Society, Edusat Block, DIET Campus, Sector-2, Panchkula (Haryana)'**.

- 9.3 Bidders shall submit the following details/documents as part of Technical Bid:-
  - a. Valid registration Number of the firm for the VAT/Service Tax purpose.
  - b. Income Tax Return for the last financial Year.
  - c. Document related to total years of experience in providing CAMC of HUB (SIT & ROT) system, Teaching end and SIT sites.
  - d. Form 16 A (copies) issued by the Government Organizations/reputed organization deducting TDS on CAMC services provided by the firm.
  - e. List of Government, reputed private organization who renewed the CAMC with the firm, with copies of orders.

- f. Signed copy of complete RFP Document along with scope of work, terms & conditions.
  - g. EMD as mentioned at point no. 6.0 above.
  - h. A valid authorization certificate from the Original Equipment Manufacturers (OEMs) as mentioned at point no. 3.4 above.
  - i. Any other document as per RFP document.
- 9.4 Bidder shall quote the rates of CAMC, spares (Annexure- 'A' to 'E') as part of Financial Bid. Bidder should write the amount 'in figures' as well as 'in words' without any cutting & over writing.

**10.0 Schedule / Dates: Important Schedule/ dates are as given below:-**

- 10.1 The RFP Document can be obtained from the Office of **UTKARSH Society, Edusat Block, DIET Campus, Sector -2, Panchkula (Haryana)** on any working day before **24/10/2013 (till 05:00 PM)**. Alternatively, the RFP document can also be downloaded from the website <http://schooleducationharyana.gov.in>
- 10.2 'Pre Bid Meeting' will be held on **26/08/2013 at 11:00 AM** in the '**Conference Hall**' at **UTKARSH Society Edusat Block, DIET Campus, Sector-2, Panchkula (Haryana)**. If the meeting is not able to cover all the bidders on 26<sup>th</sup> the meeting will continue on 27<sup>th</sup> i.e. 27/08/2013.
- 10.3 Last date for the submission of bids is **25/10/2013 upto 03:00 PM**. Bidders are requested to submit their sealed bids for the "CAMC of Haryana Edusat HUB, TE & 250 SITs" in the Office of '**Administrative Officer, UTKARSH Society, Edusat Block, DIET Campus, Sector -2, Panchkula (Haryana)** on or before **25/10/2013 upto 03:00 PM**.
- 10.4 The Technical bids will be opened on **30/10/2013 (at 11:00 AM)** in the '**Conference Hall**' at **UTKARSH Society Edusat Block, DIET Campus, Sector-2, Panchkula (Haryana)**.
- 10.5 Financial bids of the 'successful bidders in Technical bids' will be opened. The date, time & venue of the opening of Financial Bids will be intimated later to the technically qualified bidders.
- 11.0 Penalty Clause:**
- 11.1 The Down Time is 2 (TWO) working days for the HUB & Teaching End. Bidder shall attend and repair the faults reported/lodged by the UTKARSH Society within 2 (TWO) working days from the date & time of log-in of the complaint. For each subsequent day of delay after 2 (Two) working days from the date of log-in of the complaint, 1 % of quarterly CAMC value per day will be recovered from the bill with ceiling of 20 % of total quarterly CAMC value of HUB and Teaching End after, which

UTKARSH Society shall be at liberty to cancel the contract. In case of cancelation of contract by UTKARSH Society, no payment shall be given to the Bidder for the rest of Quarter and PBG deposited by the bidder will be forfeited.

- 11.2 The Down time is 7 (Seven) working days for the SIT sites of network. Bidder shall attend and repair the faults reported/lodged by the 'Users & UTKARSH Society' within 7 (Seven) working days from the date & time of registration of the complaint. For each SIT site, any subsequent day of delay after 7 (Seven ) working days from the date of registration of the complaint, 0.5% of quarterly CAMC value per day will be recovered from the bill with ceiling of 5% of total quarterly CAMC value of SITs of network, after which UTKARSH Society shall be at liberty to cancel the contract. In case of cancelation of contract by UTKARSH Society, no payment shall be given to the Bidder for the rest of Quarter and PBG deposited by the bidder will be forfeited.

## **12.0 Escalation Matrix:-**

- 12.1 Bidder shall provide various level of contact information in the form of 'Escalation Matrix' as per Annexure-F for coordination, support, successful execution of the 'CAMC of HUB, TE & 250 SITs'.
- 12.2 The 'First Level of Support' shall be the 'Project Engineer' of the Bidder's Company/Firm to take care of day to day issues/Complaints relating to the 'CAMC of HUB, TE & 250 SITs'.
- 12.3 In case of the failure of 'First Level of Support' to provide necessary solution to UTKARSH Society, issue will be escalated to 'Second Level of Support'. 'Second Level of Support' shall be the 'Project Coordinator' of the Bidder's Company/Firm, who will ensure the 'Response & Solution' to the issues/complaints escalated to this level within 24 Hours. However, the penalty will remain applicable as mentioned in the Penalty Clause (at point no. 11.0) of the RFP Document.
- 12.4 In case of the failure of 'Second level of support' to provide necessary solution to UTKARSH Society, issue will be escalated to 'Top Level of support'. 'Top Level of support' shall be the 'Chairman/Executive Director / Managing Director' of the bidder's Company/firm, who will ensure the 'Response & Solution' to the issues/complaints escalated to this level within '12 Hours'. However, the penalty will remain applicable as mentioned in the Penalty Clause (at point no. 11.0) of the RFP Document.
- 12.5 All issues/complaints must be attended within stipulated period as defined in the RFP Document. If in case, the successful bidder fails to 'Respond & Resolve' the complaints as per the 'Escalation Matrix' then, in exceptional circumstances

UTKARSH Society, Panchkula reserves the right to get the work done from any other Company/Firms/Source/Agency. In that case, all expenses of repair will be deducted from the 'Payment of bills of the CAMC' of the successful bidder.

**13.0 Fall Clause:**

- 13.1 The prices charged for the CAMC services/equipments supplied under order by Bidder shall in no way exceed the lowest price at which the Bidder sell the CAMC services/equipments supplied or offer to sell CAMC services/equipments of identical description on similar terms and conditions to any person/Organization including the purchaser or any Department of the Central Govt. or any Deptt. of the State Govt. or any statutory undertaking of the Central or State Govt. as the case may be during the period till performance of the Work Order placed during the currency of the order/contract is completed.
- 13.2 If at any time during the said period Bidder reduce the rate or sale price, sell or offer to sell such services/Supplies to any person/Organization including the purchaser or any. Deptt. of Central Govt. or any Deptt. of State Govt. or any statutory undertaking of the central or State Govt as the case may be at a price, lower than the price chargeable under the Work Order/contract Bidder shall forthwith notify such reduction of price or offer to sell to the Society the CAMC services/supplies at the reduced price payable for the services/equipment supplied after the date of coming into force of such reduction.
- 13.3 Bidder shall furnish a certificate along with each bill or payment for CAMC Services/ supplies made against the Work Order/contract that, there has been no reduction in sale price of the CAMC services/supplies of description identical to the services/ equipments supplied to the Society under the Work Order/contract herein and such services/equipment have not been offered and sold by Bidder on similar terms and conditions to any person/Organization including the purchaser of any Deptt. of the Central Govt. or any Deptt. of the State Govt. or any statutory undertaking of the Central or State Govt. as the case may be upto the date of the bill/date of completion of CAMC services/supplies against the Work Order placed during the currency of the contract at a price lower than the price charged to the Society under the contract.

**14.0 Force Majeure:**

- 14.1 Notwithstanding the provisions of the RFP, Bidder shall not be liable for forfeiture of its performance security, liquidated damages or termination for default, if and to the extent that, its delay in performance or failure to perform its obligations under the contract is the result of an event of Force Majeure.



- 14.2 For the purposes of this Clause, 'Force Majeure' means an event beyond the control of the Bidder like acts of the Government of Haryana/UTKARSH Society either in its sovereign or contractual capacity, war or revolution, fire, floods, epidemics, quarantine restrictions and freight embargoes.
- 14.3 If a Force Majeure situation arises, Bidder shall promptly notify to the UTKARSH Society in writing of such a condition and the cause thereof. Unless otherwise directed by the UTKARSH Society in writing, Bidder shall continue to perform its obligations under the Work Order/contract as far as reasonably practical, and shall seek all reasonable alternative means for performance not prevented by the Force Majeure event.
- 14.4 The UTKARSH Society may terminate the Work Order/contract, by giving a written notice of minimum 15 days to Bidder, if as a result of Force Majeure, Bidder is unable to perform a material portion of the services for a period of more than 30 days.
- 15.0 Arbitration:**
- 15.1 All disputes, differences, claims and demands arising under or pursuant to or touching the 'RFP & Contract' shall be referred to the sole arbitrator (Sole arbitrator will be decided by UTKARSH Society, Panchkula).
- 15.2 This is notwithstanding the fact that the sole arbitrator may be connected in any manner with the official process of finalizing the Work Order/Contract. The award of the sole arbitrator shall be final and binding on both the parties under the provisions of the Arbitration and Conciliation Act, 1996 or by statutory modification re-enactment thereof for the time being in force. Such arbitration shall be held at Panchkula (Haryana).
- 15.3 All disputes are subject to Panchkula Jurisdiction only.
- 16.0 Termination of Contract:**
- 16.1 UTKARSH Society, Panchkula reserves the right to terminate the contract if the performance of the Bidder is found to be unsatisfactory during the duration of the contract by giving one month's notice in writing without any financial implications on UTKARSH Society,Panchkula.
- 17.0 Addition/Deletion Clause:**
- 17.1 UTKARSH Society, Panchkula reserves all the rights to add or delete any SITs during the duration of the contract. Payment for any addition of SITs will be made as Pro-rata basis.

- 17.2 UTKARSH Society, Panchkula also reserves all the rights of accepting the whole or any part of the RFP bids and the bidders shall be bound to perform the same at the quoted rates.
- 17.3 Evaluation of the financial bid will be done on the basis of total amount mentioned by the bidder on financial bids for 'CAMC'/'Technology upgradation & CAMC'. However, in case UTKARSH Society invokes its right to cancel whole or part of any item in the financial bid, evaluation of remaining items will be done on individual item basis.
- 18.0 Rights regarding cancellation of RFP, acceptance & rejection of any bid(s):**
- 18.1 UTKARSH Society, Panchkula reserves the right to accept any bid (s), and to annul the RFP process and reject all bids at any time prior to award of contract, without assigning reasons & without thereby incurring any liability to the affected bidder or bidders or any obligation to inform the affected bidder or bidders. UTKARSH Society, Panchkula reserves all the rights to cancel the partial or entire RFP process/bids without giving any reasons to any of the parties at any stage.
- 18.2 UTKARSH Society, Panchkula reserves the right to select any one option (i) CAMC with existing technology or (ii) CAMC with upgradation/new VSAT technology without giving any reason.

**Annexure – I (1 of 3)**

**List of Equipments of HUB (SIT & ROT) System, Teaching end & SIT for CAMC**

**List of Equipment & Subsystems of Ku-Band HUB (SIT & ROT) System for CAMC:-**

Sr. no.	Name of Equipment	Make	Model	Quantity
1.	Modulator (for SIT)	Viasat	DM 240 VS	One
2.	Modulator (for ROT)	Viasat	DVB S2 - NTC 2277	One
3.	Source Media Router IPE including OS & software	Viasat (Sky stream Networks)	SMR 25 V4.3.3	One
4.	GcUs	Viasat	Link Star	Four (Two in active use + Two as Cold standby)
5.	TDU	Viasat	Link Star	One
6.	Power Distribution units	Marway Power Systems	MPD 100 IEC	Four
7.	LNB	Viasat	NJR2837H	One
8.	Sun Server with OS & Viasat software	Sun Micro Systems	SunFire V 210	One
9.	Router	Cisco Systems	2800 Series 2851	One
10.	GPS & antenna (GPS 8 Satellite Synchronized Time & Frequency Standard	Brandwine Communications		One
11.	25 Watt BUC system (Ku band) with surge protector, L-Band Converter & IFL	Agilis	BUC 25 Watt L- Band Converter – AUC 28 series	One
12.	L band splitter (1:16)	ETL Systems		One
13.	AUPC +BDC	Jisnu communications Ltd.	JC-SC-UL 21 + JC SC BT 11	One
14.	LMS server with OS, TarinNet LMS software for 512 student end clients)	HP LMS Software – TrainNet (Robo Group)	Server CPU – HP Prolient ML110, Monitor HP 7540, KB & Mouse-HP	One
15.	Antivirus Server with OS, McAfee antivirus server & 512 student end clients	HP	Server CPU- Prolient ML350, Monitor 7540, KB & Mouse-HP	One
16.	NMS Computer System with OS & NMS software	Dell	Optiplex GX 280	One
17.	Multiplexer	Scopus Network Technologies	Codico RTM 3300	One
18.	Encoder	Scopus Network Technologies / Scopus video Network	Codico E-1000 (Two no's) & UE-9000 Universal Encoder (Two no's)	Four
19.	IRD Professional Receiver Decoder	Scopus Video Networks	Codico IRD-2600	One
20.	ADA VDA unit (with 04 Audio cards, 04 video cards & 02 supplies)	Leitch	FR684 AV	One
21.	Audio Spectrum Display	Wohler Technologies	LM30-2	One
22.	Monitoring Speaker (inbuilt amplifier)	Genelec	8030 A Bi amplified Monitoring system	Three
23.	HUB Antenna (3.8 meter)	Prodelin		One
24.	10 KVA UPS with boost up charger	Electronics & Controls Power Systems Pvt. Ltd.	4310	One
25.	Miscellaneous items (connecting wires, connectors, splitter, attenuators, internal batteries etc.)	As per equipments installation		

**Note:-** All equipments, servers, systems & sub subsystems are with necessary Operating Systems (OS), softwares & firmwares etc.

**Annexure – I (2 of 3)**

**Equipments & Subsystems of Teaching End (TE) for CAMC:-**

<b>Sr. no.</b>	<b>Name of Equipments</b>	<b>Make</b>	<b>Model</b>	<b>Quantity</b>
1.	TrainNet Teaching end Computer (with Nvidia Graphic card), Teaching end software, antivirus client	HP Teaching End Software-TrainNet (Robo Group)	CPU- Compaq DX6120 Monitor - HP 7540, KB & Mouse-HP	One
2.	Trainnet Video Server (with viewcast osprey 230 Video input card & graphic card), Trainnet Teaching end video server software, antivirus client	HP Teaching End Software-TrainNet (Robo Group)	CPU- Compaq DX6120 Monitor -HP 7540, KB & Mouse-HP	One
3.	Camera (HandyCam)	Sony	TRV 285 E	One
4.	Camera (PTZ)	Sony	EVI D70P	One
5.	Digital Audio Video mixer	Panasonic	AG MX 70	One
6.	Audio Mixer	Shure	SCM 410	One
7.	Wireless Mike	Beyerdynamic	Opus	One
8.	Lapel mike	Shure	PGX1 - PGX4	One
9.	Audio Amplifier System with Two Speakers	Bosch /Ahuja	Bosch – Plena LBD 1906/100 OR Ahuja - SCB 80EM	One
10.	2 KVA UPS with isolation transformer	Electronics & Controls Power Systems Pvt. Ltd.	Accenta	One
11.	Miscellaneous items (connecting wires, connectors etc.)	As per equipments installation		

**Note:-**

All equipments, servers, systems & sub subsystems are with necessary Operating Systems (OS), softwares & firmwares etc.

**Annexure – I (3 of 3)**

**Equipments & Subsystems at each Remote SIT Site for CAMC:-**

<b>Sr. No.</b>	<b>Name of Equipments</b>	<b>Make</b>	<b>Model</b>	<b>Quantity</b>
1.	Ku Band Link equipments (consisting of LNB, BUC, RCST & IFL)	Viasat	LNB- Viasat internal Reference PLL KU band, BUC- 2 Watt, RCST- Viasat Linkstar	One each
2.	Antenna (Ku band, 1.2 meters ) NP type with feed assembly set	Comsat /Prodeline		One
3.	Student End Computer set (with View cast osprey 230/300 Audio Video input card & Nvidia GE 6200 graphic card), Trainnet Student End Software & antivirus client.	HP Student End Software-TrainNet (Robo Group)	Compaq DC 7600 OR DX6120 Monitor -HP 7540, KB & Mouse-HP	One
4.	Projector	HP/ Benq	HP- VP 6310 OR Benq -MP611	One
5.	Audio Amplifier System with Two Speakers	Bosch /Ahuja	Bosch – Plena LBD 1906/100 OR Ahuja - SCB 80EM	One
6.	Camera Set	Sony	TRV 285 E	One
7.	Wireless Mike	Beyerdynamic OR Mipro	Beyerdynamic - Opus OR Mipro-MR801	One
8.	1 KVA UPS (with boost up charger & PMD)	Electronics & Controls Power Systems Pvt. Ltd.	Accenta	One
9.	Miscellaneous (connecting wires, connectors, internal batteries, extension board Ceiling mount of Projector etc.)	As per equipments installation		

**Note:-**

1. All equipments, servers, systems & sub subsystems are with necessary Operating Systems (OS), softwares & firmwares etc.
2. There are two types of equipment configurations of Remote SITs having different make & models of Equipments Like Projector (HP **OR** Benq ), Audio Amplifier (Bosch **OR** Ahuja ), Computer (Compaq DC 7600 **OR** DX6120 ) , Wireless mike (Beyerdynamic **OR** Mipro ), Antenna (Comsat **OR** Prodeline).

**Annexure - II (1 of 2)**

**Schematic Block Diagram of the existing HUB, TE & SITs of Haryana Edusat Network**

**Schematic Block Diagram of Ku Band HUB (SIT & ROT) System:-**

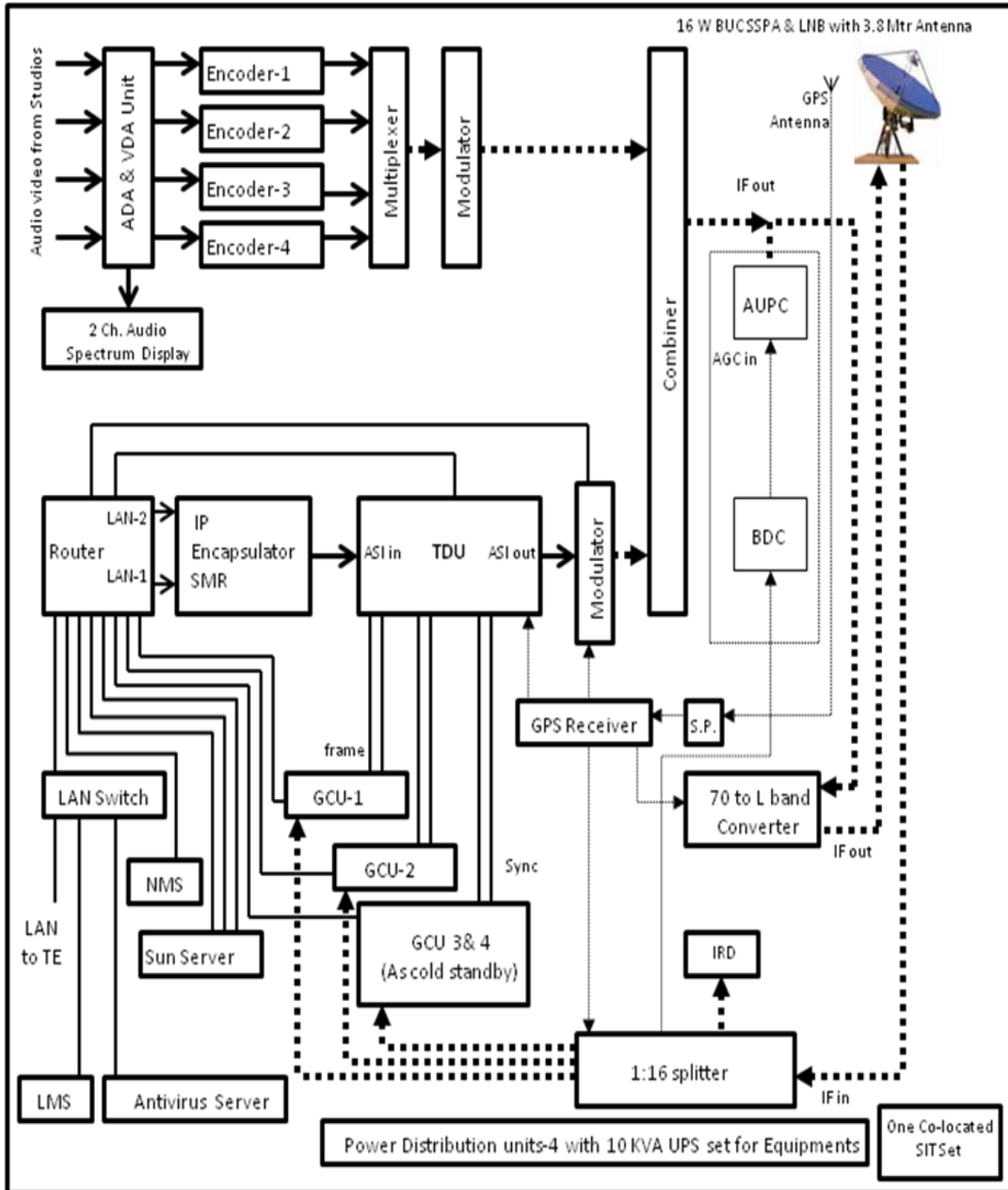

Annexure - II (2 of 2)

Schematic Block Diagram of the existing HUB, TE & SITs of Haryana Edusat Network

Schematic Block Diagram of Teaching End (TE) & SITs:-

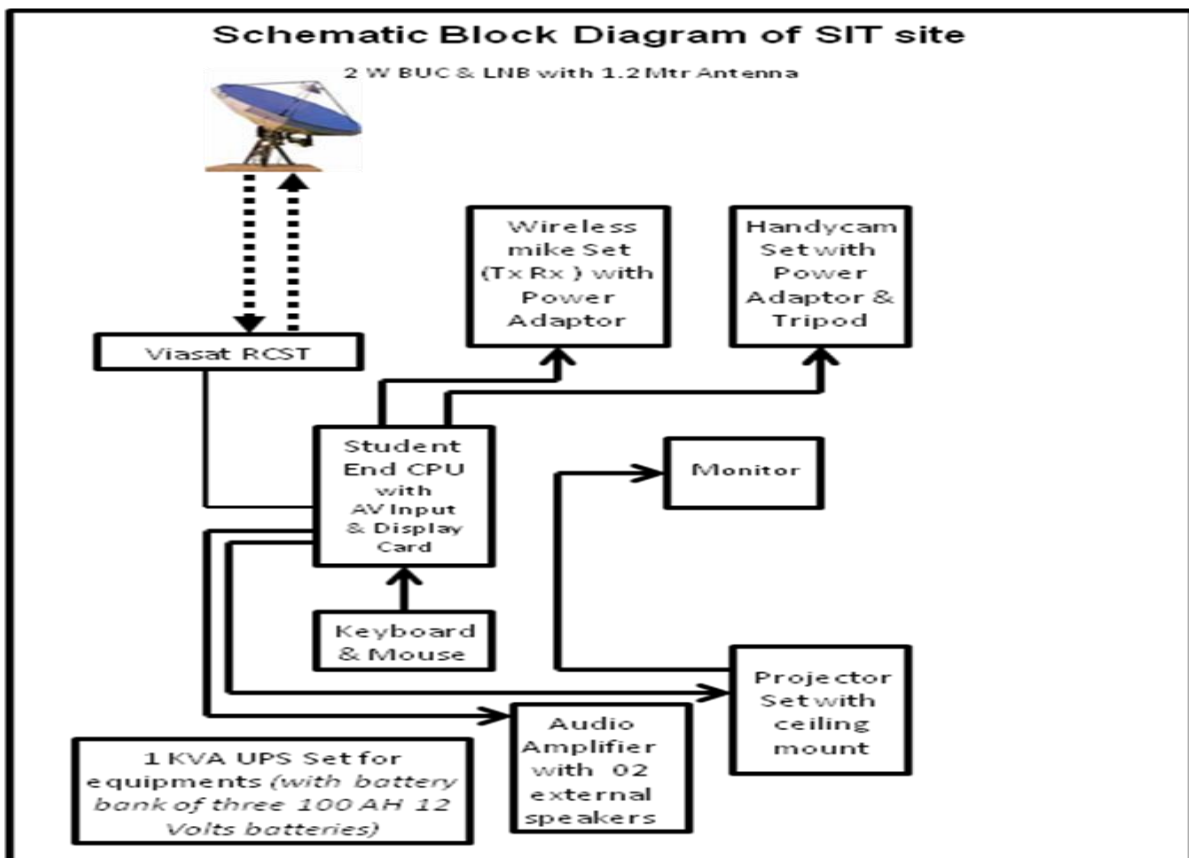
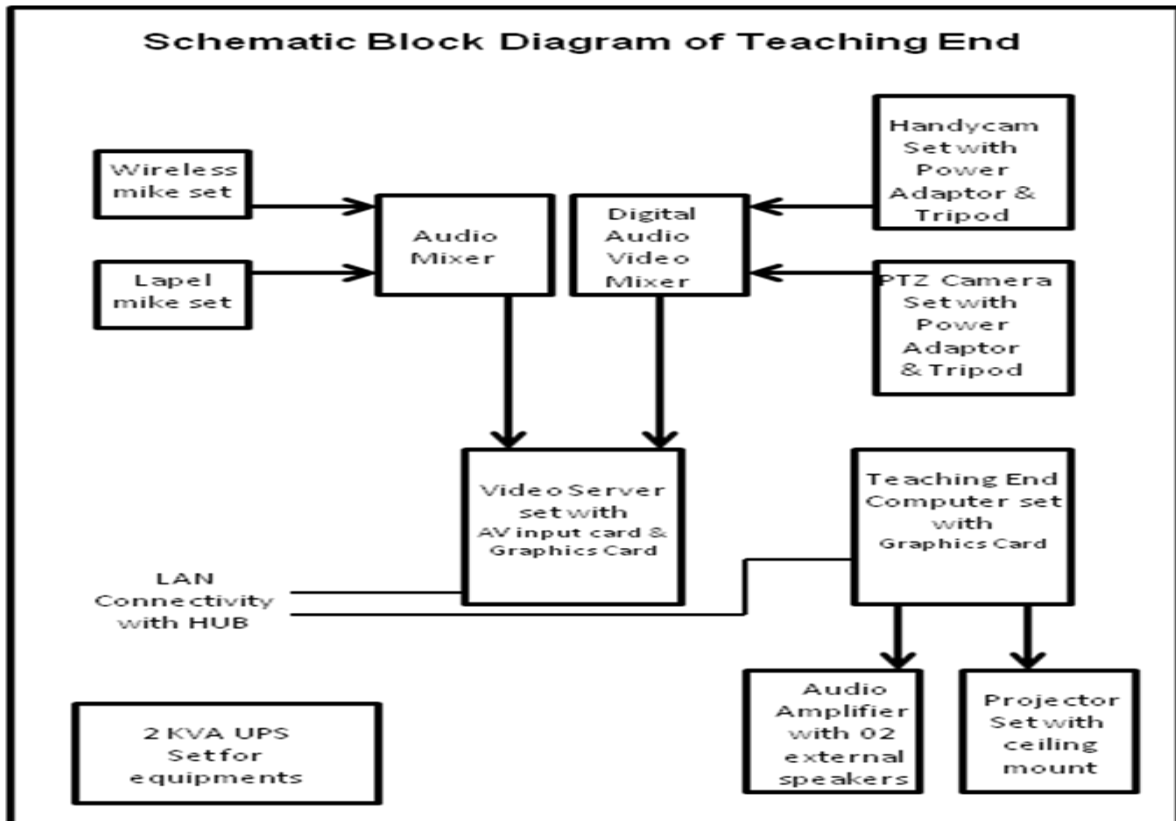

## **Annexure - III**

### **Addresses & Contact Details of Coordinators**

#### **(A) Haryana Edusat Network Coordinator details:**

- (1) Administrative Officer,  
UTKARSH Society, Haryana Edusat Network,  
Edusat Block, DIET Campus, Sector-2,  
Panchkula (Haryana)  
Ph.: 0172-2587710, Fax: 0172-2587403
  
- (2) Manager (Technical),  
UTKARSH Society, Haryana Edusat Network,  
Edusat Block, DIET Campus, Sector-2,  
Panchkula (Haryana)  
Ph.: 0172-2587710, Fax: 0172-2587403

#### **(B) Hub & Teaching end site details:**

- (1) UTKARSH Society, Haryana Edusat Network,  
Edusat Block, DIET Campus, Sector-2,  
Panchkula (Haryana)  
Ph.: 0172-2587710, Fax: 0172-2587403



**Annexure – A**

**FINANCIAL BID**

**Financial bid for the CAMC of HUB (SIT & ROT) System, Teaching End (TE), 250 SITs 'WITH EXISTING TECHNOLOGY' for Two Years (1<sup>st</sup> & 2<sup>nd</sup> Year combined)**

<b>Sr. No</b>	<b>Description</b>	<b>Per unit</b>	<b>Quantity</b>	<b>Amount (in Rs.)</b> inclusive of all types of taxes, custom duties, duties, transportation charges etc.
1.	<b>CAMC</b> of Ku-Band HUB (SIT & ROT) System including TrainNet LMS Server, Antivirus Server and one co-located SIT site	1	1	(In figures):  (In words):
2.	<b>CAMC</b> of Teaching End (TE)	1	1	(In figures):  (In words):
3.	<b>CAMC</b> of Satellite Interactive Terminals	1	250	(In figures):  (In words):
<b>Total Amount for the CAMC (Sr. No. 1 to 3 above)</b>				(In figures):  (In words):
4.	Site visit charges for the rectification of SIT Site (if faulty).	Per SIT site		(In figures):  (In words):
5.	*Shifting of SIT in the same location from one building to another (same campus) including site visit charges	1		(In figures):  (In words):
6.	*Shifting of SIT from one location to another within same state (Haryana) including site visit charges	1		(In figures):  (In words):

- Note:** - (I) The evaluation for the 'Sr. No's 1 to 3 mentioned above' will be done on the basis of total amount of the Sr. No. 1,2 & 3 above. However, in case UTKARSH Society invokes its right to cancel whole or part of any item mentioned at Sr. No. 1 to 3, evaluation of remaining items will be done on individual item basis.
- (II) All Systems, Equipments, Sub-systems Hardware, OS, Software, Firmware etc. are included in CAMC.
- (III) HUB (SIT&ROT), TE installed at UTKARSH Society, Panchkula (Haryana) and SITs installed at various locations throughout Haryana State.
- (IV) \* Shifting means dismantling the SIT equipment, transporting it to decided location and re installation & commissioning at new location.

Name of the Company/Firm:.....

Address for Correspondence:.....

.....

Phone No: ..... E-mail address:.....

Date: .....

Full signature of the Bidder along with Seal:-

**Annexure – B**

**FINANCIAL BID**

**Financial bid for the CAMC of HUB (SIT & ROT) System, Teaching End (TE), 250 SITs 'WITH EXISTING TECHNOLOGY' for 'Third' & 'Fourth' Years**

Sr. No	Description	Per Unit	Quantity	Amount (in Rs.) inclusive of all types of taxes, custom duties, duties, transportation charges etc.	
				Amount for Third Year	Amount for Fourth Year
1.	<b>CAMC</b> of Ku-Band HUB (SIT & ROT) System including TrainNet LMS Server, Antivirus Server and one co-located SIT site	1	1		
2.	<b>CAMC</b> of Teaching End (TE)	1	1		
3.	<b>CAMC</b> of Satellite Interactive Terminals	1	250		
<b>Total Amount for the CAMC (Sr. No. 1 to 3 above)</b>					
4.	Site visit charges for the rectification of SIT Site (if faulty).	Per SIT site			
5.	*Shifting of SIT in the same location from one building to another (same campus) including site visit charges	1			
6.	*Shifting of SIT from one location to another within same state (Haryana) including site visit charges	1			

- Note:** - (I) The evaluation for the 'Sr. No's 1 to 3 mentioned above' will be done on the basis of total amount of the Sr. No. 1,2 & 3 above. However, in case UTKARSH Society invokes its right to cancel whole or part of any item mentioned at Sr. No. 1 to 3, evaluation of remaining items will be done on individual item basis.
- (II) All Systems, Equipments, Sub-systems Hardware, OS, Software, Firmware etc. are included in CAMC.
- (III) HUB (SIT&ROT), TE installed at UTKARSH Society, Panchkula (Haryana) and SITs installed at various locations throughout Haryana State.
- (IV) \* Shifting means dismantling the SIT equipment, transporting it to decided location and re installation & commissioning at new location.

Name of the Company/Firm:.....

Address for Correspondence:.....

.....

Phone No: ..... E-mail address:.....

Date: .....

Full signature of the Bidder along with Seal:-

**Annexure – C (1 of 3) (FINANCIAL BID)**

**Cost of Spares/Subsystems of HUB (SIT & ROT) System, TE & 250 SITs**

**Spares/Subsystems of KU Band HUB (SIT & ROT) System: -**

*(Table 1 of 2)*

<b>Sr. No.</b>	<b>Name of Equipment</b>	<b>Make / Model No.</b>	<b>Amount per unit (in Rs.)</b> inclusive of all types of taxes, custom duties, duties, transportation charges etc.
1.	Modulator (for SIT)		
2.	Modulator (for ROT)		
3.	Source Media Router IPE including OS & Software		
4.	GCU		
5.	TDU		
6.	Power Distribution unit		
7.	LNB		
8.	Sun Server Hardware including OS & Viasat software		
9.	Router		
10.	GPS Receiver set with antenna (GPS 8 Satellite Synchronized Time & Frequency Standard)		
11.	3.8 meters Ku Band Antenna Set (with reflector, feed, NP mount & assembly etc.)		
12.	25 Watt BUC system (Ku band) with surge protector L-Band Converter & IFL		
13.	L band splitter (1:16)		
14.	AUPC + BDC		
15.	Hardware/Server for TrainNet LMS with OS, Monitor, Keyboard & Mouse		
16.	Trainnet LMS Server Software for HUB end & TE		
17.	Trainnet LMS Software for Client/Student end		
18.	Hardware/Server for Antivirus with OS, Monitor, Keyboard & Mouse		
19.	Antivirus Server software		
20.	Client of Antivirus software		
21.	NMS Computer (with OS, Software, Monitor, Keyboard & Mouse)		
22.	Multiplexer		
23.	Encoder		
24.	IRD Professional Receiver Decoder		
25.	ADA VDA unit (with 04 Audio cards, 04 video cards & 02 supplies)		

*Table Continued on next Page:-*

Date:- .....

Full signature of the Bidder along with Seal:-

**Cost of Spares/Subsystems of HUB (SIT & ROT) System, TE & 250 SITs**

**Spares/Subsystems of KU Band HUB (SIT & ROT) System: -**

*(Table 2 of 2)*

<b>Sr. No.</b>	<b>Name of Equipment</b>	<b>Make / Model No.</b>	<b>Amount per unit (in Rs.)</b> inclusive of all types of taxes, custom duties, duties, transportation charges etc.
26.	ADA Card		
27.	VDA Card		
28.	Audio Spectrum Display		
29.	Monitoring Speaker (inbuilt amplifier)		
30.	HUB Antenna Set (3.8 meter)		
31.	10 KVA UPS with boost up charger		
32.	Miscellaneous items (connecting wires, connectors, splitter, attenuators, internal batteries etc.)		

1. Amount shall inclusive of all necessary software, installation, commissioning & integration etc. to ensure the functionality of spares/equipments.
2. All the equipment to be supplied must be fully compatible & functional with existing equipment setup of Haryana Edusat Network.

Name of the Company/Firm:.....

Address for Correspondence:.....

.....

Phone No: ..... E-mail address:.....

Date: .....

Full signature of the Bidder along with Seal:-

**Cost of Spares/Subsystems of HUB (SIT & ROT) System, TE & 250 SITs****Spares/subsystems of Teaching End (TE):-**

<b>Sr. No.</b>	<b>Name of Equipment</b>	<b>Make / Model No.</b>	<b>Amount per unit (in Rs.)</b> inclusive of all types of taxes, custom duties, duties, transportation charges etc.
1.	TrainNet Teaching End Computer with OS, TE software, Graphic card, Monitor, Keyboard & Mouse.		
2.	TrainNet Video Server with OS, Video server software, Audio Video input card, Graphic card, Monitor, Keyboard & Mouse.		
3.	Camera (HandyCam) set		
4.	Camera (PTZ) set		
5.	Digital Audio Video mixer		
6.	Audio Mixer		
7.	Wireless Mike set		
8.	Lapel mike set		
9.	Audio Amplifier System with Two Speakers		
10.	2 KVA UPS with isolation transformer & charger		
11.	Miscellaneous items (connecting wires, connectors, etc.)		

1. Amount shall inclusive of all necessary software, installation, commissioning & integration etc. to ensure the functionality of spares/equipments.
2. All the equipment to be supplied must be fully compatible & functional with existing equipment setup of Haryana Edusat Network.

Name of the Company/Firm:.....

Address for Correspondence:.....

.....

Phone No: ..... E-mail address:.....

Date: .....

Full signature of the Bidder along with Seal:-

## Cost of Spares/Subsystems of HUB (SIT &amp; ROT) System, TE &amp; 250 SITs

## Spares/subsystems of Satellite Interactive Terminal (SIT):

(Table 1 of 2)

Sr. No.	Name of Equipment	Make / Model No.	Amount per unit (in Rs.) inclusive of all types of taxes, custom duties, duties, transportation charges etc.
1	1.2 meters Ku-Band Antenna Set (with reflector, feed, NP mount & assembly etc.)		
2.a	RCST (IDU) with necessary interface cables		
2.b	Ku-band 2w-BUC		
2.c	LNB Internal ref.PLL type		
3	1 KVA UPS, its accessories like boost up charger & PMD etc. (without batteries)		
4.a	Student end CPU with OS		
4.b	Monitor		
4.c	Mouse		
4.d	Key Board		
5.a	Audio Video Input card with Connectors		
5.b	Video connecting cable for Audio Video Input Card (Camera to AV I/P card)		
5.c	XLR Audio Cable with connector (Wireless mike base to AV I/P card)		
6	Graphics card		
7	TrainNet client software (Downloaded from HUB) per client		
8.a	Video Handycam		
8.b	AV connecting wire (camera to card)		
8.c	Tripod for Handycam		
8.d	Power Adaptor of Handycam		
9.a	Audio Amplifier		
9.b	Speakers (2 no's) for audio amplifier		
9.c	Audio wire (CPU to audio amplifier)		
10.a	Wireless Microphone Transmitter		
10.b	Wireless Microphone Receiver Base		
10.c	Power adaptor of wireless mike Receiver		
11.a	Projector		
11.b	Screen of Projector		
11.c	Ceiling mount kit for projector		
11.d	VGA Cable (CPU to Projector / Projector to Monitor)		
12.	Wooden Cabinet for housing indoor equipments		

Table Continued on next Page:-

Date:- .....

Full signature of the Bidder along with Seal:-

Name &amp; Signature of the Bidder along with Seal

## Cost of Spares/Subsystems of HUB (SIT &amp; ROT) System, TE &amp; 250 SITs

## Spares/subsystems of Satellite Interactive Terminal (SIT):

(Table 2 of 2)

Sr. No.	Name of Equipment	Make / Model No.	Amount per unit (in Rs.) inclusive of all types of taxes, custom duties, duties, transportation charges etc.
13.a	IFL RG-11 Cable (per meter)		
13.b	Connector for IFL RG-11 cable		
14	Lamp for existing Benq projectors		
15	Lamp for existing HP projectors		
16	Miscellaneous (connecting wires, connectors, internal batteries, Extension board etc.		

1. Amount shall inclusive of all necessary software, installation, commissioning & integration etc. to ensure the functionality of spares/equipments.
2. All the equipment to be supplied must be fully compatible & functional with existing equipment setup of Haryana Edusat Network.

Name of the Company/Firm:.....

Address for Correspondence:.....

.....

Phone No: ..... E-mail address:.....

Date: .....

Full signature of the Bidder along with Seal:-

**Annexure – D  
FINANCIAL BID**

Financial bid for the “**TECHNOLOGY UPGRADATION of existing HUB (SIT & ROT), Teaching End (TE), 250 SITs** (including supply of necessary equipments in buy back of replaced spares with three years warrantee, installation, commissioning & integration of supplied spares

**AND**

**CAMC of HUB (SIT & ROT), Teaching End (TE), 250 SITs for ‘Two Years’** (1<sup>st</sup> & 2<sup>nd</sup> Year combined) after the “**Technology Upgradation**”.

Sr. No.	Description	Per Unit	Quantity	Amount (in Rs.) inclusive of all types of taxes, custom duties, duties, transportation charges etc.
1.	<b>Technology Upgradation</b> of Ku Band HUB(SIT & ROT) System, LMS server and one co-located SIT site (Only equipment which are supplied due to change in VSAT technology)	1	1	(In figures): (In words):
2.	<b>Technology Upgradation</b> of Teaching End (Only equipment which are supplied due to change in VSAT technology)	1	1	(In figures): (In words):
3.	<b>Technology Upgradation</b> of Satellite Interactive Terminals of Haryana Edusat Network. (Only equipment which are supplied due to change in VSAT technology)	1	250	(In figures): (In words):
<b>(A) Total Amount for the Technology Upgradation (Sr. No. 1 to 3 above)</b>				(In figures): (In words):
4.	<b>CAMC</b> of rest of equipments of Ku-Band HUB (SIT & ROT) System including LMS Server, Antivirus Server and one co-located SIT site (after technology upgradation)	1	1	(In figures): (In words):
5.	<b>CAMC</b> of rest of equipments of Teaching End (after technology upgradation)	1	1	(In figures): (In words):
6.	<b>CAMC</b> of rest of equipments of Satellite Interactive Terminals (after technology upgradation) of Haryana Edusat Network	1	250	(In figures): (In words):
<b>(B) Total Amount for the CAMC after Technology Upgradation (Sr. No. 4 to 6 above)</b>				(In figures): (In words):
<b>(A+B) Total Amount for the Technology Upgradation and CAMC (Sr. No. 1 to 6 above)</b>				(In figures): (In words):
7.	Site visit charges for the rectification of SIT Site ( <i>if faulty</i> ).	Per SIT site		(In figures): (In words):
8.	*Shifting of SIT in the same location from one building to another (same campus) including site visit charges	1		(In figures): (In words):
9.	*Shifting of SIT from one location to another within same state (Haryana) including site visit charges	1		(In figures): (In words):

**Note:** - (I) The evaluation for the ‘Sr. No’s 1 to 6 mentioned above’ will be done on the basis of total amount of the Sr. No. 1,2,3,4,5 & 6 above. However, in case UTKARSH Society invokes its right to cancel whole or part of any item mentioned at Sr. No. 1 to 6, evaluation of remaining items will be done on individual item basis.

(II) All Systems, Equipments, Sub-systems Hardware, OS, Software, Firmware etc. are included in CAMC.

(III) HUB (SIT&ROT), TE installed at UTKARSH Society, Panchkula (Haryana) and SITs installed at various locations throughout Haryana State.

(IV) \* Shifting means dismantling the SIT equipment, transporting it to decided location and re installation & commissioning at new location.

Name of the Company/Firm:.....

Address for Correspondence:.....

Phone No.: ..... E-mail address:.....

Date: .....

Full signature of the Bidder along with Seal:-

Name & Signature of the Bidder along with Seal



**Annexure – E**

**FINANCIAL BID**

**Financial bid for the CAMC of HUB (SIT & ROT) System, Teaching End (TE), 250 SITs 'AFTER TECHNOLOGY UPGRADATION' for 'Third' & 'Fourth' Years**

Sr. No	Description	Quantity	Amount (in Rs.) inclusive of all types of taxes, custom duties, duties, transportation charges etc.	
			Amount for Third Year	Amount for Fourth Year
1.	<b>CAMC</b> of Ku-Band HUB (SIT & ROT) System including TrainNet LMS Server, Antivirus Server and one co-located SIT site	1		
2.	<b>CAMC</b> of Teaching End (TE)	1		
3.	<b>CAMC</b> of Satellite Interactive Terminals	250		
<b>Total Amount for the CAMC (Sr. No. 1 to 3 above)</b>				
4.	Site visit charges for the rectification of SIT Site (if faulty).	Per SIT site		
5.	*Shifting of SIT in the same location from one building to another (same campus) including site visit charges	1		
6.	*Shifting of SIT from one location to another within same state (Haryana) including site visit charges	1		

**Note:** - (I) The evaluation for the 'Sr. No's 1 to 3 mentioned above' will be done on the basis of total amount of the Sr. No. 1,2 & 3 above. However, in case UTKARSH Society invokes its right to cancel whole or part of any item mentioned at Sr. No. 1 to 3, evaluation of remaining items will be done on individual item basis.

(IV) All Systems, Equipments, Sub-systems Hardware, OS, Software, Firmware etc. are included in CAMC.

(V) HUB (SIT&ROT), TE installed at UTKARSH Society, Panchkula (Haryana) and SITs installed at various locations throughout Haryana State.

(IV) \* Shifting means dismantling the SIT equipment, transporting it to decided location and re installation & commissioning at new location.

Name of the Company/Firm:.....

Address for Correspondence:.....

.....

Phone No: ..... E-mail address:.....

Date: .....

Full signature of the Bidder along with Seal:-

**ANNEXURE-F**

**ESCALATION MATRIX**

Escalation Matrix for the issues related to “CAMC of HUB, TE & 250 SITs”.

<b>Sr. No.</b>	<b>Description</b>	<b>Contact Details</b>
1.	<p align="center"><b>First Level of support</b></p> <p>(‘Project Engineer’ for the issues related to the “CAMC of HUB,TE &amp; 250 SITs”)</p>	Name: ..... Full Office Address:-..... ..... Mobile Phone Number:-..... Phone No..... FAX: ..... Email Address:
2.	<p align="center"><b>Second Level of Support</b></p> <p>If ‘Response &amp; Solution’ not received from First Level. The ‘Response &amp; Solution’ time of Second level of support is 24 Hours.</p> <p>(Project Coordinator for the issues related to the “CAMC of HUB,TE &amp; 250 SITs”).</p>	Name: ..... Full Office Address:-..... ..... Mobile Phone Number:-..... Phone No..... FAX: ..... Email Address:
3.	<p align="center"><b>Top Level of Support</b></p> <p>If ‘Response &amp; Solution’ not received from Second Level. The ‘Response &amp; Solution’ time of ‘Top Level of Support’ is 12 Hours.</p> <p>(Chairman/Executive Director / Managing Director of the Bidder’s Company/Firm” for the issues related to the “CAMC of HUB,TE &amp; 250 SITs”)</p>	Name: ..... Full Office Address:-..... ..... Mobile Phone Number:-..... Phone No..... FAX: ..... Email Address:

(Bidder shall informed to UTKARSH Society, Panchkula in case of any change in Designation, substitution, Contact details etc.

Name of the Company/Firm:.....

Address for Correspondence:.....

Phone No: ..... E-mail address:.....

Date: .....

Full signature of the Bidder along with Seal:-