

**REGD. POST****SUPPLY ORDER**

From

The Director General, Supplies & Disposals, Haryana,  
Bays No. 3-6, (2<sup>nd</sup> Floor), Sector-02, Panchkula  
E-mail: [supplies@hry.nic.in](mailto:supplies@hry.nic.in)

To

M/s Envea India Private Limited,  
D16 3 AND 4 TTC Industrial Area,  
MIDC TurbheNavi Mumbai-400705

E-mail: [service.india@environnement-sa.com](mailto:service.india@environnement-sa.com)

Memo No.141/HR/E-5/2025-26/  
Dated Panchkula the:-

**Subject:-** Renewal of Operation and Maintenance Service for Continuous Ambient Air Quality Stations at 03 locations required by Haryana State Pollution Control Board (HSPCB), Haryana.

\*\*\*\*\*

With reference to offer/Bid ID No.1346041 dated 10.10.2025 and your letter No. nil dated 24.03.2026, this office acceptance letter No. 1260 dated 22.04.2026 & your letter No. Nil dated 22.05.2026, on the subject noted above.

2. I enclose herewith an agreement form in duplicate and request that the agreement may be executed on a non-judicial stamp paper of Rs.15/- signed and return the same to this office within 10 days from the date of issue of this letter. One copy of the agreement will be sent to you duly executed on behalf of Governor of Haryana for your record. You may kindly send power of attorney in favour of the person/persons who is/ are authorized to signed the agreement together with/their specimen signature duly attested by a Magistrate or Oath Commissioner or Resolution of the firm authorizing the persons to sign the documents on behalf of the firm.
3. The Copy the supply order for taking over the charge of Operation and Maintenance Service for Continuous Ambient Air Quality Stations at 03 locations required by Haryana State Pollution Control Board (HSPCB), Haryana as per terms & conditions of DNIT effective from **01.06.2026 to 31.05.2031** & for payment, the bill of the cost/services in triplicate be sent to the Member Secretary, Haryana State Pollution Control Board, C-11, Sector-06, Panchkula under intimation to this office. The details of the supply order are as under:-

Sr. No.	Name of firms	Qty. (In Nos.)	Rates (In Rs.) per CAAQMS Station (Exclusive of GST) for 5 years and other terms & conditions shall be as per the DNIT.
1	M/s Envea India Private Limited, Mumbai	03 Nos. CAAQMS	57,50,000/- (Excluding Electricity Charges)

The digital data is displayed on real time basis through digital CAAQMS at each city of location. The details of the locations are as under:-

Sr. No.	District	CAAQMS Address
1.	Rohtak	Maharishi Dayanand University (MDU), Gate No.-2 (Ground Floor), Rohtak ,Haryana
2.	Panchkula	HSPCB, C-11, Sector -6, Panchkula
3.	Gurugram	HSPCB, 1ST FLOOR, Vikas Sadan, Gurgaon, Haryana

The scope of work & General conditions of contract are available at Annexure-A, technical specifications at Annexure-B.

4. SCHEDULE "B":- One copy of the Schedule "B" i.e. conditions of contract applicable is sent herewith duly signed on behalf of Governor of Haryana.

In case of non compliance or any breach of this Operation and Maintenance Service for Continuous Ambient Air Quality Stations for 5 years penal action would be taken.

Other terms & conditions will be as per NIT.

Encls.a/a

Executive Engineer  
Supplies & Disposals, Haryana  
For & On behalf of Governor of Haryana  
Dated :

Endst.No. 141/HR/E-5/2025-26/

A copy of the above is forwarded to The Member Secretary, Haryana State Pollution Control Board, C-11, Sector-6, Panchkula for information and necessary action. Payment may please made to the firm strictly as per the payment terms of DNIT.

Executive Engineer  
For Director General, Supplies & Disposals, Haryana.  
Dated : 26-05-26.

Endst.No. 141/HR/E-5/2025-26/ 3/6.

A copy is forwarded to the following for information and necessary action:-

1. The Accountant General (Audit) Haryana, Sector-33, Chandigarh.
2. The Excise & Taxation Commissioner, Mumbai.
3. St. Section.
4. Programmer O/o DGS&D, Haryana.
5. Department Processing Charges, O/o DGS&D, Haryana.

Executive Engineer  
For Director General, Supplies & Disposals, Haryana.

**VOLUME – I**

**SECTION II**

**SCOPE OF WORKS**

## **1.0 DETAILS OF PROJECT STRUCTURE**

The HSPCB has set up CAAQMS at 3 locations in the state of Haryana. The digital data is displayed on real time basis through digital CAAQMS at each city of location. Now it has been decided to renew its O&M.

- (a) Successful Bidder would be awarded the project/work under a Service (O&M) Agreement, which would entail of each CAAQMS:

1. Operation and Maintenance of 3 CAAQMS for a period of 5 years.

## **2.0 SCOPE OF WORK**

The Scope of Works under the package shall include:

- A) Operation & Maintenance of Continuous Ambient Air Monitoring Stations for a period of five (5) years, from the date of contract, which can be extended at the mutually agreed rates and terms and conditions.

Other services involved with performance of the Works are specified in General and Special Conditions of Contract of bid document.

## **3.0 MINIMUM TECHNICAL SPECIFICATIONS**

The minimum technical specification requirements for O&M of CAAQMS are given in Volume - II (Technical Specifications) of bid document. However, the actual technical proposal can have higher or better technical performance parameters and the minimum specifications proposed should not be taken as a constraint on the upper side. The technical specifications given in Volume - II (Technical Specifications) of bid documents are descriptive and Selection Committee can consider technical proposals having similar specifications. The specifications of CAAQMS are at Annexure-A.

## **4.0 DESIRED OUTPUT FOR O&M SERVICES CAAQMS**

The bidder must provide specified data of CAAQMS.

## **5.0 GENERAL GUIDELINES**

5.1 Working Hours: The site for CAAQMS operation should be manned by the employees of the Successful Bidder for 24 hours a day.

5.2 Insurance: Successful Bidder would bear the cost of insuring the equipment (Comprehensive) and facilities against any theft, fire and other applicable provisions during tenure of contract period including O&M with a copy to HSPCB of an appropriate amount.

The successful bidder shall maintain platform pillars etc. as required and shall also arrange electric and telephone connection modems etc. required for the smooth Operation of the station. The necessary documentation shall be provided by the concerned HSPCB / local authority of the board.

## **6.0 LOCATION**

3 locations of CAAQMS are given as above.

## **7.0 SUPPLY OF EQUIPMENT**

Equipment already installed

## **8.0 INSTALLATION OF EQUIPMENT**

Equipment already installed

## **9.0 INSPECTION AND TEST**

### **9.1 Unpacking Inspection**

The Contractor shall inspect the Site.

### **9.2 Performance Test**

Omitted.

## **10.0 Provision of Training**

Omitted.

## **11. OPERATION & MAINTENANCE OF CAAQMS**

The Contractor's responsibilities shall include without limitations the following works to be carried out for Air Monitoring Stations installed under this Contract during the Operation & Maintenance of the stations:

- a) Operation and Maintenance of all the commissioned equipments and amenities as supplied by HSPCB under the Contract including services during forced and planned outages and overhauls.
- b) The Contractor shall take over all the CAAQMS (including all equipment) for O&M after execution of Indemnity Bond as per format.
- c) The Contractor shall provide to the owner a monthly summary of all operation and maintenance activities performed by the contractor during each month.
- d) Operation and Maintenance Obligations:

In implementing its obligations to operate and maintain the facility under this Contract, the Contractor shall:

- i) Undertake comprehensive maintenance including i.e. schedule and breakdown maintenance & repair at site and keep
- ii) Board Informed regarding status of equipments and display daily data.
- iii) Obtain permission from the owner and inform the O&M for any assistance for which equipment is required to be sent to the works. Contractor shall arrange substitute equipment to keep CAAQMS operational.
- iv) Take reasonable action to assure that the Personnel deployed to check/monitor CAAQMS and any subcontractors and agents are provided with a work place in compliance with applicable Law.
- v) Keep the CAAQMS clean, well maintained and in good working condition.
- vi) Security: It is the duty of the Contractor to secure the movable, immovable and other properties of the Owner at the CAAQMS. The Contractor shall

indemnify the loss caused to the Owner on account of any damage, loss or theft caused to the property of the Owner.

- vii) Scheduled Maintenance: Unless Owner and Contractor mutually agree otherwise, perform all required Scheduled maintenance for all equipment, auxiliaries etc., in accordance with the O&M specifications.
  - viii) Unscheduled Maintenance: Perform all Unscheduled Maintenance and repairs for all equipment, auxiliaries etc. within (24) hours of the occurrence of the event requiring Unscheduled Maintenance, the operator shall provide the Owner with detailed written information on nature of the repair or replacement to be carried out, estimated down time and other necessary details as required.
  - ix) The Contractor shall source all the spares required for maintenance & repairs of the installed equipment.
- e) The Operator shall not:
- i) Make any modifications as to CAAQMS, other than in an Emergency, without the prior written approval of the Owner, or Dispose off any assets, settle law-suits or engage in transactions relating thereto on the Owner's behalf without the prior written approval of the Owner.
  - ii) The Contractor shall purchase spare parts, materials, supplies and other consumable items, and maintain an inventory thereof, for the CAAQMS. All such material supplied and other items shall be the property of the Contractor.
  - iii) The Contractor shall review all applicable Laws and initiate and maintain such prosecution, procedures and operating plans relating to operation of the CAAQMS as are necessary to comply therewith or assist the owner in complying therewith as the case may be.
  - iv) The Contractor shall ensure the display of data of the CAAQMS as per the laid out standards in the operating manual of the equipment and display data for ambient air on daily basis in the suggested format. The monthly reporting formats are attached as Annexure x1 to x2.
  - v) The CAAQMS have to be in operation for a minimum of 90% of the days in a year, 24 hours a day, and should not be inoperable for more than 7 days at a stretch failing which a penalty of Rs. 5000 per day from the date of non-
    - A. operation of CAAQMS shall be levied.
    - B. Display data for operation of the equipment on daily basis in suggested output formats given in the bid document.
    - C. The Contractor shall ensure accuracy of the data display.
    - D. The contractor shall ensure displaying the data after periodic re-calibration of all the equipment as per manufacturer's instructions and maintain "Protocol Calibration".

Owner (HSPCB) shall arrange for the following and Contractor shall guide and assist the Owner:

- a) The Owner shall pay O&M charges to the Contractor at the end of each quarter after submission of validated data & report by the Contractor, in accordance with the payment terms detailed in Special Conditions of Contract.
- b) Owner shall pay all fees including Service Tax, etc., imposed upon Owner by

the Applicable Law.

- c) The Owner shall identify and hand over the site for erection & commissioning of CAAQMS free from all encumbrances.
- d) The Owner shall make the arrangement for electricity & telephone connection at the site. However monthly charges for both electricity and phone bill shall be borne by the Contractor.
- e) The valid data display rate should be minimum 90%. The full payment shall only be made if validated data is 90% and all the calibration protocol maintenance scheduled and spare parts/ consumable replacement document are maintained and verified by the owner/ board. The contractor has to maintain records / Receipts/ bills paid available as and when required

## **12. HANDING OVER OF CAAQMS**

On expiry/closure/termination of the Contract Agreement, CAAQMS shall be handed over to Board in working condition to the satisfaction of Board. Few or all the spares procured by the Contractor and unused as on date of handing over may be purchased by the Owner at his discretion provided Contractor is able to provide reasonability of the costs of such spares. In addition, the Contractor shall provide consumables equivalent to three months' consumption on expiry/closure/termination of the Contract Agreement without any extra financial implication.

## **13. RELOCATION OF CAAQMS**

During contract period, if Board intends to shift CAAQMS from one location of the city to another location, due to some reason - functional or otherwise, Bidder shall shift the CAAQMS for which cost of shifting including dismantling, loading & transportation, reinstallation at new location and construction of foundation will be made by the Board at a mutual agreed cost.

## **14. PENALTIES**

**During O&M period, for a failure of Data display:**

Board/panel, a penalty will be charged by HSPCB @ Rs. 1,000/- (one thousand) per day after a grace period of three (3) continuous non- working days. The grace period of three (3) continuous non-working days shall be given only once per quarter (3 months).

Failure due to power outage and other Force Major conditions shall not be considered for levy of penalty.

Total penalty per year during O&M period on account of above conditions shall be limited to 30% of total O&M charges for one year. Failing which defective/ malfunctioning system has to be replaced.

In case penalty in the year exceeds 30% as above, the Contractor shall be required to replace the defective equipment with new ones at his own cost, failing which the HSPCB shall have the right to terminate the O&M contract.

## **15. SCHEDULE**

The Contractor shall carry out Operation & Maintenance of CAAQMS for a period of

five (5) years from the date of commissioning of the CAAQMS, which can be extended at the mutually agreed rates and terms and conditions.

The operation and maintenance contract shall be executed by the Member Secretary of Haryana State Pollution Control Board having jurisdiction or the area under his control. The term and condition shall be governed as per the tender document. The Member Secretary of HSPCB or any person authorized by him shall be the ultimate consignee.

VOLUME – I

SECTION III

General Condition of Contract

## **GENERAL CONDITIONS OF CONTRACT**

These conditions encompass all the Works to be executed and completed by the Contractor for the Project and as further defined herein.

### **1. DEFINITION**

Unless the context of the General and-Special Conditions of Contract otherwise requires, the following terms wherever in the General and Special Conditions of Contract shall have the meaning defined hereunder.

Words imparting the singular shall also include the plural and vice versa where the context requires. Whether the words and phrases defined in this clause are capitalized or not in the Contract shall not affect their meaning.

“The Project” or “The Works” means O&M services of CAAQMS for Continuous Ambient Air Quality Monitoring Stations (CAAQMS) at defined locations under the supervision and control of Haryana State Pollution Control Board, C-11, Sector 6, Panchkula.

“The Contract” means the written agreement to be concluded between the Board and the Contractor and includes terms and conditions stipulated on the Bidding Documents and any other descriptions annexed thereto which form an integral part of the agreement to be provided by the Board.

“The Contract Price” means the price payable to the Contractor under the Contract for the full and proper performance of its contractual obligations for the Works.

“The Equipment” means all kind of materials, Machinery, Components, apparatus, articles and instruments for the Project to be provided by the Contractor to the, Board under the Contract.

“GCC” means the General Conditions of Contract contained in this Section.

“SCC” means the Special Conditions of Contract in Section VI of this Volume.

“S/W” means the Scope of Works in Section II of this Volume.

“The Contractor” means the firm supplying the Equipment and- performing the Works in connection with the Project under the Contract and includes his personal representatives, successors and authorized assignees.

“The Manufacturers” means the firms, which produce the Equipment installed by the Board or any other manufacturer who manufactures similar CAAQMS.

“The Specifications” means the specifications of the Works to be performed by the Contractor in conformity with those specified in both the Technical Specifications of Volume II and all other related documents in the Bidding Documents, and Modifications thereof or additions thereto as may from time to time be made, and approved in writing by the Board through the Consultant in case of prior to the Contract and agreed upon by both the Board and the Contractor after the Contract.

“The Sites” means CAAQMS's as specified in Clause 1 of Scope of Works (Section - II).

## **2.0 INTENT OF CONTRACT**

The intent and spirit of the Contract is to provide all the details for the Works herein specified to be fully completed within the duration of the Contract.

It is hereby understood that the Contractor, in accepting the Contract, agrees to furnish any and everything necessary for such intent notwithstanding any omission in the Contract.

All matters omitted from the Contract which may reasonably be inferred to be obviously necessary for the efficient and stable completion of the Works shall be deemed to be included in the Contract and the Contractor shall be held responsible for any errors or losses which the Contractor may make due to such omissions as above.

## **3.0 PERFORMANCE OF WORKS**

Unless otherwise provided for, the Works shall be performed by the Contractor in compliance with the conditions and the Specifications in this Bidding Documents issued by the Board and Contract to be concluded between the Board and the Contractor.

Unless otherwise agreed or stated, the Contractor shall bear all the cost and take all the responsibilities for the performance of all the Works.

## **4.0 USE OF CONTRACT DOCUMENTS AND INFORMATION**

The Contractor shall not, without the Board's prior written consent, disclose the Contract, or any provision thereof, or any specification, plan, drawing, pattern, sample, or information furnished by or on behalf of the Board, Consultant and their authorized personnel and body in connection therewith, to any person other than a person employed by the Contractor in the performance of the Contract. Disclosure to any such employed person shall be made in confidence and shall extend only so far as may be necessary for purposes of such performance.

The Contractor shall not, without the Board's prior written consent, make use of any documents or information enumerated here above except for purposes of performing the Contract.

Any documents other than the Contract itself, enumerated in here above shall remain the property of the Board and shall be returned to the Board on completion of the Contractor's performance under the Contract if so required by the Board.

## **5.0 LOCATION**

As defined by the board as per list attached for CAAQMS in the cities of Haryana.

## **6.0 LANGUAGE AND CALENDAR**

### **Language**

All documents and correspondence related to the Contract shall be made in English.

### **Calendar**

All dates, months, years and terms referred in the Contract shall relate with the Gregorian calendar, unless otherwise mentioned specifically.

## **7.0 SITE CONDITION**

### **Site Condition**

The Contractor shall study the existing Site Conditions, referring to the Bidding Documents carefully in order to familiarize themselves with the Works. The Contractor should ascertain all particulars of the location and Site conditions at their own expenses.

### **Access to Site**

The Board will give the Contractor access the Sites in order to perform the Works during the period of validity of the Contract unless otherwise provided.

## **8.0 COUNTRY OF ORIGIN**

All the Equipment spare used under the Contract shall have their origin in the eligible countries.

For the purposes of this Clause, "Origin" means the place where the Equipment were produced or manufactured. The Equipment is produced or manufactured when, though manufacturing, processing, or substantial and major assembly of components, a commercially recognized new product results that is substantially different in basic characteristics in purpose or utility from its components.

The origin of Equipment is distinct from the nationality of the Contractor.

**9.0** Omitted

**10.0** Omitted

**11.0** Omitted

**12.0** Omitted

**13.0** Omitted

**14.0** Omitted

## **15.0 PROJECTION AND SAFETY**

The Contractor shall be totally responsible for all the reasonable precautions against fire in respect of the Works, temporary works, offices, storage yards and other places and things connected therewith.

The Contractor shall comply with all rules, regulations and orders which have been made by the Government of India, the Board or any other competent authority and the contractor shall provide sufficient fire- fighting protection in respect of the safety of the property and personnel of the Board.

## **16.0 WORKS SCHEDULE**

The time schedule for the Works to be carried out by the Contractor is specified in SCC. The Contractor shall complete the Works in accordance with the Works schedule specified here above.

## **17.0 PROJECT FORMATION**

Board

The authorized personnel of Haryana State Pollution Control Board for the Project who is responsible for any coordination with the Contractor is:

Member Secretary or Authorized Representative, Haryana State Pollution Control Board,

C-11, sec-6, Panchkula, Haryana (India)

Any correspondence to or authorization from the Board shall be made with the Member Secretary here above.

## **18.0 O&M CONTRACT**

All the CAAQMS shall be under O&M Contract.

### **Period of O&M Contract**

This O&M Contract shall remain operative for the period of 5 years after the successful installation & commissioning of CAAQMS by the Contractor. The CAAQMS shall be under Operation & Maintenance Contract from the date of contract for maintenance of all the equipment shall be the responsibility of the Contractor during the validity of Operation & Maintenance Contract. The Contractor shall, in addition, comply with the performance guarantees if specified under the Contract. If, for reasons attributable to the Contractor, these guarantees are not attained in whole or in part, the Contractor shall make such changes, modifications, and/or additions to the Equipment or any part thereof as may be necessary in order to attain the contractual guarantees specified in the Contract at its own costs and expenses and to carry out further performance test.

## **19.0 INSURANCE**

The Equipment supplied under the Contract shall be fully insured (Comprehensive) in currency acceptable as per the existing Law of India against loss or damage incidental of manufacture or acquisition, transportation, storage, shipment, delivery, installation and training involved with the Works naming the Board as the beneficiary, in the manner specified in the SCC, until issuance of taking over certificate.

- A) The insurance (Comprehensive) shall be in an amount of equal to One Hundred Ten (110) percent of the value of the Equipment up to handing over of the Equipment to the Board on "All Risks" basis, including war risks and strikes, naming the Board as the beneficiary.
- B) The Contractor shall take the comprehensive all risk insurance cover for the complete station during O&M period including statutory insurance of Contractor's personnel. The value shall be 110% of the total value of the stations depreciated annually as per standard norms.

## **20.0 INSTALLATION**

Already installed

## **21.0 INSPECTION AND TEST**

The Board shall have the right to inspect and the test the Equipment to confirm their conformity to the Specifications without any extra charge to the Board by the Contractor. The Contractor shall notify the Board and the Consultant in writing, in a timely manner (at least 07 days in advance), of the schedule of inspections and test.

However, the Board reserves the right to appoint at its cost, any inspection agency (other than suggested by contractors) which will be binding on the contractor.

## **22.0 TRAINING**

Omitted

## **23.0 COMPLETION**

### **Taking Over**

Upon successful completion of delivery, installation, inspection and training of the Equipment to and at the designated Sites and O&M of the CAAQMS for the period Of 5 years, the Contractor shall notify the Board in writing that all the Works under the Contract have been completed at least 30 days before expiry of O&M Contract period.

Immediately after completion of O&M Contract period, the Board will take over the CAAQMS or make alternate arrangement for their O&M.

## **24.0 SUBMISSION OF DOCUMENTS**

The Contractor shall submit the documents specified in SCC to the Board. The Contractor shall prepare all the documents in English.

Besides the documents thereof, the Contractor shall submit the notices, reports, and other documents when deemed necessary, in accordance with the direction of the Board.

## **25.0 PAYMENT**

### **Payment**

The method, terms and conditions of payment to be made to the Contractor under this Contract shall be specified in SCC.

The Contractor's request(s) for payment for, as appropriate, the Equipment delivered and the Works performed and fulfillment of other obligations stipulated in the Contract shall be made to the Board in writing, accompanied by documents specified in SCC.

### **Currency of Payment**

The currency in which payment is made to the Contractor under this Contract shall be in Indian rupees.

## **26.0 PRICES**

Prices charged by the Contractor to the Board for the Equipment delivered and the Works performed under the Contract shall not vary from the prices quoted by the Contractor in the Financial Bid.

## **27.0 PERFORMANCE SECURITY**

### **Performance Security**

The Contractor within seven (07) days from the date of notification of award

shall furnish a Bank Guarantee from a reputed Indian or Nationalized Commercial Bank having license to do business in India to the DG&SD/Board in line with the enclosed form as per Attachment 1 Section VI towards performance guarantee for an amount equal to ten (10) percent of the total Price under the Contract for faithful and due fulfillment by the Contractor of all obligations under the terms and conditions of the Contract for supply, installation & commissioning. The Contractor shall ensure that Contract Performance Security remains valid at least half year after completion of the obligations of supply, installation & commissioning satisfactorily.

Similarly performance guarantee for an amount equal to ten (10) percent of the total Price under the O&M Contract for faithful and due fulfillment by the Contractor of all obligations under the terms and conditions of the Contract for O&M separately. The Contractor shall ensure that Contract Performance Security remains valid at least half year after completion of the obligations of O&M satisfactorily.

#### **Return of Performance Security**

The performance security will be discharged by the DG&SD/Board and returned to the Contractor after expiry of the Contractor's performance obligations under the Contract, including obligations, unless specified otherwise in SCC.

### **28.0 ASSIGNMENT**

The Contractor shall not assign in whole or in part, its obligations to perform under this Contract, except with the Board's prior written consent.

### **29.0 SUBCONTRACTORS**

The Contractor shall notify the Board in writing of all the Manufacturers awarded under this Contract and any other subcontractors involved with performance of the Works if not already specified in the Bid. Such notification, in the original Bid or later, shall not relieve the Contractor from any liability or obligation under the Contract.

### **30.0 DELAYS IN THE CONTRACTOR'S PERFORMANCE**

Omitted

### **31.0 Liability of Liquidated Damages**

Omitted

### **32.0 SUSPENSION OF WORK**

The Contractor shall not suspend the whole or any part of the Works without notice to the Board in writing. The Contractor thereupon shall do all possible endeavors to reduce any expenses or costs resulting from the suspension. Such suspension shall not nullify the Contract.

### **33.0 TERMINATION FOR DEFAULT**

#### **33.1 Termination for Default**

The Board, without prejudice to any other remedy for breach of Contract, by written notice of default sent to the Contractor, may terminate this Contract in whole or in part:

- 1) If the Contractor fails to perform any or all of the Works within the

period specified, or extension thereof granted by the Board

or

- 2) If the Contractor fails to perform any other obligations under the Contract.

### **33.2 Liability for Excess Cost for Unperformed Work**

In the event the Board terminates the Contract in whole or in part here above the Board may procure at the risk and cost of the contractor, upon such terms and in such manner as it deems appropriate, the equipment / works similar to those undelivered / unperformed and the Contractor shall be liable to the Board for any excess costs for such similar equipment / works. However, the Contractor shall continue performance of the Contract to the extent not terminated.

### **34.0 FORCE MAJEURE**

The Contractor shall not liable for forfeiture of its performance security, liquidated damages, or termination for default if and to the extent that its delay in performance or other failure to perform its obligations under the Contract is the result of an event of Force Majeure.

For the purposes of this Clause, "Force Majeure" means an event beyond the control of the Contractor and not involving the Contractor's fault or negligence and not foreseeable. Such events may include, but are not restricted to, acts of the Board in its sovereign capacity, wars or revolutions, fires, floods, epidemics, quarantine restrictions, and freight embargoes.

If a Force Majeure situation arises, the Contractor shall promptly notify the Board in writing of such condition and the cause thereof. Unless otherwise directed by the Board in writing, the Contractor shall continue to perform its obligations under the Contract as far as is reasonably practical, and shall seek all reasonable alternative means for performance not prevented by the Force Majeure event.

### **35.0 TERMINATION FOR INSOLVENCY**

The Board at any time terminates the Contract by giving written notice to the Contractor if the Contractor becomes bankrupt or otherwise insolvent. In this event, termination will be without compensation to the Contractor, provided that such, termination will not prejudice or affect any right of action or remedy which has accrued or will accrue thereafter to the Board.

### **36.0 RESOLUTION OF DISPUTES**

#### **Applicable law and jurisdiction**

The contract shall be governed by the laws of India for the time being in force and the courts in Panchkula shall have exclusive jurisdiction to adjudicate the disputes.

#### **Settlement of Disputes**

Any dispute(s) or difference(s) arising out of or in connection with the Contract shall, to the extent possible in the first instance be resolved amicably between the Contractor and the Owner.

If, after thirty (30) days, the parties have failed to resolve their dispute or difference by such mutual consultation, then either the owner or the Contractor may give notice to the other party of its intention to commence

arbitration, as hereinafter provided, as to the matter in dispute, and no arbitration in respect of this matter may be commenced unless such notice is given.

Any dispute or difference in respect of which a notice of intention to commence arbitration has been given in accordance with this Clause shall be finally settled by arbitration. Arbitration may be commenced prior to or after delivery of the Goods under the Contract.

In the case of dispute or difference arising between the owner and Contractor relating to any matter arising out of or connected with this agreement, such disputes or difference shall be settled in accordance with the Arbitration and Conciliation Act, 1996. The unresolved dispute or differences shall be referred to arbitration of sole arbitrator, to be appointed by Chairman, HSPCB. The cost of arbitration shall be shared equally by the parties. The arbitration proceedings shall be held at Panchkula, Haryana, India, and the language of the arbitration proceedings and that of documents and communications between the parties shall be English.

The decision of the arbitrators shall be final and binding upon both parties. The cost and expenses of Arbitration proceedings will be paid as determined by the arbitral tribunal. However, the expenses incurred by each party in connection with the preparation, presentation etc. of its proceedings as also the fees and expenses paid to the arbitrator appointed by such party or on its behalf shall be borne by each party itself.

### **37.0 TAXES AND DUTIES**

- a) Concessional Customs Duty (presently) shall be applicable on the equipment being imported by Haryana State Pollution Control Board, C-11, Sector 6, Panchkula. Necessary exemption certificate shall be issued by HSPCB and applicable Custom Duty shall be paid by PCB.
- b) HSPCB is also exempted from paying Excise Duty. Necessary exemption certificate shall be issued by the HSPCB.
- c) GST, Local taxes i.e. entry tax octroi etc. will be paid by HSPCB at actual against documentary evidence.
- d) Service Tax as applicable on incidental services like Installation, commissioning and training and O&M service etc. shall be payable extra by HSPCB.

### **38.0 INJURY AND DAMAGE**

#### **Injury or Death of Persons**

The Contractor shall be liable for and shall indemnify the Board against any liability, loss claim or proceedings whatsoever arising under any statute or law in respect of personal injury or death or any disability caused by the carrying out of the Works unless due to any act or neglect of the Board, or of any person for whom the Board is responsible.

Without prejudice to the Contractor's liability to indemnify the Board, the Contractor shall maintain and cause any manufacturers and subcontractors to maintain such insurance as necessary to cover the liability of the Contractor or, as the case may be, of such Manufacturers and subcontractors, in respect of personal injuries or deaths arising out of or in the course of or caused by the carrying out of the Works.

#### **Damage to Property**

The Contractor shall be liable for and indemnify the Board against and insure and cause any Manufacturers and subcontractors to insure against any expense, liability, loss claim or proceedings in respect of any damage

whatsoever to any real or personal property for any one occurrence in so far as such damage arises out of or in the course of or by reason of the carrying out of the Works and is due to any negligence, omission or default of the Contractor or any person for whom the Contractor is responsible or any Manufacturers and subcontractors or person for whom the Manufacturers and subcontractors are responsible.

### **39.0 ROYALTY AND PATENTS**

The Contractor shall pay all royalties and licenses fees for the use of any patented item, whether it may be an invention, method, arrangement, article, process or appliance used in connection with the performance of the Contract. The Contractor shall indemnify and save harmless the Board against any and all costs, damages and expenses of any nature or kind whatsoever which may arise out of or result from a claim by any person, firm or corporation that the manufacture, purchase, use of sale of any of the inventions, methods, arrangements, articles processes or appliances used in connection with the performance of this Contract infringes any patent of such other rights. The Contractor shall, at the request of the Board, defend the Board against any suit brought to enforce any such claim at the Contractor's expense.

In case any such patented item used on or in conjunction with the Works is in suit held to constitute an infringement of its use enjoined, the Contractor shall either secure for the Board the right to continue using the said item by suspension of the injunction, by procuring for the Board a license or otherwise, or will replace such items with a non-infringing item or modify it so that it becomes non-infringing or with the Board's approval remove the said enjoined item and refund to the Board the sums paid thereof.

### **40.0 EFFECTIVENESS**

This Contract shall come into force and effect on the date of the Letter of Award and shall be in force until the Works have been completed and all the payments have been made to the Contractor, including the payments for O&M contract period.

### **41.0 LAWS AND REGULATIONS**

The formation, validity and performance of this Contract shall be governed as to all matters by and under the laws and regulations of India and courts in Haryana shall have exclusive jurisdiction in all matters arising under this Contract.

The Contractor shall respect and abide by all laws and regulations of India and shall make its best effort to ensure that the personnel of the Contractor and their dependents, while staying in India, shall respect and abide by all laws and regulations of India. The Contractor shall protect, absolve and indemnify the Board and their representatives from any claim, loss or damage arising from any non-compliance alleged or proved, without claiming them for payment.

### **42.0 NOTICES**

Any notice given by one party to the other pursuant to this Contract shall be sent to the other party in writing and confirmed in writing to the other party's address. A notice shall be effective when delivered or on the notice's effective date, whichever is later.

#### **43.0 CLIMATE CONDITION**

Precaution and protection against the specific climate conditions in India such as heavy rain, high temperature, high humidity, gales, excessive sunshine, flooding or any other climate conditions which could cause damage upon the Equipment or otherwise interfere with the execution of the works shall be taken. The Equipment to be supplied shall be tropicalized.

#### **44.0 CONSUMABLES AND SPARE PARTS**

The Contractor shall provide the consumables and spare parts as per requirement of Operation & maintenance of CAAQMS for CAAQMS Stations. The Contractor shall guarantee the availability of all consumables, spare parts, maintenance and repair work for each station.

**Annexure-B**

**VOLUME-II**

**TECHNICAL SPECIFICATIONS  
FOR CAAQMS**

**Annexure-B**

**VOLUME-II**

**TECHNICAL SPECIFICATIONS  
FOR CAAQMS**

## TECHNICAL SPECIFICATIONS OF DISPLAY BOARD

- The Board has installed display Board as per following specification:

### 1.1 DISPLAY BOARD SPECIFICATION

1.	Size of Display System (H X W) Feet	Minimum 4 X 6 feet
	Pixel	10 mm (+/- 0.6 mm) pixel pitch
2.	Visibility Range	50 Meters (Day time)
3.	Brightness	6000 NIT or higher
4.	Display of Colour Elements	1Red , 1Green, 1Blue pixel, SMD
5.	Minimum Life span of the system	LED Life 100000 Hours
6.	Viewing angle	Viewing angle of 140 degree Horizontal And max. 60 degree Vertical
7.	Operating and non-operating Temperature	-15 to 55°C
8.	No of Color	256 brightness level dimming capability
9.	Video processing	24 bit Video processing, 100 % Digital
10.	Diode Density	10,000m <sup>2</sup> (minimum)
11.	Scan rate and refresh frequency	Scan Ratio 1:1 and with minimum 960 hz refresh frequency
12.	LED internal and External Cabinet type , Serviceability	Internal LED frame should be made of Aluminium and External cabinet should be factory made without pin holes , LED Display should be serviceable from front and back
13.	Color Temperature - Adjustable	4500 - 9000 K range
14.	input Power Requirement/ Consumption	120/240v, 50/60Hz, Power consumption 180 W (maximum)/m <sup>2</sup>
15.	Type	Discrete Diode
16.	Display Mounting	Structure based upon location. Uni Pole or hanging
17.	General	The system should also have the facility to display the environmental picture through video camera/VCR/CD player etc. for public awareness.
18.	Power Cable Laying	Depending upon location, cabling is to be done by the firm
19.	Device at station to pick up data and transmit it to LED	Display data connectivity device with GSM SIM has to be installed nearby LED board which will pick up data from station computer through Internet. LED to be placed away from through Internet LED to be placed away from the station premises.
20.	Certification	CE, UL/ULC listed
21.	IP Rating	Display Module IP67, Cabinet IP 65

## 1.2 Display Board online Data Transmission Device.

S. No.	Item Desc.	Specifications
1.	PROCESSOR	Intel I-3 or higher
2.	Memory	RAM 4 GB, SSD 256 GB
3.	Ports	a. One HDMI b. LAN Port for Ethernet Network Connection c. Minimum of 2 USB Port with support
4.	OS Support	Linux, or Windows OS
5.	Communication Options	a) LAN Communication b) Wifi Communication - Wifi Hotspot enabled/ GPRS Comm.Enabled
6.	Power Supply	5 to 12 V DC through 220 V 50Hz AC Supply adapter or USB driven.
7.	Size	Mechanical Chassis Size not to exceed 9'' x 6''x 6'' with stand alone tower/box.
8.	Operating Environment	Operating Temperature 0° C to +50° C Humidity upto 90%
9.	Device Support	05 Years
10.	Antivirus	It should be secured If Windows than life time antivirus should be there.
11.	General	Supplier will configure and deploy the communication mechanism. Complete manual of the device should be provided.
12.	Accessories	800VA UPS for PC
13.	Internet	To be provided by the vendor either through GSM /GPRS or through Wifi Enabled Dongles.
14.	Display Board should show	Last data saved.
15.	Display board should show	Last updated time should be displayed
16.	Software	The vendor is responsible to provide software which can download the data from Station computer, AQI, Advertisements etc. store it and display on the Display Board seamlessly.

1.2.2 The data from CAAQMS to display board should be transmitted in a wireless manner or suitable technology to have maximum uptime.

### 2. Data transfer to CAAQMS at public sites

Software should have provisions to receive data output including current pollutants concentration, AQI, advertisement, etc. to the CAAQMS(LEDs), to be installed at public site. For the purpose Data display device has been recommended in the document.

### 3. CONNECTIVITY FOR DATA TRANSFER

a) LEASED LINE CIRCUIT

1Mbps capacity leased line connectivity with 99% uptime service level agreement (SLA) to be

provided by the firm at each station location. The leased line may be provided on copper or optical fiber or through RF depending upon the location.

b) BROADBAND

1Mbps capacity broadband connectivity from other than one already providing leased line connectivity shall be provided by the firm at each station.

c) GSM Connectivity

Internet connectivity has been provided by the firm for the entire project duration at LED location either using GSM or Hotspot connectivity.

d) Wifi or any other mode for transmission of data

**Note: Either any of above shall be provided.**

### Technical specifications of CAAQMS installed at 3 locations

These stations are procured from M/s Envea India Pvt. Ltd., Mumbai in the year 2012-2013 and are installed at Panchkula, Rohtak and Gurugram. Out of these Rohtak and Gurugram stations has recently installed PM 10 analyzer while Panchkula station does not include PM 10 analyzer.

The system is completely functional as per following specifications: -

Brief Description	Qty. in Nos.
<b>CAAQM STATION - HOUSING/CONTAINER</b>	
Housing/Container for Continuous Ambient Air Quality Monitoring (CAAQM) Station including sampling system, internal fittings, instrument racks, electrical and gas line fittings, tools (electrical & mechanical), etc.	1 Unit
<b>SPLIT AIR CONDITIONER (AC)</b>	
Split Air Conditioner (2 Ton Capacity )	1 Unit
Split Air Conditioner (1 Ton Capacity )	2 Unit
ONLINE UNINTERRUPTED POWER SUPPLY (UPS) 20 KVA	1 Unit
<b>CONTINUOUS AMBIENT AIR QUALITY MONITORING ANALYSER/SYSTEM</b>	
<b>General Specification for all Analyzers</b>	
Sampling System	1 Unit
19" Rack	3 Unit
<b>CONTINUOUS AMBIENT AIR QUALITY MONITORING ANALYSERS (GAS)</b>	
Ambient SO <sub>2</sub> , Analyzer	1 Unit
Ambient NO-NO <sub>2</sub> -NO <sub>x</sub> , Analyzer	1 Unit
Ambient CO, Analyzer	1 Unit
Ambient O <sub>3</sub> , Analyser	1 Unit
Ambient BTX, Analyser	1 Unit
<b>CONTINUOUS AMBIENT AIR QUALITY MONITORING ANALYSERS (PARTICULATES)</b>	
1A. Continuous PM10 Monitoring Analyzer(β-RAY) (not Available with Panchkula CAAQMS)	1 Unit
1B. Continuous PM2.5 Monitoring Analyzer(β-RAY)	1 Unit
<b>MULTI CALIBRATOR</b>	
Multi Point Gas Calibration System	1 Unit
Meteorological, Flow and Electronics Calibration	1 Unit
<b>METEOROLOGICAL SYSTEM</b>	
Meteorological System comprising of sensors for (A ) Wind Speed, (B) Wind Direction, (C) Ambient Temperature, (D) Relative Humidity, (E) Solar Radiation & (F) Rainfall, mounted on (G) Telescopic Crank-up Meteorological Tower (H) Vertical wind speed (I) Barometric pressure	1 Unit

DATA ACQUISITION AND COMMUNICATION SYSTEM	
---	--

Data acquisition and handling system at stations	1 Unit
Work Station Computer at stations (for AQI Preparation)	1 Unit

## 1. CAAQM STATION –HOUSING/ CONTAINER

- **Housing/Container:** It is designed for housing the ambient air quality monitoring instruments to protect them from dust and heat. Temperature and Humidity sensors have been installed in the housing for checking the humidity and temperature inside the station. Three Nos. 19” racks have been installed inside the station so that the analyzers are easily accessible from front & back for calibration and maintenance.
- **Dimensions:** Inside length: 4200 mm  
Inside width: 3500 mm Inside height: 2500 mm (As per the Drawing given)
- **Frame:** All the material used for the construction of the floor, frame, roof frame etc, the 4 corner posts and 8 integrated, reinforced container corners are of metal. The exterior panel of the container is made of pre-coated MS Sheet of approved colour shade. All other steel parts are hot dipped galvanized having minimum rate of galvanization of 275 gram per square meter (IS277). All joints of like metal such as steel-to-steel or aluminum-to-aluminum are protected against corrosion by liberal application of joining compound. All joints of dissimilar metals such as steel to aluminum are protected against corrosion due to galvanic action by liberal application of dielectric compound as well as jointing compound on both matingsurfaces. For lifting / fixing the container, International Standard eyebolts have been provided at the corners.
- **Paneling:** The outer paneling is of 1.2 mm of Pre-coated MS sheet to withstand external impacts and abrasions. Outer side of the MS Sheet i.e. exposed face of the sheet, is permanently colour coated with silicon modified polyester coating of dry film thickness (DFT) 20 micron (min.) of approved colour shade over primer. Innerface of the sheet have been provided with suitable pre-coating of minimum 7 micron off- white colour. The inner paneling is of PVC coated 2 mm thick aluminum sheet, fixed over an inlay of 4 mm marine plywood. 100 mm thick polyurethane insulation has been used between the outer and inner walls (Pre-coated MS sheet and Marine plywood) as insulating material. Z spacers if required are made out of at least 2 mm thick galvanized steel sheet of grade 275 as per IS:277
- **Floor:** The floor has been laid in frame of 600 x 600 mm centre to centre with 50x50x6 mm MS angle. The floor surface is of 19 mm marine plywood covered with robust quality Vinyl flooring, 2 mm thick of approved colour. The floor is acid and alkaline resistant, waterproof, easily cleanable / washable. Bottom plate of thickness 2 mm hot dipped galvanized MS Plate has been provided.
- **Outer Door:** One door of size 2000 x 900 mm has been provided at the front side (L= 4200 mm) of the station with isolated 3 - point locking & door handle flush fitted.
- **Electric Power Supply Box:** Three - phase (3 Ø) electrical wiring has been laid in ducts. Copper wiring of appropriate gauge has been used. The terminal board has been mounted in a central power distribution box. Over voltage protection for each phase has been provided along with the lightning arrester. 2 numbers Emergency cut off switch & Thermostat switch (max 350C) for power disconnection, 6 free sockets and 3 fluorescent lamps for lighting have been provided.
- The station is properly grounded with chemical earthing or as per BIS Standards with proper plate and only copper strip at least on 2 corners (diametrically opposite). One three phase energy meter (Digital Type) is installed. Weatherproof cubicles / enclosure for housing of MCB / TP & N Switch of main power termination (outside shelter) and weatherproof telephone junction box for terminations of telephone line have been provided. Proper earthing for telescopic mast of meteorological system has been provided. There is conduction between the telescopic mast of the meteorological system and the station. The guy ropes or wires have been provided for supporting the mast.

### List of Consumables:

All Fuses	: 02 set
Emergency Switch	: 02 pcs

Thermostat	: 01 pc
------------	---------

## 2. Partitioning for Calibration Gas Cylinders, Meteorological Mast and UPS:

The housing has been partitioned as per drawing to create space for storing of gas cylinders, Meteorological mast & UPS. The size is 2000 x 1400 x 2300 mm. A lockable door of size 900 x 2000 mm along-with 3 - Point locking system has been provided on the outer wall of the housing. A 300 mm, single-phase (230 volts  $\pm$ 10 volts AC and 50 Hz  $\pm$ 3%) exhaust fan with safety grills has been provided. Mounting brackets in 2 levels for fixing of at-least 06 (six) gas cylinders have been provided. The internal lights of the housing are sensor based.

Air conditioners have been mounted on proper rust proof supporting structures with rubber blocks to avoid vibration of structures. Proper caging / grill has been provided for the safety of ACs. Sun shades for external AC units have been provided with fabricated pre-coated MS sheet (same as monitoring station) with supporting arrangements. AC unit's external piping have been placed in GI trays. Cable trays fixed on exterior wall are covered with pre-coated MS sheet, of same colour shade of monitoring station. Roof top sheet is levelled and sloped properly. Rain water spout has been fixed at top with rain water down pipe at two corners. The external lights of the station are Solar operated.

### Station Furnishing:

- 19" racks - 03 Nos.
- Fire extinguishers - 02 Nos. (Clean Agent - 2 KG each)
- Furniture:
  - Material - Furniture made of water resistant laminated board
  - Cupboard - As per drawing
  - Working table - Powdered coated MS frame size 1400 x 900 x 750 mm (w x d x h) and top 19 mm thickness Board
  - Revolving tilting chair - 02 Nos.
- Miscellaneous
- The exhaust gases from the analyzer are collected and discharged by a common exhaust pipe and vented.
- Folding aluminum ladder for roof access (Length.... with 1 feet width steps)
- Sensor for measuring the inside temperature of the station and Display
- Hygrometer for measurement of Humidity inside the station and Display
- Mounting bracket for the ladder
- No smoking stickers
- Vacuum cleaner with minimum 100 watt power
  - Tool Kit having following tools:
    - One screw driver set
    - One Digital multi-meter (Philips, Micro or equivalent make)
    - One box spanner set
    - One D spanner set
    - One watch maker set
    - One Hammer set
    - One precision screw driver set
    - One pliers set
    - One Tong tester
    - One Soldering Iron with stand
    - One Emergency LED Cluster light
- Sign boards along-with logo of Haryana State Pollution Control Board, are embedded with size 1500 x 900 mm on the front of the container and on the two side of the container, The name of the Station i.e. Continuous Ambient
- Air Quality Monitoring Station, (Location) both in English and Hindi or local language to be inscribed. The Signs boards have been mounted on the station with proper spacers.

### **Container Foundation (RCC)**

L X W 6000 x 6000 mm

Height 300 mm from ground

**Pillars:** Nine concrete pillars of 300 mm above the ground level and below the ground level with 200 x 200 mm beam and between pillar bricks have been for filling the space (**concrete ratio of 1:2:4**). Outer wall of the foundation to be plastered with 1:4, Cement: Sand ratio and same have been painted with weather proof coat.

**Top of the platform:** RCC 150 mm with concrete ratio of 1:1:2 and to plaster and painted with weather proof paint.

**Staircase:** RCC Steps/Iron to approach the main door of the container and the UPS / Gas room door in the side has been provided and each step is not more than 150 mm

### **Security Cabin**

A 4 feet x 4 feet wooden / paneled security cabin with chair and small folding table for security guard with covered overhead selves has been provided separately with the station container.

## **2. SPLIT AIR CONDITIONER**

### **SPLIT AIR CONDITIONER (2.0 TON CAPACITY)**

Type & Capacity: 2 Nos. split type, 2 ton capacities AC, roof mounted of 5 star rating with an automatic timer. Separate Automatic Voltage stabilizer has been provided with each unit.

The indoor units are running alternately at an interval of four hours with timer control and the temperature inside the station has been maintained at 25<sup>0</sup>C inside during all the time including peak summer months.

- a. Cooling Capacity: 7000 W
- b. Star Rating: BEE 5 star
- c. Indoor Noise Level: 40db
- d. Control Type: Remote
- e. Compressor: Rotary
- f. Refrigerant: Eco Friendly
- g. Feature: filter clean Indicator, defrosting Sensor
- h. Power supply: 230 volts  $\pm$  10volts AC and 50 Hz  $\pm$  3%
- i. Standard Warranty
- j. Remote: LCD Wireless.

### **SPLIT AIR CONDITIONER (1.0 TON CAPACITY)**

Type & Capacity: 1 Nos. split type, 1 ton capacity AC, roof mounted of 5 star rating with an automatic timer. Separate Automatic Voltage stabilizer has been provided with each unit.

The indoor units are running alternately at an interval of four hours with timer control and the temperature inside the station is maintained at 25<sup>0</sup>C inside during peak summer months.

- a) Cooling Capacity: 3400 W
- b) Star Rating: BEE 5 star

- c) Indoor Noise Level 40db
- d) Control Type: Remote
- e) Compressor: Rotary
- f) Refrigerant: Eco Friendly
- g) Feature: filter clean Indicator, Pre-coated Aluminium fins etc.
- h) Power supply: 230 volts  $\pm$  10volts AC and 50 Hz  $\pm$  3%.
- i) Standard Warranty
- j) Remote: LCD Wireless.

### 3. ONLINE UNINTERRUPTED POWER SUPPLY (UPS)

#### ONLINE UPS 20 kVA, CAPACITY (Three Phase I/P & Single Phase O/P, with 01 hours backup) (for Air Conditioner)

Three phase 20 kVA UPS along with Automatic Delayed Restoration Device (ADRD) with 1-hour backup in full capacity has been provided for the smooth operation of one 2 Ton capacity split AC at the station.

- a) Capacity : 20.0 kVA
- b) Technology : PWM using IGBT / MOSFETS
- c) Crest Factor : More than 3: 1
- d) Input Voltage : 415 V AC
  - Voltage Range :  $\pm$  25%
  - Frequency : 50 Hz  $\pm$  3%
- e) Output Voltage : 230 V AC
  - Voltage :  $\pm$  1%regulation
  - Frequency : 50 Hz
  - Frequency :  $\pm$  0.01%regulation
  - Waveform : Pure sine wave
- f) Battery /Battery type : Sealed maintenance free
  - Back up time : 2 Hour at full load Battery Capacity :  
For required backup time
  - Recharge time : 5 hrs to 90% after complete discharge
- g) Distortion : Less than 1% on linear load
- h) Power factor : 0.9 to 1
- i) Indicator : L.E.D. - Battery Charge, Load level, on Line, over load, on battery, replace battery
- j) Alarm : Audible alarm for battery backup, battery low, and fault
- k) Protections Surge : Surge suppression meets BIS
  - or International standard
  - Overload : Fuse & current limited
- Short circuit : Fuse & current limited & cut - off
- cut - off : No battery drain after cut - off
- off
- l) Overload Capacity : 110% for continuous load
- m) Efficiency : More than 90%
- n) Environment Operating Temp. : 0 - 50<sup>0</sup> C
  - Operating Hum. : 10% to 95% (Non condensing)
  - Audible Noise : Less than 45 db (at 1 meter)

## 4. CONTINUOUS AMBIENT AIR QUALITY MONITORING ANALYZERS for SO<sub>2</sub>, NO-NO<sub>2</sub>-NO<sub>x</sub>, CO, O<sub>3</sub> and BTX

### 4.1 General Specifications for all Analyzers

1. The analyzers are 19" rack mounting model with facilities for fixing the analyzers from front side.
2. The front panel have ON / OFF Switch.
3. The display of the entire important status signal viz. Sample flow, temperature, concentration, range selection, manual / auto mode, zero / span mode and all error messages are on front panel.
4. The analyzers should operate at operating voltage 230 volts  $\pm$  10 volts AC and 50 Hz  $\pm$  3% frequency. The power supply input to be protected against spikes from and to the analyzer by an LC filter. The power connection cable should be CEE type complete with 15 Amperes plug adaptable to Indian mains socket.
5. The analyzers function properly in Indian conditions without any defect between 0 - 50<sup>o</sup> C ambient temperature, 10 - 95% relative humidity and in high ambient dust levels. The data capture rate is less than 90% of operational time.
6. The Manufacturer has provided comprehensive hands-on training for operational & preventive maintenance for one week in the respective State for three persons per station.
7. The analyzers are complete with calibration system. The calibration system has been delivered along-with respective span gas cylinder and permeation tubes. The span gas concentration is within 60 - 90% of first measuring range. The analyzers have zero point internal calibration system and in agreement with minimum detection limit of each analyzer. The calibration procedures are integrated into the software system for automatic calibration & remote calibration.

### 4.2 CALIBRATION GAS CYLINDER

The supplier has supplied the calibration gas cylinder (highly polished aluminium 10 liters water capacity), along with SS Regulator, traceable to NIST for each components (SO<sub>2</sub>, NO, CO, Benzene & Toluene) along with SS regulator for the multipoint calibration. The synthetic air and N<sub>2</sub> cylinder (99.99% purity with certificate) are in Carbon Steel cylinder of 47 Liters water capacity along with SS Regulator.

The analyzers have been supplied with all ancillaries necessary for operation with pump (preferably in built) and any other items such as charcoal scrubber, Teflon air sample intake filter, drier, Teflon tubing suitable for connection to air sampling manifold. All such items are itemized. Dust filter in all the analyzers have been provided before solenoid valve to protect frequent chocking of solenoid valve.

The connector systems for out-going signal for recording and the computer terminal should be on back panel with screw type connecting pins.

All ambient gas analyzers have been approved by the USEPA / TUV / MCERTS / EN. However, in case of BTX and Ammonia Analyzer specifications as given ancillaries considered. Method of measurement used also comply with the stipulation on National

Ambient Air Quality Standards (NAAQS) 2009 (Details of Methods of Measurement is available at MoEF and CPCB websites). All analyzers are micro -processor controlled with automatic calibration using an external dilution calibrator and calibration standards. All analyzers are fully integrated in the rack cabinet, fully calibrated & tested before supply and ready for start - up at the respective sites. Analyzer exhibits performance equal to or better than values specified in the Calibration & test certificate provided with each analyzer.

The manufacturer specified the cross sensitivity of measurement for all the analyzers. Each set of analyzers have been supplied with two copies of elaborate operation manuals comprising details as below:

Parts (I) comprise installation, operational and troubleshooting details;

Parts (II) have details about preventive, routine and corrective maintenance;

Parts (III) comprise details of all electrical, electronic and pneumatic circuit diagrams, details of each spare parts, catalogue No. etc. and details of each electronic card / PCB's; and

- Parts (IV) Schematic diagram for possible repair & maintenance
- Parts (V) Standard Operating Procedure (SOP) for each analyzer.
- Parts (VI) List of equipments and other accessories along with contact details of supplier.

Digital Output:

- a) RS 232 cable, TCP/IP Ethernet connection port shared between gas Analyzers, Dust Analyzer (PM<sub>2.5</sub> & PM<sub>10</sub>), Meteorological Sensors and computer for data, status and control.

**Quality Control and Standard**

Data is collected and validated according to US EPA standards, using the methodologies included in 40 Code of Federal Regulations. All analyzers have current US EPA reference or equivalent method designation and are of the latest design.

The supplier has submitted a Standard Operating Procedure for the air quality monitoring stations to the Buyer at the time of bid submission. This Standard Operating Procedure has been approved by the Buyer prior to award. The Standard Operating Procedure contains the following:

- i. Operating procedures for all analyzers and meteorological sensors
- ii. Calibration procedures
- iii. Calibration schedule
- iv. Maintenance procedures
- v. Maintenance schedule
- vi. Data validation procedures
- vii. Quality Assurance procedures
- viii. Sample quality assurance documentation
- ix. Sample Air Quality Report

The calibration procedures for analyzers conform to US EPA methodologies and include daily calibration checks, by weekly precision checks and linearity checks every six weeks. All analyzers undergo full calibration in every three months. Data obtained from these calibration checks and copies of associated Quality Assurance and calibration documentation, is submitted to the HSPCB along with the Air Quality Data.

Air Quality Data is submitted on Real Time basis through automated system and on a monthly basis in the form of an Air Quality Report. This report includes tabular and graphic information on gas and dust concentrations as well as meteorological data for each site. The data is reported in the form of 15 minute averages and shall also include daily, weekly and monthly averages, minimum, maximum, standard deviations, total data captured and percent data capture. It also has stat validation mechanism and delayed data check mechanism. The Air Quality Report also includes wind roses where wind speed and direction are measured.

Upon 24 hour notice from the Buyer, once per year, the supplier agreed to submit to an audit of calibrations, conducted, using pre-approved US EPA methodologies, by a third party. The results of these audits are made immediately available to both the supplier and Buyer.

**4.3 SAMPLING SYSTEM**

A suitable sampling system as specified by USEPA having 10 ports manifold and fitted with a suction pump to draw ambient air. System duly equipped with moisture removal systems has been provided for sampling of ambient air separately for gaseous and dust measurement.

Gases sampling system:

- Height of the sampling system: Approx. 1.0 meter above the roof
- Roof entry cut out: Stainless Steel
- Conduit: Stainless Steel
- Inner sampling system: Borosilicate glass
- Sampling head: Stainless Steel
- Manifold: 10 port for tubes 6 x 1 mm, self-tightening.
- Sample air flow sensor: Uni-directional sample air flow measuring device should be installed at the sampling system to measure the flow of ambient air

through sampling system. The output of signal has been connected to computer to ascertain the continuous flow of sample from ambient air. The suction pump operational status should also be connected to the computer as a separate channel.

#### 4.4 RACK

Suitable 19" Rack cabinet to accommodate all analyzers, calibrators, Zero air generators, data logger etc. The dimension of the rack without doors, with aluminum section and rear of 2 mm steel sheet, one removable roof plate, fitted with 4 filling eyebolts. Four roof fixing screws included in package to replace the lifting eyebolts. One gland plate three part, one pair of 475 mm (19") mounting angles depth adjustable in 25 mm pitch pattern fitted on two fixing angles approximately 150 mm unit from the front standard. To accommodate panel width of 19" size: width = 600 mm, Height = 1400 mm and Depth = 800 mm. The 19" racks have been screwed to the floor of the station with anti-vibration pads. All nuts and bolts are cadmium coated.

### 5. AMBIENT AIR QUALITY MONITORING ANALYSERS (GAS)

#### 5.1 AMBIENT SULPHUR DIOXIDE (SO<sub>2</sub>) ANALYSER

01.	Principle	:	Pulsed UV Fluorescence
02.	Measurement	:	SO <sub>2</sub> in Ambient Air
03.	Display	:	Digital
04.	Ranges	:	Auto ranging 0 - 200 ppb
05.	Lower Detectable Limit	:	1 ppb
06.	Noise Level	:	0.5 ppb
07.	Zero Drift	:	< 1 ppb/24 Hrs. with automatic zero compensation
08.	Span Drift	:	<1 ppb in 24 hrs.
09.	Linearity	:	± 1% of full scale
10.	Response Time	:	120 sec or less
11.	Span check facility	:	Span cylinder for SO <sub>2</sub>
12.	Calibration	:	Please see Multi-calibration section (Sl. No. 7) and also calibration section in General Specifications(4.1.7 to 4.1.9)
13.	Analog Output	:	0 - 1 V, 0 - 10 V, 2 - 20 mA / 4 - 20 mA
14.	Digital Output	:	USB port /TCP/IP, Ethernet

#### 5.2 AMBIENT OXIDES OF NITROGEN (NO-NO<sub>2</sub>-NO<sub>x</sub>) ANALYSER

01.	Principle	:	Chemiluminescence
02.	Measurement	:	NO-NO <sub>2</sub> - NO <sub>x</sub> in Ambient Air
03.	Display	:	Digital
04.	Ranges	:	Auto ranging 0-2000 ppb
05.	Lower Detectable Limit	:	1 ppb
06.	Noise Level	:	0.5 ppb
07.	Zero Drift	:	< 1 ppb/24 Hrs.
08.	Span Drift	:	< 2% in 15 days of full scale
09.	Linearity	:	± 1% of full scale
10.	Response Time	:	120 sec or less
11.	Span Check	:	Span cylinder for NO-NO <sub>2</sub> -NO <sub>x</sub>

12.	Calibration	:	Please see Multi-calibration section (Sl. No. 7) and also calibration section in General Specifications (4.1.7 to 4.1.9).
13.	Analog Output	:	0 - 1 V, 0 - 10 V, 2 - 20 mA / 4 - 20 mA
14.	Digital Output	:	USB port/TCP/IP, Ethernet

### 5.3 AMBIENT CARBON MONOXIDE (CO) ANALYSER

01.	Principle	:	Non Dispersive Infra-Red (NDIR) with GasFilter Correlation
02.	Measurement	:	CO in Ambient Air
03.	Display	:	Digital
04.	Ranges	:	Auto ranging 0 - 100 ppm.
05.	Lower Detectable Limit	:	0.1 ppm
06.	Noise Level	:	0.05 ppm with time constant ± 30 seconds
07.	Zero Drift	:	< 0.2 ppm/7 days
08.	Span Drift	:	< 1% full scale in 24 hrs.
09.	Span Check	:	Span cylinder for CO
10.	Linearity	:	Continuous ± 1%
11.	Response Time	:	30 seconds or less
12.	Calibration	:	Please see Multi-calibration section (Sl. No. 8) and also calibration section in General Specifications (4.1.7 to 4.1.9).
13.	Analog Output	:	0 - 1 V, 0 - 10 V, 2 - 20 mA / 4 - 20 mA
14.	Digital Output	:	USB port /TCP/IP, Ethernet

### 5.4 AMBIENT OZONE (O<sub>3</sub>) ANALYSER

01.	Principle	:	UV Photometric / Chemiluminiscence
02.	Measurement	:	O <sub>3</sub> in Ambient Air
03.	Display	:	Digital
04.	Range	:	Auto ranging 0 - 500 ppb
05.	Lower Detectable Limit	:	1.0 ppb
06.	Noise level	:	± 0.5 ppb
07.	Zero Drift	:	< ½% per month
08.	Span Drift	:	< 1% per month
09.	Linearity	:	Continuous ± 1%
10.	Response Time	:	30 seconds or less
11.	Calibration	:	With built in Zero and span generator and also see Multi-calibration section (Sl. No. 8)
12.	Analog Output	:	0 - 1 V, 0 - 10 V, 2 - 20 mA / 4 - 20 mA
13.	Digital Output	:	USB port /TCP/IP, Ethernet

## 6.0 AMBIENT BTX ANALYSER

### 6.1 GENERAL

A complete analyzer system comprising of sampling pump, transfer line, analyzer, detector, calibrator, computer hardware and software for instrument control, data storage, display, acquisition, processing and for selective determination of volatile compounds in ambient air optimized for Benzene, Toluene, Ethyl Benzene and o, m, p -Xylenes. Continuous unattended measurement system of individual BTX works without external cryogenic cooling. System has protocol compatible to communicate & transfer data to DAS. Raw data storage capacity without erase minimum for three month or more. The system has been delivered with all necessary spares, consumables, tubing etc. for making it functional.

## 6.2 TECHNICAL SPECIFICATIONS

A single stage membrane Pump collect ambient sample automatically an inbuilt adsorption trap. Subsequent, the sample is dissolved and injected on wide bore capillary gas chromatographic separation. Sample volume controlled by thermal mass flow controller (dust protected). Sample flow range is 20 -100 ml/min or more (adjustable). Sample volume is between 400 ml - one liter or more of ambient air over a 10-15 min sampling cycle. All sample transfer tubing is in stainless steel and flow & pressure sensor have been preferred with digital display.

## 6.3 DETECTOR

Photo Ionization Detector (PID) or other equivalent detector as per EPA/EU/TUV/MCERT approved specifications, which do not require hydrogen or other gas to operate it. The system has auto-clean & auto calibration facilities. PID Lamp eV is 10.6 eV. PID sensitivity sensor is available to check sensitivity.

## 6.4 MINIMUM SPECIFICATIONS

Principal	: Based on gas Chromatographic separation and Photo Ionization Detector (PID)
Measurement	: Benzene, Toluene, Ethyl-benzene, m.p-Xylene and O-Xylene.
Display	: Digital
Range	: 0 - 100 ppb (0.32 - 325 µg/m <sup>3</sup> )
Lower detectable limit	: 0.2 ppb (0.65 µg/m <sup>3</sup> ) for 15 min cycle for Benzene
Temperature Range	: 5 - 35°C or more
Repeatability	: Retention Time: <0.1% RSD Concentration: <1.0% RSD
Typical Cycle Time	: Total Cycle Time should not exceed 15 min i.e. Sample Collection Time -15 min approx. Analytical Time- 15 min approx.
Sample Volume	: 1 liter for 15 min cycle.
Desorption tube	: Carbotrap
Pre concentration	: Carbopack
Span Check	: Span cylinders for Benzene, Toluene, Ethyl-benzene, m.p-Xylene and O-Xylene.
Calibration	: The Analyzer is capable to calibrate through Multi Calibration System also. Please see Multi- calibration section (Sl. No. 8) And also calibration section in General Specifications (4.1.7 & 4.1.9).
Analog Output	: 0 - 1 V, 0 - 10 V, 2 - 20 mA / 4 - 20 mA
Digital Output	: USB port /TCP/IP, Ethernet

## 7.0 CONTINUOUS AMBIENT AIR QUALITY MONITORING ANALYSERS(PARTICULATES)

### 7.1 CONTINUOUS PM<sub>10</sub> MONITORING ANALYSER (β-RAY ATTENUATION)\*

Based on the principle of β-ray attenuation, particulate sampled through the instrument and collected on fiberglass filter tape. Before and after sampling, β- ray radiation is measured by scintillation / G.M. counter. An internal microprocessor handles all sequences and automatically calculates the concentration of PM<sub>10</sub>.

01.	Principle	: β-ray attenuation
02.	Particle Size Cut Off	: 0 - 10 Microns

03.	Measuring Range	: User selectable (0 - 500, 0 - 1000 & 0 - 2000 $\mu\text{g}/\text{m}^3$ ) with auto ranging feature	0 -
04.	Resolution	: 1% of the measurement range	
05.	Lower Detectable Limit	: 2 $\mu\text{g}/\text{m}^3$	
06.	Detector	: Plastic Scintillator / GM Counter	
07.	Air Flow Rate	: At least 1.5 m <sup>3</sup> / hr	
08.	Filter Material	: Glass Fiber Filter	
09.	Display	: LED / LCD	
10.	Sampling Head	: Dynamic heated sampling head for measurement of PM <sub>10</sub> , with adjustable temperature 20 - 70°C	
11.	Calibration	: Reference membrane facility should be provided for calibration of analyzer.	
12.	Compatibility	: Analyzer is compatible with protocols of DAS system to be used in station.	
13.	Analog Output	: 0 - 1 V, 0 - 10 V, 2 - 20 mA / 4 - 20 mA	
14.	Digital Output	: USB port /TCP/IP /Ethernet	
15.	Roll Length	: Minimum 20 meters	
14.	Measurement interval	: 1min. to 60 minute (user selectable) Generally measurement is done at a frequency of 15 minutes.	

**\*PM 10 analyzer available at Rohtak and Gurugram Station only**

## 7.2 CONTINUOUS PM<sub>2.5</sub> MONITORING ANALYSER ( $\beta$ -RAY ATTENUATION)

Based on the principle of  $\beta$ -ray attenuation, particulate sampled through the instrument and collected on fiberglass filter tape. Before and after, sampling  $\beta$ -ray radiation is measured by scintillation / G.M. counter. An internal microprocessor

handles all sequences and automatically calculates the concentration of PM<sub>2.5</sub>.

01.	Principle	: $\beta$ -ray attenuation
02.	Particle Size Cut Off	: 0 - 2.5 Microns
03.	Measuring Range	: User selectable (0 - 500, 0 - 1000 & 0 -2000 $\mu\text{g}/\text{m}^3$ ) with auto ranging feature
04.	Resolution	: 1% of the measurement range
05.	Minimum Detectable Limit	: 2 $\mu\text{g}/\text{m}^3$
06.	Detector	: Plastic Scintillator / GM Counter
07.	Air Flow Rate	: At least 1.5 m <sup>3</sup> / hr.
08.	Filter Material	: Glass Fiber Filter
09.	Display	: LED / LCD
10.	Sampling Head	: Dynamic heated sampling head for measurement of PM <sub>2.5</sub> with adjustable temperature 20 - 70 OC
11.	Calibration	: Reference membrane facility should be provided for multipoint calibration of analyzer.
12.	Compatibility	: Analyzer is compatible with protocols of DAS system to be used in station.
13.	Roll Length	: Minimum 20 meters
14.	Analog Output	: 0 - 1 V, 0 - 10 V, 2 - 20 mA / 4 - 20 mA
15.	Digital Output	: USB port /TCP/IP, Ethernet
16.	Measurement Interval	: 1min. to 60 minute (user selectable) Generally measurement is done at a frequency of 15 minutes.

## 8. MULTICALIBRATOR

Calibration system provides for the calibration of the ambient air quality monitoring analysers (Gas).

### MULTI POINT GAS CALIBRATION SYSTEM:

1. The Gas Calibration System is capable to do the following:
  - (i) Multipoint calibration using automatic dilution system for the calibration of SO<sub>2</sub>, NO, CO, and BTX analyzer.
  - (ii) Auto calibration (user selectable).
  - (iii) Generate zero air of 99.9% purity (High Performance Zero Air Generator to be provided).
  - (iv) Gas Phase Titration (GPT) with O<sub>3</sub> generator having 100% converter efficiency for conversion of NO<sub>2</sub> to NO.
  - (v) Calibration using permeation tubes for which at least two chambers based Permeation system has to be provided.
  - (vi) The Permeation System should be capable to accept permeation tubes up to 6 cm in length and 2 cm in diameter with user selectable temperature setting of 40 °C and 50 °C.
2. System should be 19" rack mountable.
3. System should be DAS compatible for remote calibration from Central Server.
4. The system should also have facility for multipoint calibration of Ozone analyzer.

## 9. METEOROLOGICAL, FLOW AND ELECTRONICS CALIBRATION

The supplier has provided calibration devices or calibration check devices for all the meteorological parameters namely temperature, wind speed, wind direction, relative humidity, solar radiation, rain fall as per the specifications of the manufacturers.

## 10. METEOROLOGICAL SYSTEM

The meteorological instrumentation has been interfaced directly with the Data Acquisition System after passing through a lightning protection isolation box. A crank- up telescopic 10 meters tower has been erected for mounting of meteorological sensors. The relative humidity and solar radiation sensors are mounted on the tower. The specifications are as follows:

### (A) WIND SPEED

Range (Operation)	:	0 - 60 m/s or better
Sustainability	:	Up to 75 m/sec
Accuracy	:	± 0.5 m/sec or better
Resolution	:	0.1 m/sec
Sensor Type	:	Ultrasonic
Threshold	:	0.5 m/sec or less
Response time	:	10 sec or better

### (B) WIND DIRECTION

Range	:	0 - 359 degree
Accuracy	:	± 3 degree or better
Resolution	:	1 degree
Sensor type	:	Ultrasonic
Threshold	:	0.5 m/sec or less
Response time	:	10 sec or better

### (C) AMBIENT TEMPERATURE

Range	: -10 ° C to 60 ° C
Accuracy	: ± 0.2 ° C or better (with radiation shield)
Response	: 10 seconds in still air
Resolution	: 0.1 ° C
Sensor type	: Resistance type
Response time	: 10 sec or better

**(D) RELATIVE HUMIDITY**

Range	: 0 to 100% RH
Accuracy	: ± 3.0 % or better
Resolution	: 1%
Sensor type	: Capacitive / Solid State
Response Time	: 10 sec or better

**(E) SOLAR RADIATION**

Range	: 0 to 1500 W/m <sup>2</sup> or better
Accuracy	: ± 5.0 % or better
Resolution	: 5W/m <sup>2</sup>
Sensor type	: Silicon Photo diode

**(F) RAINFALL**

Range	: 0.2 mm to 100 mm /hr
Accuracy	: ± 5% or better
Resolution	: 0.2 mm
Sensor type	: Tipping bucket rain gauge or any other suitable sensor
Response Time	: 10 sec or better

**(G) TELESCOPIC CRANK - UP METEOROLOGICAL TOWER**

The wind speed, wind direction, temperature, relative humidity and solar radiation sensors have been mounted on the Meteorological Tower. The tower is a free standing four section telescopic tower provided with a hand crank to raise and lower the instruments mounted on the tower. Specifications are as follows:

Extended Height	: 10 meters
Retracted Height	: 2 meters
Wind load Limit	: 0.7896 sq. m. (8.5 sq. ft) at 50
mph	: 4
Number of Sections	: 4
Construction material	: Galvanised steel or aluminium

**(H) Vertical Wind speed**

Range (Operation)	: 0 - 60 m/s or better
Sustainability	: Up to 75 m/sec
Accuracy	: ± 0.5 m/sec or better
Resolution	: 0.1 m/sec
Sensor Type	: Ultrasonic
Threshold	: 0.5 m/sec or less
Response time	: 10 sec or better

**(I) Barometric pressure**

Range (Operation)	: 0 - 60 m/s or better
Sustainability	: Up to 75 m/sec
Accuracy	: ± 0.5 m/sec or better
Resolution	: 0.1 m/sec

Sensor Type	:	Ultrasonic
Threshold	:	0.5 m/sec or less
Response time	:	10 sec or better

**Note:** Humidity and temperature sensors have been supplied with weather and thermal radiation shield made of anodized aluminium and sensor has been supplied with all necessary cables, connector and mounting arrangements as required.

## 11.0 DATA ACQUISITION AND COMMUNICATION SYSTEM

### 11.1 Typical Architecture for Data Connectivity

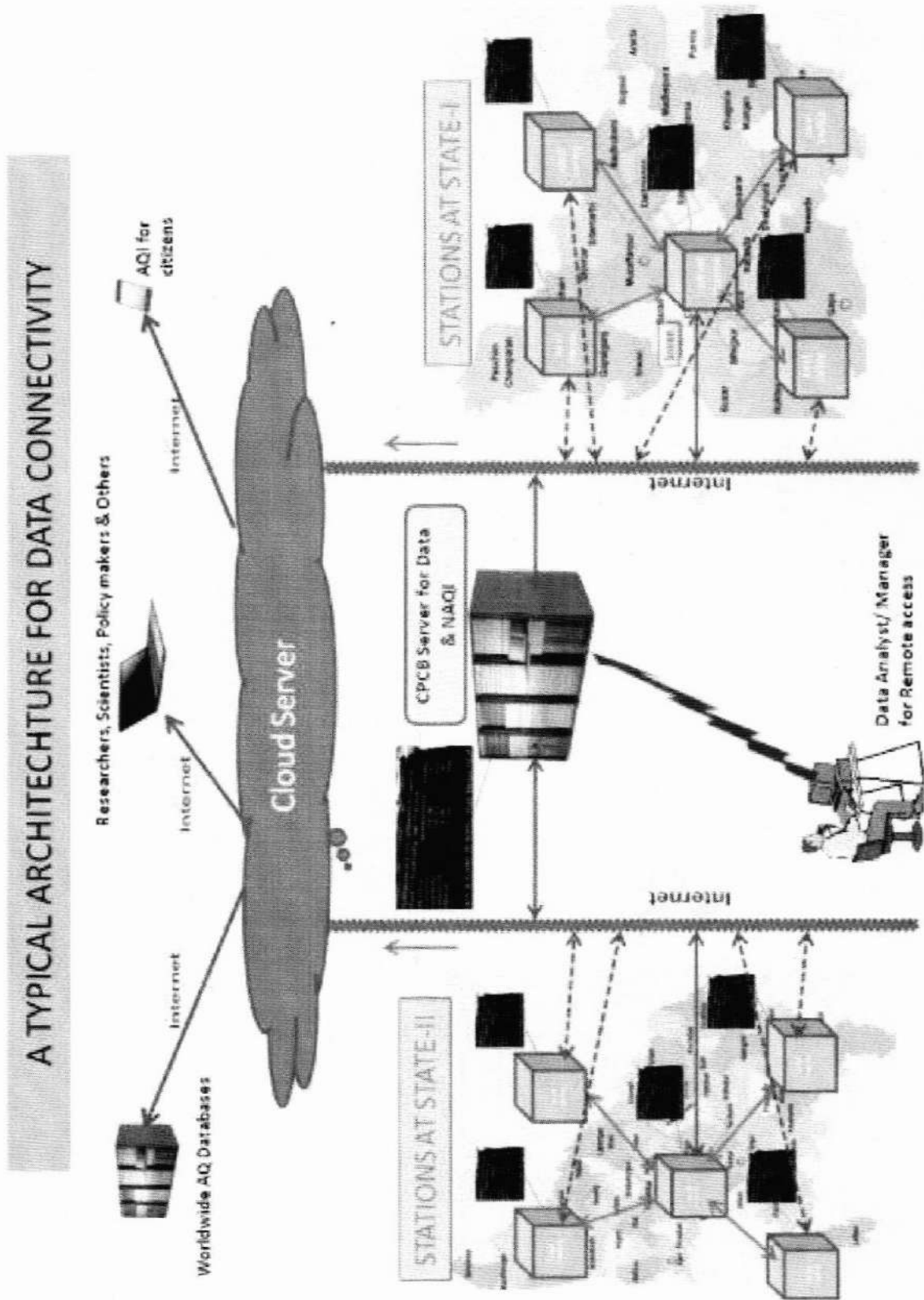

All stations are to be connected by static IP Address with CPCB server for Uninterrupted NAQI

## 11.2 Data Acquisition and Handling System at Station

Type 1: System comprises of data logger having DAS and station computer.Or

Type 2: System comprises of station computer with DAS facilities.

Data logger/DAS with 8 analog, 24 digital inputs. Ability to log channels at different intervals and have capability of averaging and displaying real time data and averaged data over a period of 1 min, 15 min, ½ hr, 1 hr, 4 hrs, 8 hrs, 24 hrs, 1 month and year. Communication between data logger and station computer is using standard USB. The data logger has internal battery with charger.

The data logger/DAS supports LAN and Internal GSM modem for data transfer to central server. Station computer for data logging are in addition to workstation computer required for calculating AQI, and are of same or better specifications that of work station computer.

## 11.3 WORKSTATION COMPUTER FOR AQI

It is installed at CAAQM station for the preparation of AQI along with the station computer.

Sr.No	Specifications	
1	CPU	Intel® Core i7 (3 GHz, 8 MB cache, 4 cores) or higher
2	Memory	8 GB DDR-III, 1066MHz,
3	Ethernet ports	Dual Gigabit Ethernet ports with autosensing bidder can provide 2nd NIC card on PCI , Autosensing is to cater to 100/1000 Mbps speeds automatically and not a boot ROM
4	PCI Slots	Provision for additional cards, 2PCI, PCIe1, PCIe16 ( Total 4 slots)
5	Optical Drive	DVD R/W 16X Drive, Internal
6	HDD's	3.5" 1TB, SATA drives
7	Power Supply	Standard suitable power supply
8	Key board	Optical Keyboard same as OEM
9	Mouse	Standard Optical Mouse same as OEM
10	I/O ports	4*USB,
11	Monitor	17" Wide LCD TFT Color Monitor
12	Wireless adapter	USB Wireless adapter x 1 no.
13	OS support	Open source Ubuntu latest release
14	Warranty	Warranty is comprehensive on site including spares for 3 / 3 / 3 years
15	Type	Tower type Black in color preferably or as per the fitting in station rack

## 11.5 REMOTE MONITORING TOOL/SOFTWARE

Remote management software and its licenses for the entire project duration for station computer and central location at HSPCB.

## 12.0 DATA ACQUISITION SOFTWARE FOR STATION (CAAQM)

The software captures data from all channels in the system and stores in the station Computer.

### (i) Data Acquisition

- a) Frequency of data acquisition
  - i) User selectable 1,5,30,60,120 second averaging duration online digitally.
- b) Channel size
  - i) 32 Channels or more supported

- ii) Expandable to 64 channels, if required in future
- c) Data input
  - Either Analog (0-1 volt/0-10 volt/2-20mA/4-20mA) or Digital to configure with the PC.
- d) User configurable channels, stations and equipment with communication parameters.
- e) Analyzer data channel comprises of Name, Units, Communication Address, Validity Range, Operation and Error Status.
- f) Provision to incorporate conversion factors such as PPB to  $\mu\text{g}/\text{m}^3$  etc.
- g) Software is equipped to configure the analyzers with it, irrespective of company make and communication protocol of the analyzer and the output mode i.e. Analog or Digital (RS 232) of the instrument.
- h) The output is provided in user defined units.

**(ii) Data Collection**

- a) Average data over user selectable time (1,5,30,60 seconds time interval) period.
- b) Operational status, Error status, calibration status and calibration values observed from the analyzer is captured and should be made available along with the data with a frequency of maximum five minutes.
- c) System collects of the diagnostics of the instrument comprising actual diagnostics parameters and their values at least once in every five minute to check the state of the health analyzer.
- d) Calibration parameters
  - i) Provision to entering zero calibration, span calibration values of gas cylinder/permeation to devices
  - ii) Provision for collecting zero calibration, span calibration values (pre calibration & post calibration) in to the database for further analysis.
  - iii) Provisions to collect electronic system pre calibration & post calibration to ascertain the percentage deviation/ correction apply during each calibration.

**(iii) Data Storage**

- a) Data along-with diagnostic, calibration, alarms are stored at station computer at a defined path.
- b) Interval of data dumping is same as defined in the data collection.
- c) System is capable to keep every second acquired data from 32 channels for a period of minimum five years.
- d) Current data is stored as per ISO-7168-1:1999I format and should be available in folder named as c:\Data\ at an interval of 15 minutes. As an example c:\data\01.05.2015.xml. the file will be appending without double data entry and as per ISO format.
- e) Data is stored for last two years in E:\data\Year\Month\day i.e. e:\data\2015\05\01.05.2015.xml ....
- f) If data encryption is done, then decryption procedure is made available in soft file format to check the data at station at any point of time.

To convert data on continuous basis for exporting to AQI software, procedure is available without any licensing. AQI calculating Software is provided by CPCB/HSPCB.

**(iv) Data Display (Statistical analysis of data)**

- a) Main window for real time display of all measured parameters with status of all analyzers/sensors.
- b) In 4-in-4 graphs and 4-in-1 graph formats
- c) In tables of 4-in-1 format
- d) Real time multi - graphs over user selectable time period i.e. 6.00 AM to 6.00AM etc.
- e) Display of graphic & tabular display of the current data.
- f) Graphical form should comprise of 4-4 graphs, 4-1 graphs in user defined format ( 1, 5, 10, 15, 30 min, 1hour, 4, 8, 24 hour, 30 days and yearly; user definable time series)
- g) Tabular form should comprise of 4 channel list in user defined format (1, 5, 10, 15, 30 min, 1hour, 4, 8, 24 hour, 30 days and yearly; user definable time series)
- h) Station instruments basic configuration etc. is visible on screen continuously.
- i) Statistical analysis tools like regression analysis, co-relation analysis and other analysis as per industry standards in the field of environment should be available and if not the firm should develop these for HSPCB within a timeframe of six months.
- j) The system has procedures for normal analysis tools like calculation of data with respect to a threshold value, average, minimum, maximum, calculation of violating value with respect defined values (National Air Quality Standards) for defined period for the database etc.
- k) Data analysis of diagnostics parameters
- l) Data analysis of Pre calibration and post calibration data (if facility not available, should be developed within six months)
- m) Data analysis of corrections applied of each calibration cycle (if facility not available should be developed within six months)

**(v) Data Backup**

- a) There is defined data backup procedure through which data is extracted from station computer in simple text format/excel/ ISO format (user definable).
- b) There is defined restore procedure also to restore the data in case of data loss.
- c) A display screen is available to update the user about data availability.

**(vi) Data Validation automatic checks at station software.**

- a) Zero level and span level checks if performed cyclically and defined results are not obtained up to +/- 5% (user definable 0-10%) then system alarms the user of system failure and the recorded alarm is transmitted to central software.
- b) After instruments perform the calibration the results obtained is recorded and is transmitted to central computer.
- c) There is provision of two databases one is raw database and another corrected database.
- d) Validation of data through calibration database Pre calibration & post calibration values collected.

**(vii) Calibration of systems**

- a. Calibration window for analyzer for the calibration from computer.
- b. Remote Access to Calibration: Calibration exercise are done remotely. All necessary arrangements for it are made in the system.

- c. Calibration data file is prepared separately and data is excluded from the database
- d. Calibration database is formed, stored and transmitted to central server.
- e. Calibration cycles to be as per the models of the instruments.
- f. Calibration records stores the calibration values displayed by instrument.
- g. Diagnostics during calibration is also recorded.

**(viii) Location of station**

- h. Fixed station location is recorded and North correction feature are available.
- i. Latitude and longitude of stations is recorded

**(ix) Data transfer to Central**

All data captured at station computer is transferred to central software.

- a) User selectable time frame for transmission of data to central server.
- b) Diagnostics (actual diagnostics parameter values recorded each time in the station), configurations (station channel configurations), alarms (generated alarms) should be transmitted.

**(x) Data transfer to CAAQMSat Public site**

Software has provisions to connect data output including current pollutants concentration, AQI, advertisement, etc. to the CAAQMS(LEDs), have been installed at public site. For the purpose Data display device has been recommended in the document.

**13.0 DATA ACQUISITION SOFTWARE AT THE CENTRAL STATION AT HSPCB**

Data communication system handles the data transmission of an ambient air quality network and receives incoming messages / signals from remote stations. The central software processes signals and data and displays it. Detailed requirement is as below:

**A (i) Software at Central Station**

- a) Software does not have any restriction on number of locations and computers either technologically or in terms of licensing.
- b) Display multiple stations on - line data (momentary values) in tabular text and graphic format.
- c) Data is received by the central from all locations maximally within 5minutes duration or at user defined time intervals.
- d) Data along-with diagnostics and calibration details is transmitted at central from all connected locations.
- e) Supports dialup systems, broadband connectivity, wireless connectivity, 2G or 3G or any new technology which are in place during project time are compatible and if not, are developed by the system provider up- to project duration without additional charges.
- f) Has the remote control facilities for calibrations (Zero & Span) of instruments and measuring range modifications.
- g) has facility for displaying data communication error reports, image management which are recorded and should be available for display.

**(ii) Data Display at Central Station**

- a) In 4-in-4 graphs, 4-in-1 graph and/or 16-in-1 graph formats
- b) In terms of 4-in-1 table format
- c) Real time multi - graphs over user selectable time period i.e. 6.00 AM to 6.00AM etc.

Display of graphic & tabular display of the current data like simple 3D line and column chart, polar diagnostics and 3D perspective column chart.

- c) Graphical form should comprise of 4-4 graphs, 4-1 graphs in user defined format i.e. 1, 5, 10, 15, 30 min, 1hour, 4, 8, 24 hour, 30 days and yearly. (user definable time series)
- d) Tabular form should comprise of 4 channel list in user defined format i.e. 1, 5, 10, 15, 30 min, 1hour, 4, 8, 24 hour, 30 days and yearly. (user definable time series)
- e) Display of data using selectable name of different stations.
- f) Generation of Wind Roses, Pollution Roses (minimum 12 directional) with user defined time limits.
- g) Calculate vector mean of wind direction.
- h) Programmable downloading of data.
- i) Comparison of data w.r.t. Standards in Graphical form and tabular form with information of values exceeds the Standards.
- j) Specific data zooming facility
- k) Database correction procedure
- l) Separate user ID and Password for correction of database so that all regional level users if authorized can validate their regions data and the events be recorded along-with ID and time.
- m) Data validation trail recording.

**(iii) Data Export**

- a) Data export in ISO 7168 format is done automatically.
- b) Possibility to export the data files in Excel, Text and other formats Tabular form is in user defined format i.e. 1, 5, 10, 15, 30 min, 1 hour, 4, 8, 24 hour, 30 days and yearly.

**(iv) Data Import**

- a) In case of communication medium fails there is a mechanism to shift the data into Pen drive (Physical medium for data collection) physically and a procedure to import the same on central software.

**(v) Printing**

- a) Possibility to connect different types of printers and auto printing facility for all displays generated throughout the analysis of data at any point of time.

**(vi) Delayed data checks at Central software at HSPCB**

- a) After instruments perform the calibration the results obtained are recorded and are transmitted to central computer and stored.
- b) Zero level and span level checks if performed cyclically and defined results are not obtained up to +/- 5% (user definable 0-10%) then system generates alarm to the user for system failure and the recorded alarm is transmitted to central software and stored. There are provisions to read these alarms in a database for corrective actions and for comparison of data for acceptability or rejection.
- c) Procedure to correct database through correct ISO 7168 file is generated at HSPCB and it is synced with Software under development at Haryana State Pollution Control Board (HSPCB).

**(vii) Data display at HSPCB Office / specific location through central software**

The software has capability to display set of data including AQI etc. for all the monitoring locations and cities (user selectable) in the State through slide show mechanism.

**(viii) Remote Procedures (if not available facility should be developed by the firm)**

- a) Central software has capability to allow to connect any station computer through remote.
- b) Central software administrator is able to go for remote calibration of any of the systems.
- c) Software is capable to operate remote stations configurations.
- d) Control panel window is available for controlling each analyzer.
- e) Alarm window for valid alarms of all analyzers and sensors.
- f) It has transparent data - connection to each analyzer from remote.
- g) System is capable to remotely configure all stations through remote location using configuration file to maintain the uniformity. The configuration command from central at HSPCB location is active.

**(ix) Data Reports Generation**

- a) To prepare reports hourly, weekly, monthly, yearly in user defined interval and formats.
- b) Mean, Median, Percentile, Maximum, Standard deviation, Frequency analysis and Maximum Frequency analysis.
- c) Data Comparison  
Software is able to compare any of the four channels irrespective of type of data in the system with respect to each other on a single time scale user selectable.
- d) Data Comparison on different time scale  
Software is able to compare data on the basis of different time scales like one station (x) parameter (y) of one given date is compared with other station (z) parameter (y) on any other date in a single graph.
- e) Data reports, calibration reports and status reports with user time periods.
- f) Historic multi - curves / graphs over user selectable time period.
- g) Report generation over user selectable time period (instantaneous or averaged over a period of 1, 15, 30 min, 1 hr, 4, 8, 12, 16 and 24 hrs etc.).
- h) Diurnal variation, standard deviation, regression and other statistical parameter reporting possibilities with various available mathematical methods.
- i) If required separate report generation procedures have to be developed for which firm is responsible for project duration.
- j) Data is downloadable in Excel Sheet, CSV format through user selection.

**(xi) SECURITY**

- Software is totally secured with protection against virus, malware etc.
- Security device like firewall for VPN Tunneling should be installed.

**(xii) OTHER TECHNICAL CONDITIONS**

1. Compatible Hardware required for data transmission through Data Display Connection Device has to be installed.
2. Supports the latest formats of Windows 32 bit or 64 bit. Any new patches developed or upgraded software during project duration should be provided without additional cost.
3. Manual of complete system have been provided.
4. Firm has provided the hardware required for data acquisition along with all the software's required like OS, Networking software, Remote functionality software and should maintain hardware and software for project duration.

14.0 ANNEXURE

(A) Drawing of a CAAQM Station

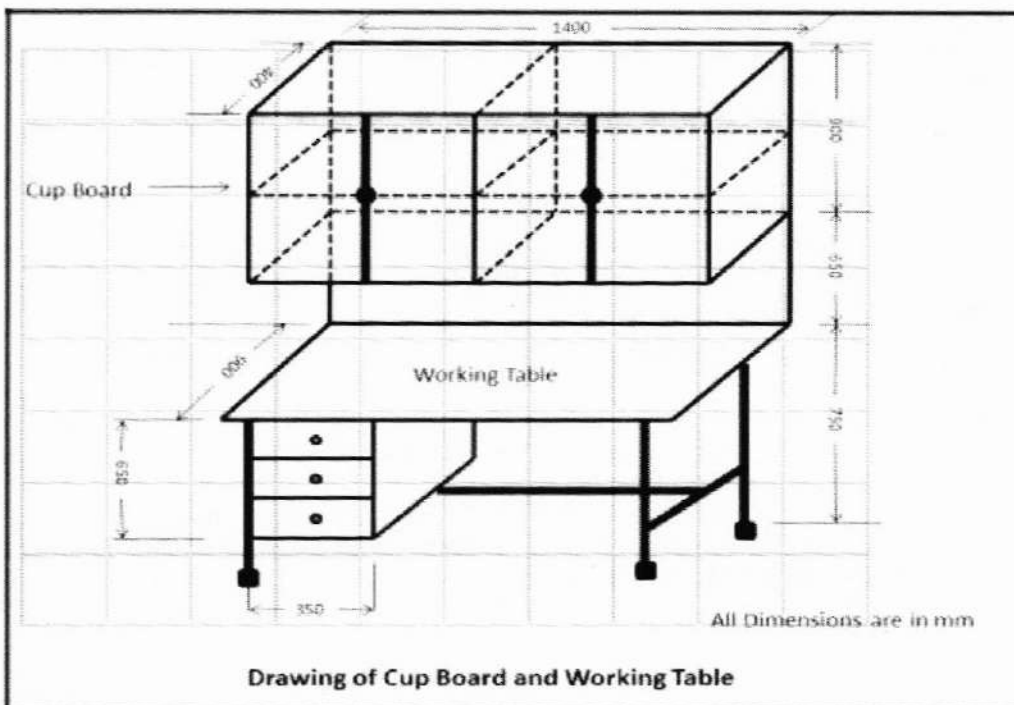
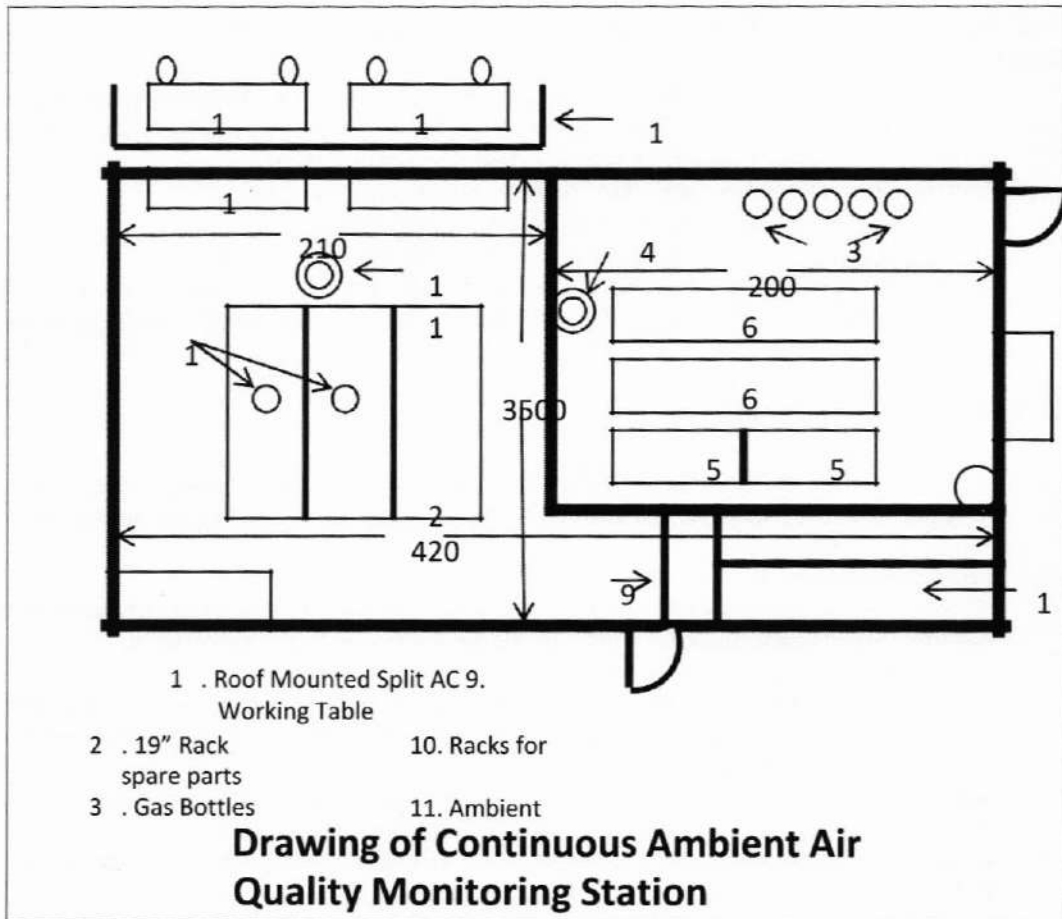

## (B) Architecture of CAAQM System

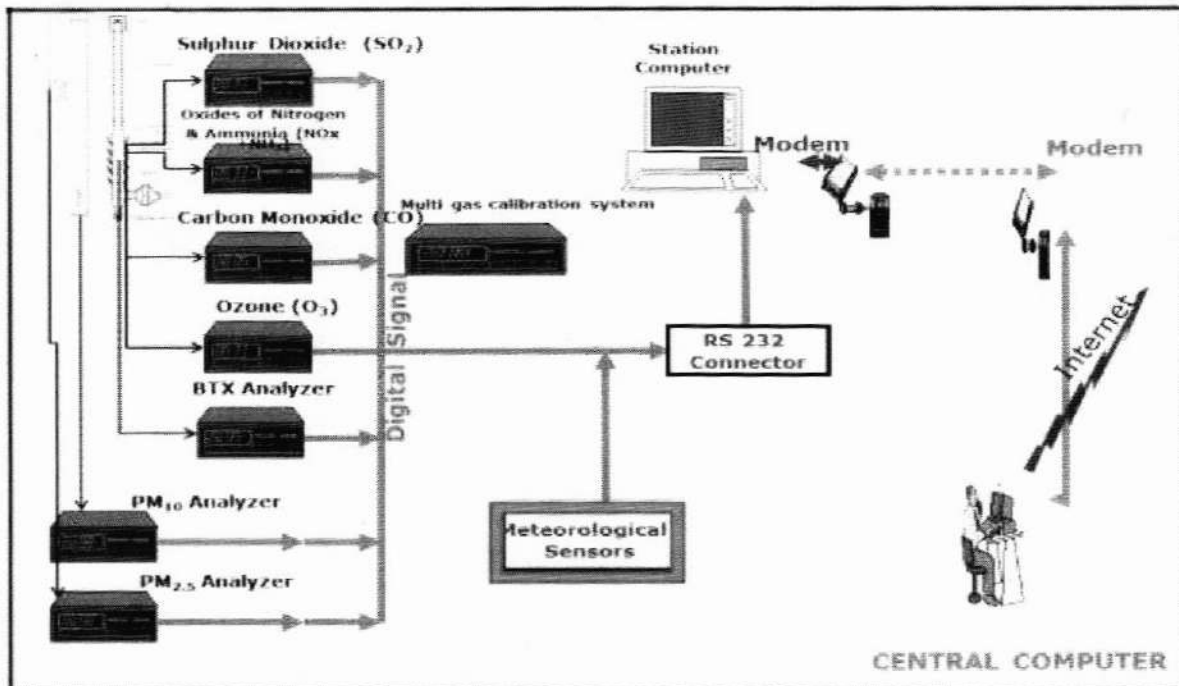

(C) Protocol for Data Transmission from CAAQM Stations

### 1. Data Format

- Data file on real time basis having 15 minutes average values in a prescribed format attached at Annexure-I is generated at the station for which Instrument Supplier is responsible.
- File should be updated after every 15 minutes.
- Data intervals like 00:15, 00:30, 00:45, 01:00 should be fixed at the station.
- Station file name is exactly as the name of the station to be displayed on the web portal. i.e. Sanathnagar, NehruNagar. Here precaution is taken that no space between words is given or no special characters have been used.
- File is recorded in a folder c: \data \sanathnagardata.txt
- File allow data appending sequentially.
- Date of last file record appended in the file is recorded and data afterwards be placed in the data file.
- File appending continue subject to max 97 lines. First in First out mechanism shall be followed in keeping file size to 97 lines.
- Hence, in the specified folder c:\Data\ there will be a single file which is kept appending as per format attached.
- Duplicate entry of any data is made in the file.
- System has capability to create previous record data file for which user will give the date. This is required to have lost data makeup in the final database, if any.

### 2. Data Mapping

Protocol for each parameter is fixed as below:

1. 15 Minutes average value is provided by the operator of theCAAQMS
2. HSPCB has the parameter as mentioned in the table only. Not even a small gap or space is provided other than the mentioned table is acceptable

### 3. Standard Parameter Naming Protocol and Conversion factors Table

Parameters Name	Parameter Abbreviations	Unit	Conversion factorsat 25° C
Rack Temperature	Temp	°C	
Carbon Monoxide	CO	mg/m3	1ppm=1.145mg/m3
Sulphur Dioxide	SO2	µg /m3	1ppb=2.62 µg/m3
Nitric Oxide	NO	µg /m3	1ppb=1.23 µg/m3
Nitrogen dioxide	NO2	µg /m3	1ppb=1.88 µg/m3
Oxides of Nitrogen	NOx	Ppb	--
Ozone	Ozone	µg /m3	1ppb=1.96 µg/m3
Particulate Matter less than 10 Micron size	PM 10	µg /m3	--
Wind Speed	WS	m/s	--
Wind Direction	WD	Deg	--
Ambient Temperature	AT	°C	--
Relative Humidity	RH	%	--
Barometric Pressure	BP	mmHg	--
Solar Radiation	SR	W/mt2	--
Rain Fall	RF	Mm	--
Vertical Wind Speed	VWS	Degree	--
Particulate Matter less than 2.5 micron size	PM2.5	µg /m3	--
Benzene	Benzene	µg /m3	1ppb=3.19 µg/m3
Toluene	Toluene	µg /m3	1ppb=3.77 µg/m3
Xylene	Xylene	µg /m3	1ppb=4.34 µg/m3
Ethyl Benzene	Eth-Benzene		1ppb=4.34 µg/m3
M+P_Xylene	MP-Xylene		1ppb=4.34 µg/m3
Methane	CH4	µg /m3	1ppb=0.65 µg/m3
Formaldehyde	HCHO	µg /m3	1ppb=1.23 µg/m3
Mercury	Hg	µg/m3	1ppb=8.20 µg/m3

Note: 1. Any other parameter can be added with the prior approval of IT Division ONLY.

#### 4. Internet Connectivity

Internet connectivity is available on 24X7 basis for data transmission with an uptime of 99.9%. For this purpose every CAAQM station has two kinds of connection:

- i) Leased Line Circuit of at least 01 Mbps capacity
- ii) Broad Band connectivity through telephone line. Both facilities are configured in ready to use condition. If possible auto failover is created.

Note: Connectivity through Data card is not acceptable except in any special circumstances, where both of these types of connectivity's are not available. For such case HSPCB IT Division shall be consulted before taking a final decision.

#### 5. Other Information:

1. Area Map showing station location
2. Latitude, Longitude and altitude of the station
3. Photo of station along with nearby areas
4. One page write-up about the station activities in the vicinity of station including major pollution sources like nearby road, rail, restaurants, Generator sets, etc.