

NATIONAL INSTITUTE FOR EMPOWERMENT OF PERSONS WITH MULTIPLE
DISABILITEIS (DIVYANGJAN), (NIEPMD)
(Department of Empowerment of Persons with Disabilities,
Ministry of Social Justice & Empowerment, Govt. of India)
E.C.R. Muttukadu Kovalam P.O, Chennai- 603 112

Tender No. NIEPMD/Pur 4 (13)/2025-26
Notice Inviting Tenders: NIEPMD & Its CRCs
Sub.: Annual Rate Contract for Purchase of Prosthetics & Orthotics (P&O)
Components /Kits, Raw Materials & Machinery Equipment (Re-Tender)

(Valid for NIEPMD Extension Centers & Composite Regional Centers (CRCs) also)

National Institute for Empowerment of Persons with Multiple Disabilities (NIEPMD), Chennai, Under Ministry of Social Justice and Empowerment, DEPwD intends to enter in to annual rate contract for a period of one year after finalization of contract. The contract may be extendable up to 02 more years subject to satisfactory performance and discretion of Director, NIEPMD. However, it is not binding for either side to extend the rate contract beyond one year. The following terms and conditions will be followed for procurement of **“Prosthetics & Orthotics (P&O) Components /Kits, Raw Materials & Machinery Equipments”** for use in P&O material Development Unit of NIEPMD & CRCs.

Last date for E-bidding	-	04.00 PM. On 04th May 2026
Tender Fee	-	NIL
EMD Amount	-	Rs. 50,000/--
Date & Time of Opening of Tender	-	04.30 PM. 05th May 2026

Tele: 044-27472046/27472113

Email: director@niepmd.tn.nic.in

Sd/-

Director

NATIONAL INSTITUTE FOR EMPOWERMENT OF PERSONS
WITH MULTIPLE DISABILITIES (DIVYANGJAN), (NIEPMD)

(Department of Empowerment of Persons with Disabilities,
Ministry of Social Justice & Empowerment, Govt. of India)
E.C.R. Muttukadu Kovalam P.O, Chennai- 603 112

Tender No. NIEPMD/Pur 4 (13)/2025-26

Notice Inviting Tenders: NIEPMD & Its CRCs

**Sub.: Annual Rate Contract for Purchase of Prosthetics & Orthotics (P&O)
Components /Kits, Raw Materials & Machinery Equipment (Re-Tender)**

National Institute for Empowerment of Persons with Multiple Disabilities (NIEPMD), Chennai, Under Ministry of Social Justice and Empowerment, DEPwD intends to enter in to annual rate contract for a period of one year after finalization of contract. The contract may be extendable up to 02 more years subject to satisfactory performance and discretion of Director, NIEPMD. However, it is not binding for either side to extend the rate contract beyond one year. The following terms and conditions will be followed for procurement of **“Prosthetics & Orthotics (P&O) Components /Kits, Raw Materials & Machinery Equipments”** for use in P&O material Development Unit of NIEPMD & CRCs:

1. Tentative purchase amount will be as per NIEPMD HRD requirement. Purchase amount may be NIL also during the year or currency of contract subject to requirement and availability of funds. No claim for minimum purchase will be entertained.
2. **Submission of Bid:** The bid should be uploaded through NIC e-procurement portal URL [“http://eprocure.gov.in/eprocure/app”](http://eprocure.gov.in/eprocure/app) up to **04.00PM till 04th May 2026, containing following:**
 - i) EMD in the manner as prescribed at Clause No.11 below.
 - ii) Bidder shall upload the scanned copies of following:
 - a) Authorized Dealer/Distributor/Business Partner/RSR Certificate from OEM.
 - b) Relevant Documents in case of MSME/SSI/NSIC Unit.
 - c) PAN Card, Address Proof.
 - d) GSTIN number certificate
 - e) BIS / ISI certification for quoted products if available. Wherever ISI / BSI certified product available, priority will be given to those product vendors only.
 - iii) Duly filled Price Bid (BOQ Provided in Excel format).
3. **Opening of Bid:** Technical Bid shall be opened on the **05th May 2026 at 04.30PM.**
4. **Bid Validity:** Bid shall remain valid for a period of 60 days from the date of opening of technical bid.
5. **Bid Evaluation:** Duly filled Price Bid shall be evaluated on lowest items basis.
6. The total cost quoted should be exclusive of taxes. Applicable taxes to be mentioned separately. Tax applicable at the time of invoice will be paid. Rate

quoted inclusive of taxes will not be accepted and such bids will not be considered for evaluation. Tax Rate quoted as ZERO will not be accepted (If material is not declared as Tax free by Govt. / GST Council). NIEPMD GSTIN number should be used for Tax invoice purpose.

7. Prices quoted by the bidder shall remain FIRM for delivery in NIEPMD, Chennai and other parts of India during the currency of contract and any extension thereof. Undertaking in this regard should be uploaded with technical bid. Conditional undertaking will not be accepted.
8. The tender submitted by any other means except NIC e-procurement portal, will not be entertained under any circumstances.
9. The list of technically qualified bidders will be published CPP portal automatically after evaluation of technical bids.
10. The financial bids of technically qualified bidders only will be opened after technical evaluation of bids as per date and time fixed on CPP portal.
11. **Earnest Money Deposit:** The Bidders shall deposit Earnest Money amounting to **Rs. 50,000.00 (Rs. Fifty Thousand only)** and non-refundable tender fees of **Rs. NIL** through e-payment as per the procedure mentioned below:

11.1 Procedure for e-payment:

EMD of Rs. 50,000/- should be paid online through NEFT or RTGS in NIEPMD account and payment receipt to be uploaded with technical bid. Technical bids without EMD shall not be considered for further evaluation. NIEPMD Bank details are as follows:

A/C No. 761297290

Type of Account: Saving Bank

Name of Bank: Indian Bank, Kovalam Branch

IFS Code: IDIB000K122

Branch Code: 01176

• **Caution:** Please ensure that you need to mention the correct beneficiary account number and IFSC code as mentioned above while making payment via RTGS / NEFT. In the event of funds remitted to wrong beneficiary account number, NIEPMD, Chennai or its Bank would not responsible for the same.

12. Tender Submission process

Interested bidder may submit their quotes by giving all the necessary documents in English or Hindi as specified. **The TENDER must be submitted online through Central Public Procurement Portal e-procurement application only through URL: <http://eprocure.gov.in/eprocure/app> only.** No manual bids will be entertained under any circumstances.

The Tender document attached must be direct, concise, and complete and arranged in an organized and structured manner.

To participate in online bidding process, Bidders must procure a Digital Signature Certificate as per Information Technology Act-2000 using which they can digitally sign and encrypt their electronic bids. Bidders can procure the same from any CCA approved certifying agency, i.e. TCS, Safecrypt, Ncode, eMudhra etc. Bidders who already have a valid Digital Signature Certificate (DSC) need not procure a new DSC.

NIEPMD will not be responsible for delay in online submission due to any reason. For this, bidders are requested to upload the complete bid proposal well advance in time so as to avoid issues like slow speed, choking of web site due to heavy load or any other unforeseen problems.

Bidders are also advised to refer visit any local NIC office or call CPPP 24x7 toll free number 1800-3070-223 or mobile No. 07878007972, 07878007973 for further details about the e-tendering / bidding process.

GENERAL TERMS AND CONDITIONS:

13. The bid is liable to be rejected if the EMD is not found in order or receipt not accompanying with the Technical Bid.
14. The EMD of unsuccessful bidders shall be returned after the issuance of award to the successful bidder. No interest shall be paid by the NIEPMD, Chennai on the EMD.
15. The EMD of successful bidders shall be retained as security deposit and released after successful completion of contract. No interest will be paid on EMD amount.
16. NIEPMD reserves the right to accept / reject / select more than one Agency and to annul the bidding process of any or all bids at any time prior to award of contract without thereby incurring any liability to the affected bidders.
17. The NIEPMD reserves the right to increase/decrease the quantity at the time of placing the order.

18. The order will be awarded for supply of P & O components & Raw Materials / Kits with the lowest item rate basis from the technically qualified bidder. **As no subsequent cost negotiations will be done, the price quoted should be final.**
19. In case **05th May 2026** happens to be holiday or non-availability of minimum bid openers, the tenders shall be opened on next working day / or on availability of bid openers.
20. NIEPMD will not provide 'C' and 'D' Form.
21. Submission of bid means that bidder has read all the terms and conditions of this NIQ carefully and will comply them all unconditionally. **Conditional bids will not be accepted.**
22. NIEPMD, Chennai reserves the right to split the quantity/items ordered on more than one vendor.
23. Approximate requirement for one year: - As per Institute HRD requirements. The requirement may be zero also.
24. The tender will be appraised by NIEPMD Purchase Committee and Officer Incharge Material Development- (Aids & Appliance).
25. **MSE/SSI Units:** The units registered with MSE/SSI/NSIC, are exempted from payment of EMD subject to following: (However no agency is exempted from paying of security deposit).
 - I. Uploading of registration certificate with District Industries Centers or Khadi and Village Industries Commission or Khadi and Village Industries Board or National Small Industries Corporation
 - II. Valid registration during validity period of quotation.
 - III. Applied for registration or for renewal will not be accepted. Such offers will be treated as offer received without EMD
26. The award to MSE Firms shall be regulated as per Govt. Guidelines.
27. **Delivery Schedule:** Purchase order shall be issued as per requirement and the firm shall ensure delivery of material within 15 days from the date of placement of each purchase order.
28. **Payment:** payment will be made after receipt of material against each Purchase Order in good condition and full quantity to the entire satisfaction of Consignee. Normally payment will be made within thirty working days after satisfactory receipt of materials. No advance payment under any circumstances will be made.
29. **Delayed delivery & Compensation for delay:**

If the delivery of material/goods in full and in good condition is not completed for whatsoever reason within the stipulated period, an amount @5% (Five percent of the undelivered material) would be deducted from the payment due to supplier for each week or part thereof, subject to the maximum of 25% (Twenty-five percent of the undelivered material). In case, short supply in all respect is delayed beyond 70 days of scheduled delivery period in that case besides LD, EMD shall also be forfeited without any notice.

Further if the delivery of material/goods is not commenced at all for whatsoever reason within the scheduled delivery period, in that case the NIEPMD reserve the right to cancel the order with forfeiture of security deposit without any notice.

In case of any defects and material is not found to be as per specification, the same shall be made good/replaced by the concerned firm as per the instructions of Consignee failing which it will attract action as above.

29. The NIEPMD reserves the right to accept or reject any or all the tenders without assigning any reason thereof whatsoever.

.....We agree to all terms and conditions as mentioned above including the validity of the offer. Utmost confidentiality of the data provided shall be maintained.

Name, Designation & Signature of the bidder with the seal

NATIONAL INSTITUTE FOR EMPOWERMENT OF PERSONS WITH MULTIPLE DISABILITIES (NIEPMD)

(Department of Empowerment of Persons with Disabilities,
Ministry of Social Justice & Empowerment, Govt. of India)

East coast Road, Muttukadu, Kovalam (post) Chennai-603 112

Tel:044-27472113,27472046 Fax:044-27472389

www.niepmd.tn.nic.in Email:niepmd@mail.com

TECHNICAL BID

(To be uploaded)

Name and address of the bidder:

1. Name of the bidder

a) Full postal address

b) Full address of the premises

c) Telegraphic address

d) Telex number

e) Telephone number

f) Fax number

2. Monthly supply capacity of goods quoted for

a) Normal

b) Maximum

3. Total average annual turn-over of last 05 FYs (value in Rupees).....
(Copy of Balance Sheet s Audit Statement / IT returns, etc. to be attached as proof)

4. Past supply details for 3 years (major orders only)

5. Whether similar job work undertaken in the past, if so details
(Samples to be displayed if required)



Customer





Quantity supplied





Year





Information to be furnished for the Technical bid for “Prosthetics & Orthotics Components & Raw Materials” for Rate Contract: -





SL NO.	NAME OF MATERIAL	PICTURE	TECHNICAL SPECIFICATION	Proposed Annual Requirement
1.	Cotton Tubular Stockinette		1. Made of fine quality (100%) cotton; 2. Skin free irritation; 3. Shrink resistant; 4. Size: 200 mm; 5. Colour: skin tone	20 Rolls (1 roll= 10 mtr.)
2.	Cotton Tubular Stockinette		1. Made of fine quality (100%) cotton; 2. Skin free irritation; 3. Shrink resistant; 4. Size: 120 mm; 5. Colour: skin tone	30 Rolls (1 roll= 10 mtr.)
3.	Cotton Tubular Stockinette		1. Made of fine quality (100%) cotton; 2. Skin free irritation; 3. Shrink resistant; 4. Size: 100mm; 5. Colour: skin tone	40 Rolls (1 roll= 10 mtr.)
4.	Cotton Tubular Stockinette		1. Made of fine quality (100%) cotton; 2. Skin free irritation; 3. Shrink resistant; 4. Size: 80mm; 5. Colour: skin tone	150 Rolls (1 roll= 10 mtr.)
5.	Cotton Tubular Stockinette		1. Made of fine quality (100%) cotton; 2. Skin free irritation; 3. Shrink resistant; 4. Size: 60mm; 5. Colour: skin tone	150 Rolls (1 roll= 10 mtr.)
6.	Cotton Tubular Stockinette		1. Made of fine quality (100%) cotton; 2. Skin free irritation; 3. Shrink resistant; 4. Size: 30mm; 5. Colour: skin tone	75 Rolls (1 roll= 10 mtr.)
7.	Cotton Tubular Stockinette		1. Made of fine quality (100%) cotton; 2. Skin free irritation; 3. Shrink resistant; 4. Size: 180mm; 5. Colour: skin tone	50 Rolls (1 roll= 10 mtr.)

8.	Cotton Tubular Stockinette		1. Made of fine quality (100%) cotton; 2. Skin free irritation; 3. Shrink resistant; 4. Size: 300mm; 5. Colour: skin tone	20 Rolls (1 roll= 10 mtr.)
9.	Nylon Tubular Stockinette		1. Made of fine quality (100%) nylon; 2. Skin free irritation; 3. up to 300% stretches; 4. Size: 200mm; 5. Colour: White	30 Rolls (1 roll= 10 mtr.)
10.	Nylon Tubular Stockinette		1. Made of fine quality (100%) nylon; 2. Skin free irritation; 3. up to 300% stretches; 4. Size: 120mm; 5. Colour: White	30 Rolls (1 roll= 10 mtr.)
11.	Nylon Tubular Stockinette		1. Made of fine quality (100%) nylon; 2. Skin free irritation; 3. up to 300% stretches; 4. Size: 100mm; 5. Colour: White	75 Rolls (1 roll= 10 mtr.)
12.	Nylon Tubular Stockinette		1. Made of fine quality (100%) nylon; 2. Skin free irritation; 3. up to 300% stretches; 4. Size: 80mm; 5. Colour: White	100 Rolls (1 roll= 10 mtr.)
13.	Nylon Tubular Stockinette		1. Made of fine quality (100%) nylon; 2. Skin free irritation; 3. up to 300% stretches; 4. Size: 60mm; 5. Colour: White	100 Rolls (1 roll= 10 mtr.)
14.	Nylon Tubular Stockinette		1. Made of fine quality (100%) nylon; 2. Skin free irritation; 3. up to 300% stretches; 4. Size: 30mm; 5. Colour: White	100 Rolls (1 roll= 10 mtr.)
15.	Plaster of Paris Bandage		1. Size: 4inch x 4.5 mtr.	600 Box (1 box= 12 nos.)
16.	Plaster of Paris Bandage		1. Size: 6inch x 4.5 mtr.	500 Box (1 box= 12 nos.)
17.	Plaster of Paris Powder		1. White colored powder; 2. Setting time: 3-5 minutes 3. Ortho Grade	1000 Kg (1 Kg packet)

18.	Fiberglass Stockinette		<ul style="list-style-type: none"> • For fabricating thin-walled laminates <ul style="list-style-type: none"> • Braiding • High torsional strength in laminates <ul style="list-style-type: none"> • Good draping characteristics <ul style="list-style-type: none"> • Size- 60 mm 	20 Rolls (10 mtr. Roll)
19.	Fiberglass Stockinette		<ul style="list-style-type: none"> • For fabricating thin-walled laminates <ul style="list-style-type: none"> • Braiding • High torsional strength in laminates <ul style="list-style-type: none"> • Good draping characteristics <ul style="list-style-type: none"> • Size- 80mm 	20 Rolls (10 mtr. Roll)
20.	Glass Fiber Cloth/ satin Type		<ol style="list-style-type: none"> 1. For partial laminate reinforcements 2. Good absorption of lamination resins 3. High strength 4. Good draping characteristics 	300Sq. Mt
21.	Carbon-Fibre Fabric		<ul style="list-style-type: none"> • For partial high-strength laminate reinforcements <ul style="list-style-type: none"> • Good absorption of lamination resins • Good draping characteristics <p>Size- Thickness- 1.5 mm</p>	250 Sq. Mt
22.	Carbon Fiber Webbing		<p>For partial high-strength, unidirectional laminate reinforcements. Large selection of different widths. Good absorption of all lamination resins</p> <p>Size- Thickness- 1.5mm; Width- 50mm</p>	20 Rolls (25 mtr. Roll)

23.	Woven Carbon-Fiberglass Stockinette		<ul style="list-style-type: none"> • For fabricating thin-walled laminates <ul style="list-style-type: none"> • Braiding • Combines the properties of carbon and fiberglass <ul style="list-style-type: none"> • Enhanced torsional strength in laminates • Torsion can be influenced by different circumferences (ideal angle 45°) <ul style="list-style-type: none"> • Size- 80mm 	25 roll (10 mtr. Roll)
24.	Polyester resin (GPR)		General Purpose Resin (Polyester Resin) for fabrication of plastic laminate prosthetic socket & plastic laminate orthosis.	100 Kg (25 kg Pkg.)
25.	Hardener (Promoters)		For General Purpose Resin (Polyester Resin)	5 Kg (1 kg pkg.)
26.	Catalyst		For General Purpose Resin (Polyester Resin)	5 Kg (1kg pkg)
27.	Epoxy Resin (Liquid)		For Fabric impregnate plastic Lamination for fabrication of plastic laminate prosthetic socket & plastic laminate orthosis	50 Kg (5 kg pkg.)
28.	Hardener		For epoxy resin	5 Kg (1 kg pkg)
29.	Pigment		Mid buff/Cinnamon/Skin colour	2 kg (½ Kg pkg.)



30.	Thinner		For softening PVC film 1 st Quality	100 liters (1 liter pkg.)
31.	Polyvinyl Chloride Film (PVC film)		1. For making PVC bag of B/K and A/K & other plastic laminate work; 2. Thickness- 0.5mm	1000 meters
32.	Insulation Tape		Poly vinyl Chloride material Color: different color	300 Pcs
33.	Vaseline/Petroleum Jelly		1. Domestic purpose; 2. Colour: Pale yellow	25 Kg (1/2 kg Packaging)
34.	Bee Wax		For making prosthetic check test socket	50 Kg (1Kg Pkg)





35.	PVA Bag for Trans Tibial and Trans radial Prosthesis lamination		Material- Polyvinyl Chloride plastic bag	500 Nos.
36.	PVA Bag for Trans Femoral and Trans Humeral and Shoulder disarticulation Prosthesis lamination		Material- Polyvinyl Chloride plastic bag	500 Nos.
37.	Sewing Thread Polyester		1. For Domestic purpose; 2. Colour: White; 3. Length: 1000 mtr.	50 Pieces/ Nos. (1 Piece- 1000 Mtr.)
38.	Hand Stitching Thread		1. Light weight Nylon or Poly Alteration Leather Thread; 2. Type: Filament Nylon or Polyester; 3. Size:46; 4. Colour: Black; 5. Length: 10,000 mtr.	50 pieces/Nos. (1 Piece- 10,000 Mtr.)
39.	Mochi Thread		For Manual stitching; Colour- Black Length- 1000 Mtr.	20 Pieces/Nos. (1 Piece- 1,000 Mtr.)
40.	Sewing Thread Cotton		1. For Domestic purpose; 2. Colour: Black; 3. Length: 10.5cm	35 Nos



	Black (Cone Type)			
41.	Sewing Thread Cotton Skin Colour (Cone Type)		1. For Domestic purpose; 2. Colour: Skin Colour; 3. Length- 1,000 Mtr.	30 Nos/Pieces (1 Piece- 1,000 Mtr.)
42.	Sewing Thread Cotton (Cylinder Type)		1. For Domestic purpose; 2. Colour: Black; 3. Length: 1000 Meter	25 Nos/Pieces (1 Piece-1,000 Mtr.)
43.	Sewing Thread Nylon (Cylinder Type)		1. For Domestic purpose; 2. Colour: White; 3. Length: 1000 Meter, bundle height- 5cm; 4. Lamination purpose	25 Nos/Pieces (1 Piece- 1,000 Mtr.)
44.	Aluminium Sheet		18 gauge Sheet size: 6feet x 4feet.	50 Sheet
45.	Aluminium Flat Bar		1. Size: Width x Thickness: 1'' x 3mm	50Mt
46.	Aluminium Flat Bar		1. Size: Width x Thickness: ¾ '' x 3mm	75Mt
47.	Aluminium Flat Bar		1. Size: Width x Thickness: ½ '' x 3mm	50Mt
48.	Aluminium Flat Bar		1. Size: Width x Thickness: 1'' x 5mm	75Mt





49.	Aluminium Flat Bar		1. Size: Width x Thickness: ¾ '' x 5mm	50Mt
50.	Cotton Webbing Strap		1. Material-Cotton; 2. Width: ½ '' ; 3. Colour: White	200 Mtr. (10 Mtr. Roll)
51.	Cotton Webbing Strap		1. Material-Cotton; 2. Width: 1'' ; 3. Colour: White	200 Mtr. (10 Mtr. Roll)
52.	Cotton Webbing Strap		1. Material -Cotton; 2. Width: 1 1/2'' ; 3. Colour: White	200 Mtr. (10 Mtr. Roll)
53.	Cotton Webbing Strap		1. Material- Cotton; 2. Width: 2'' ; 3. Colour: White	300 Mtr. (10 Mtr. Roll)
54.	Metal Buckle with Roller and Single Prong		1. Material: Metal; 2. Colour: Black/Silver; 3. Size: Length x Width x Thickness: ½ '' x 3mm	200 packet (1packet-100 Nos.)
55.	Metal Buckle with Roller and Single Prong		1. Material: Metal; 2. Colour: Black/Silver; 3. Size: Length x Width x Thickness: 1 '' x 3mm	200 packet (1packet-100 Nos.)
56.	Metal Buckle with Roller and Single Prong		1. Material: Metal; 2. Colour: Black/Silver; 3. Size: Length x Width x Thickness: 1 1/2'' x 1'' x 3mm	200 packet (1packet-100 Nos.)
57.	Metal Buckle with Roller and Single Prong		1. Material: Metal; 2. Colour: Black/Silver; 3. Size: Length x Width x Thickness: 2'' x 1 ½'' x 3mm	100 packet (1packet-100 Nos.)
58.	Metal Oval 'O' ring loop		1. Material: Metal; 2. Colour: Silver; 3. Size: Length x Width x Thickness: ½ '' x 3/8'' x 10mm	200 packet (1packet-100 Nos.)





59.	Metal Oval 'O' ring loop		1. Material: Metal; 2. Colour: Silver; 3. Size: Length x Width x Thickness: 1" x 3/8" x 10mm	200 packet (1packet-100 Nos.)
60.	Metal Oval 'O' ring loop		1. Material: Metal; 2. Colour: Silver; 3. Size: Length x Width x Thickness: 1 1/2" x 3/8" x 10mm	200 packet (1packet-100 Nos.)
61.	Metal Oval 'O' ring loop		1. Material: Metal; 2. Colour: Silver; 3. Size: Length x Width x Thickness: 2" x 3/8" x 10mm	100 packet (1packet-100 Nos.)
62.	D- Ring –Semi-circular Type		1. Welded Steel; 2. Nickel Plated; 3. Size: Inside Flat-19mm, Inside Height- 16mm, Wire Diameter- 3mm, Width-1/2 "	200 packet (1packet-100 Nos.)
63.	D- Ring –Semi-circular Type		1. Welded Steel; 2. Nickel Plated; 3. Size: Inside Flat-25mm, Inside Height- 22mm, Wire Diameter- 5mm, Width-1"	200 packet (1packet-100 Nos.)
64.	D- Ring –Semi-circular Type		1. Welded Steel; 2. Nickel Plated; 3. Size: Inside Flat- 38mm, Inside Height- 28mm, Wire Diameter- 5mm, Width-1 1/2 "	200 packet (1packet-100 Nos.)
65.	D- Ring –Semi-circular Type		1. Welded Steel; 2. Nickel Plated; 3. Size: Inside Flat- 38mm, Inside Height- 28mm, Wire Diameter- 5mm, Width-2 "	100 packet (1packet-100 Nos.)
66.	Rectangular Ring Loop		1. Welded Steel; 2. Nickel Plated; 3. Size: Length -20mm, Width- 1/2 inch, Wire Diameter- 3mm	200 packet (1packet-100 Nos.)
67.	Rectangular Ring Loop		1. Welded Steel; 2. Nickel Plated; 3. Size: Length-25mm, Width- 1 inch, Wire Diameter- 3mm	200 packet (1packet-100 Nos.)
68.	Rectangular Ring Loop		1. Welded Steel; 2. Nickel Plated; 3. Size: Length- 38mm, Width- 1 1/2 inch, Wire Diameter- 5mm	200 packet (1packet-100 Nos.)

69.	Rectangular Ring Loop		1. Welded Steel; 2. Nickel Plated; 3. Size: Length- 50mm, Width- 2 inch, Wire Diameter- 5mm	100 packet (1packet-100 Nos.)
70.	Rivet Copper flat head		1. Material: Copper; 2. Head: Flat; 3. Size: Shaft length- 13mm, Shaft Diameter-3mm (1/8'')	10 Kg
71.	Rivet Copper flat head		1. Material: Copper; 2. Head: Flat; 3. Size: Shaft length- 19mm, Shaft Diameter-3mm (1/8'')	5 Kg
72.	Rivet Copper flat head		1. Material: Copper; 2. Head: Flat; 3. Size: Shaft length- 25mm, Shaft Diameter-3mm (1/8'')	5 Kg
73.	Rivet Copper flat head		1. Material: Copper; 2. Head: Flat; 3. Size: Shaft length- 19mm, Shaft Diameter-4mm (5/32'')	10 Kg
74.	Rivet Copper flat head		1. Material: Copper; 2. Head: Flat; 3. Size: Shaft length- 25mm, Shaft Diameter-4mm (5/32'')	5 Kg
75.	Rivet Copper flat head		1. Material: Copper; 2. Head: Flat; 3. Size: Shaft length- 25mm, Shaft Diameter-4.7mm (3/16'')	6 Kg
76.	Cooper Washer		Surface Finish- Metal Coated & Electroplated Thickness- 1.5 mm Inner Diameter- 3mm Outer Diameter- 10mm	1000 Nos. (1Pkt.-200 Nos.)



77.	Cooper Washer		Surface Finish- Metal Coated & Electroplated Thickness- 1.5 mm Inner Diameter- 4mm Outer Diameter- 10mm	1000 Nos. (1Pkt.-200 Nos.)
78.	Copper Washer		Surface Finish- Metal Coated & Electroplated Thickness- 1.5 mm Inner Diameter- 5mm Outer Diameter- 12mm	1000 Nos. (1Pkt.-200 Nos.)
79.	Rivet Aluminium flat head		1. Material: Aluminium; 2. Head: Flat; 3. Size: Shaft length- 19mm, Shaft Diameter-3mm (1/8'')	20 Kg
80.	Rivet Aluminium flat head		1. Material: Aluminium; 2. Head: Flat; 3. Size: Shaft length- 25mm, Shaft Diameter-4mm (5/32'')	20 kg
81.	Press Button		1. Material: Brass; 2. Shaft Length: 6mm; 3. Colour: Black/Silver	1000 Pairs
82.	Press Button		1. Material: Brass; 2. Shaft Length: 12mm; 3. Colour: Black/Silver	1000 Pairs
83.	Press Button		1. Material: Brass; 2. Shaft Length: 19mm; 3. Colour: Black/Silver	200 Pairs
84.	Nut & Screw		1. Material: Brass; 2. Shaft Length: 3/4 inch; 3. Diameter- 1/8'' 4. Colour: Silver	1000 Nos
85.	Nut & Screw		1. Material: Brass; 2. Shaft Length: 1 inch; 3. Diameter- 1/8'' 4. Colour: Silver	1000 Nos
86.	Nut & Screw		1. Material: Brass; 2. Shaft Length: 1/2 inch; 3. Diameter- 1/8'' 3. Colour: Silver	500 Nos





87.	Nut & Screw		1. Material: Brass; 2. Shaft Length: 1/2 inch; 3. Diameter- 5/32" 3. Colour: Silver	1000 Nos.
88.	Nut & Screw		1. Material: Brass; 2. Shaft Length: 1 inch; 3. Diameter- 5/32" 3. Colour: Silver	1000 Nos.
89.	Nut & Screw		1. Material: Brass; 2. Shaft Length: 3/4 inch; 3. Diameter- 5/32" 3. Colour: Silver	1000 Nos.
90.	Nut & Bolt with Washer		1. Material: Stainless steel, 2. Shaft Length: 2 inch; 3. Diameter- 5/32" 3. Colour: Silver	500 Nos.
91.	Velcro Hook & Loop Fasteners		1. Woven Hook & Loop 2. Base Material: Nylon/ Polyester 3. Colour: Black/White 4. Size: 1/2 -inch x 25 Mtr. roll 5. Application: Orthosis/ Prosthesis	50 Rolls (1 Roll- 25 Mtr.)
92.	Velcro Hook & Loop Fasteners		1. Woven Hook & Loop 2. Base Material: Nylon/ Polyester 3. Colour: Black/White 4. Size: 1-inch x 25 Mtr. roll 5. Application: Orthosis/ Prosthesis	100 Rolls (1 Roll- 25 Mtr.)
93.	Velcro Hook & Loop Fasteners		1. Woven Hook & Loop 2. Base Material: Nylon/ Polyester 3. Colour: Black/White 4. Size: 1 1/2 -inch x 25 Mtr. roll 5. Application: Orthosis/ Prosthesis	100 Rolls (1 Roll- 25 Mtr.)
94.	Velcro Hook & Loop Fasteners		1. Woven Hook & Loop 2. Base Material: Nylon/ Polyester 3. Colour: Black/White 4. Size: 2-inch x 25 Mtr. 5. Application: Orthosis/ Prosthesis	50 Rolls (1 Roll- 25 Mtr.)





95.	PVC Rexin Cloth		<ol style="list-style-type: none"> 1. Quality- 1st Grade 2. PVC coated 3. SAE Rexine Artificial Leather Sheet Fabric 4. Colour: Black/ Skin tone 	200 meter
96.	Dendrite Adhesive		1. Dendrite PC-65 Rubber Adhesive; 2. 01 Liter packet	150 Liter (1 Liter Container)
97.	Rubber Solution- Stag Brand		1. For Leather work	50 Liter (5Liter Container)
98.	Machine Oil		For sewing Machine	5 liter (1 Liter Container)
99.	Nappa Leather for padding		Type: Vegetable tanned leather Raw Material: Cattle Hide Mas/ Skin: 4.5-6.0sqm/45-65 sqft. Thickness: 1.4- 1.6mm Tanning: Chromium –Free/ Vegetable Tensile Strength: 20N/mm Flame Resistance	200 Sq.ft.





100.	Full Grain Chrome Leather for shoe Upper		Size: 10 – 20 sqft. .Thickness: 1.3 – 1.5 mm. Selection: ABC	500 sqft.
101.	Bark Sole Leather/ Sole Leather /Vegetable Tanned Leather		<ol style="list-style-type: none"> 1. Thickness: 3-4mm 2. Material- Buffalo Leather 	75 Kg
102.	Suede Leather		<ol style="list-style-type: none"> 1. Size of skin: 3- 5 sq ft 2. Thickness of skin: 0.5/0.6mm 3. Grain type: Natural Grain 4. For Shoe making; 2. Colour: Different Colour 	500 Sqft
103.	Lining Leather		<ol style="list-style-type: none"> 1. Type- Full Grain chrome free, 2. Thickness- 0.9 to 1.1 mm 3. Tensile Strength- 20 N/m, 4. For Shoe Making; 2. Colour: Skin Tone/ Brown 	500 sqft
104.	Kattai Leather		<ol style="list-style-type: none"> 6. Thickness: 1.5- 1.8mm; 2. Colour: Black/Brown 3. Used for making MCR Chappal, Suspension System 	45 Kg



105.	Leather Board		1. Size: ½ meter x ½ meter x 3mm	15 Nos.
106.	Shoe Lace/Shoe Strings (Round)		1. Material: Cotton Blends, Polyester; 2. Pattern: Pure; 3. Style: Round lace; 4. Colour: Black; 5. Size (Length x Width): 32'' x 0.4''	150 pairs
107.	Shoe Lace/Shoe Strings (Round)		1. Material: Cotton Blends, Polyester; 2. Pattern: Pure; 3. Style: Round lace; 4. Colour: Black; 5. Size(Length x Width): 24'' x 0.4''	150 pairs
108.	Shoe Lace/Shoe Strings (Round)		1. Material: Cotton Blends, Polyester; 2. Pattern: Pure; 3. Style: Round lace; 4. Colour: Brown; 5. Size (Length x Width): 32'' x 0.4''	150 pairs
109.	Shoe Lace/Shoe Strings (Round)		1. Material: Cotton Blends, Polyester; 2. Pattern: Pure; 3. Style: Round lace; 4. Colour: Brown; 5. Size(Length x Width): 24'' x 0.4''	150 pairs
110.	Shoe Lace/Shoe Strings (Flats)		1. Material: Cotton Blends, Polyester; 2. Pattern: Pure; 3. Style: Flat lace; 4. Colour: Brown; 5. Size(Length x Width): 32'' x 0.4''	150 pairs
111.	Eyelets for shoe		1. Material: Metal; 2. Size: Large; 3. Colour: Black	1000 nos.
112.	Eyelets for shoe		1. Material: Metal; 2. Size: Medium; 3. Colour: Black	1000 nos.
113.	Eyelets for shoe		1. Material: Metal; 2. Size: Large; 3. Colour: Silver	1000 nos.

114.	Eyelets for shoe		1. Material: Metal; 2. Size: Large; 3. Colour: Silver	1000 nos.
115.	Shoe Polish- Kiwi/ Cherry Brand		1. Colour: Black; 2. Wax Polish; 3. 40 gm Pkt.	50 nos.
116.	Shoe Polish- Kiwi/ Cherry Brand		1. Colour: Brown; 2. Wax Polish; 3. 40 gm Pkt.	50 nos.
117.	Nigrosine (Polish) Powder		Material Type Wool,Silk,Nylon,Fur,Feathers Types Strong Form Powder, Liquid, Granules Color Black	05 kg (250 g pkt.)
118.	Shoe Polish Brush		1. Soft bristles; 2. Wooden Base; 3. Size(Length x Width x Height): 8.25'' x 2.5'' x 2.25''	25 nos.
119.	Shoe Polish Brush		1. Soft bristles; 2. Wooden Base; 3. Size(Length x Width x Height): 6.25'' x 2.5'' x 2.25''	25 nos.
120.	Shoe Tacks		1. For Shoe making; 2. Material: Iron; 3. Finished: Blue; 4. Flat & round cap, square shaft; 5. Size: 13mm	20 Kg (1 Kg Pkt.)

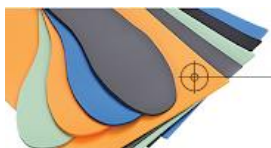

121.	Shoe Tacks		1. For Shoe making; 2. Material: Iron; 3. Finished: Blue; 4. Flat & round cap, square shaft; 5. Size: 20mm	20 Kg(1 Kg Pkt.)
122.	Leather Shoe Welt		1. Material: Cow Skin; 2. Type: Grain; 3. Thickness: 2mm; 4. Width: 1 cm 5. Pattern: Finished	100 Pcs
123.	Shoe Out sole Sheet		1.Pyramid Pattern Anti-Slip Rubber Mat; 2. Material: Natural Rubber/ SBR; 3. Colour: Black; 4. Size (L x Wx T): 1.5 mtr. x1.5 mtr. X 13mm	25 Sheet
124.	Men Chappal/Sandal Outer sole		Material PVC, Colour- Black, Size – 5 Adult	15 Pairs
125.	Mens Chappal/Sandal Outer sole		Material PVC, Colour- Black, Size – 6 Adult	15 Pairs
126.	Mens Chappal/Sandal Outer sole		Material PVC, Colour- Black, Size – 7 Adult	15 Pairs
127.	Mens Chappal/Sandal Outer sole		Material PVC, Colour- Black, Size – 8 Adult	15 Pairs
128.	Mens Chappal/Sandal Outer sole		Material PVC, Colour- Black, Size – 9 Adult	15 Pairs

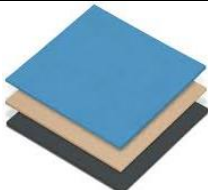
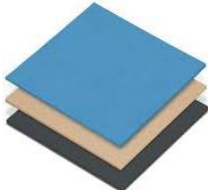





129.	Mens Chappal/Sandal Outer sole		Material PVC, Colour- Black, Size – 10 Adult	15 Pairs
130.	PU adhesive		Dendrite PU Adhesive (01 Litre packet)	15 Liter
131.	PU Adhesive Hardener		PU Hardener	5 Liter
132.	Rubber Ferrule-SQUARE TYPE		For Auxiliary/ Elbow Crutch Tip 1''	100 Pcs
133.	Rubber Ferrule-SQUARE TYPE		For Auxiliary/ Elbow Crutch Tip $\frac{3}{4}$ ''	100 Pcs
134.	Rubber Ferrule-ROUND TYPE		For Auxiliary/ Elbow Crutch tip 1''	250 Pcs
135.	Rubber Ferrule-ROUND TYPE		For Auxiliary/ Elbow Crutch tip $\frac{3}{4}$ ''	250 Pcs
136.	Light Weight sole Raising Sheet (Shalimar)		1. Size (L x W x T): 1.5 mtr. X 1 mtr. 13mm	30 nos.



137.	Light Weight sole Raising Sheet (Shalimar)		1. Size (L x W x T): 1.5 mtr. X 1 mtr. 25mm	55 nos.
138.	Light Weight sole Raising Sheet (Shalimar)		1. Size (L x W x T): 1.5 mtr. X 1 mtr. 50mm	30 nos.
139.	MCR Sole Sheet-FOR DIABETIC FOOT WEAR		1. Micro Cellular Rubber; 2. Size (L x W x T): 20 INCH X 24INCH X 10MM, 3. Colour: Black ,3. shore hardness of 15' Shore 'A'	50 Sheets
140.	MCR Sole Sheet-FOR DIABETIC FOOT WEAR		2. Micro Cellular Rubber; 2. Size (L x W x T) : 20 INCH X 24INCH X 10MM 3. Colour: Brown,3.shore hardness of 15' Shore 'A'	50 Sheets.
141.	MCP (Micro Cellular Polymer)/ EVAZOTE/ PORON 96		5. Sheet Size: 1Mtr. X 2Mtr.x 6mm 6. Colour: Different Colour	50 Sheets
142.	MCP (Micro Cellular Polymer)/ EVAZOTE/ PORON 4000		1. Sheet Size: 1Mtr. X 2Mtr.x 3mm 2. Colour: Different Colour	40 Sheets
143.	EVA foam/ Ethaflex Sheet		1. Size (L x W x T): 1.5 mtr. X 1 mtr. X 1.5 mm; 2. Colour: Different types	75 Sheets
144.	EVA foam/ Ethaflex Sheet		1. Size (L x W x T): 1.5 mtr. X 1 mtr. X 2 mm; 2. Colour: Different types	75 Sheets



145.	EVA foam/ Ethaflex Sheet		1. Size (L x W x T): 1.5 mtr. X 1 mtr. X 3 mm; 2. Colour: Different types	100 Sheets
146.	EVA foam/ Ethaflex Sheet		1. Size (L x W x T): 1.5 mtr. X 1 mtr. X 4 mm; 2. Colour: Different types	75 Sheets
147.	EVA foam/ Ethaflex Sheet		1. Size (L x W x T): 1.5 mtr. X 1 mtr. X 5 mm; 2. Colour: Different types	75 Sheets
148.	Pelite for soft prosthetic Socket		Length *Width= 5 Sq. Mt Thickness=3mm Colour= Brown/ skin tone	30 Sheets
149.	Pelite for soft prosthetic Socket		Length *Width= 5 Sq. Mt Thickness=4mm Colour= Brown/ skin tone	50 Sheets
150.	Plastazote		Length *Width= 5 Sq. Mt Thickness=2mm, 4mm Colour: Different types	20 Sheets each
151.	Aliplast		Length *Width= 5 Sq. Mt Thickness=2mm, 4mm	20 Sheets

152.	Aliplast		Length *Width= 5 Sq. Mt Thickness= 4mm	20 Sheets
153.	PU Foam Ankle Block		Density: 400 plus or minus 5Kg/m3 Size: 1Mtr x ½ mtr x 125mm	20 Nos
154.	PU Foam Socket Block		Density: 180 plus or minus 5Kg/m3 Size: 1Mtr x ½ mtr x 230 mm	20 Nos
155.	Cork Sheet		Thickness: -12mm Length * Width=1meter /1/2 meter	10 Sheet
156.	Cork Sheet		Thickness: 25 mm Length * Width=1meter /1/2 meter	50 Sheet
157.	Foot Impression Block		For taking foot impression of neuropathic foot and other foot deformity Material: PU Foam Size: Standard	200 Pairs
158.	Split Pin- Heavy Duty		1. Brass Plated Steel Pin; 2. Colour: Silver; 3. Size: Shaft length-12 mm; 4. Head: Flat, circular	1000 nos.
159.	Split Pin- Heavy Duty		1. Brass Plated Steel Pin; 2. Colour: Silver; 3. Size: Shaft length-19 mm; 4. Head: Flat, circular	500 nos.
160.	Split Pin- Heavy Duty		1. Brass Plated Steel Pin; 2. Colour: Silver; 3. Size: Shaft length-25 mm; 4. Head: Flat, circular	300 nos.



161.	Prosthetic Button with Hole		Used as suspensor fastner in lower extremity prosthesis Material: Copper Made	100 Nos.
162.	Heavy Duty Cotton Cloth (Canvas) (Dark Maroon for Gaiter)		<ol style="list-style-type: none"> 1. for making gaiter: Colour- Different types 2. Size: (L*B) 50mt *1 Mt 3. Material: Heavy Duty Canvas Cloth (Thick Fabric) 4. GSM: 200 5. Weave Type: Plain Woven Fabric 6. Material: 100 % Cotton 	50 Roll (1 Roll- 50 Mtr.)
163.	Emery Paper/ Sanding Paper		1. Size:4 Inches wide; 2. Grit: 320 (Smooth)	10 Rolls (1 Roll- 5 Mtr.)
164.			1. Size:4 Inches wide; 2. Grit: 180 (Smooth	10 Rolls (1 Roll- 5 Mtr.)
165.			1. Size: 4 inches; 2. Grit: 120 (Smooth)	10 Rolls (1 Roll- 5 Mtr.)
166.			1. Size: 4 inches ; 2. Grit: 100(smooth)	20 Rolls (1 Roll- 5 Mtr.)
167.			1. Size: 4''; 2. Grit: 80 (Rough)	25 Rolls (1 Roll- 5 Mtr.)
168.			1. Size: 4'' ; 2. Grit: 60 (Rough)	15 Rolls (1 Roll- 5 Mtr.)





169.	Hacksaw Blade		1. Material: HSS; 2. Size (Length x Width x Thickness): 300 x 25x 1.25mm; 3. Double side teeth	5 Pkt. (1 Pkt.- 10 Nos.)
170.	Elastic Strap/Band		1. Woven Surgical Elastic; 2. Heat & chemical resistant; 3. Colour: Sin Tone 4. Size: 4''	25 Roll (1 Roll- 5 Mtr.)
171.	Elastic Strap/Band		1. Woven Surgical Elastic; 2. Heat & chemical resistant; 3. Colour: Sin Tone 4. Size: 6''	25 Roll (1 Roll- 5 Mtr.)
172.	Copying Pencil		1. Colour: Violet/Blue	50 Pkt. (1 Pkt.- 10 Nos.)
173.	Glass Marking Pencil		1. Colour: Black/Orange	20 Pkt. (1 Pkt.- 10 Nos.)
174.	Glass Marking Pencil		1. Colour: White	15 Pkt. (1 Pkt.- 10 Nos.)
175.	Surform Blade- Stanley Made		1. Material: Metal; 2. Type: Flat; 3. Cut: Standard	50 nos.
176.	Surform Blade- Stanley Made		1. Material: Metal; 2. Type: Half Round; 3. Cut: Standard	50 nos.

177.	Surform Blade- Stanley Made		1. Material: Metal; 2. Type: Round; 3. Cut: Standard	50 nos.
178.	Twist/ Spiral Drill Bit		1. Material: High Speed Steel; 2. Size: 1/8''	50 nos.
179.	Twist/ Spiral Drill Bit		1. Material: High Speed Steel; 2. Size: 5/32''	50 nos.
180.	Twist/ Spiral Drill Bit		1. Material: High Speed Steel; 2. Size: 1/4''	50 nos.
181.	Twist/ Spiral Drill Bit		1. Material: High Speed Steel; 2. Size: 7/32''	30 nos.
182.	Twist/ Spiral Drill Bit		1. Material: High Speed Steel; 2. Size: 3/16''	50 nos.
183.	Zig Saw Blade		1. Bosch- T123X HSS; 2. Material: BIM; 3. Tooth Design: Side set, milled; 4. Total Length: 100mm; 5. Tooth Spacing: 1.2-2.6mm	30 nos.
184.	Zig Saw Blade- Bosch made		1. Bosch-T244D HCS; 2. Material: high carbon steel; 3. Tooth Design: Side set, milled; 4. Total Length: 100mm; 5. Tooth Spacing: 4-5.2mm; 6. Length of teeth: 74mm	30 nos.
185.	Zig Saw Blade- Bosch Made		1. Bosch-T144D HCS; 2. Material: high carbon steel; 3. Tooth Design: Side set, ground; 4. Total Length: 100mm; 5. Tooth Spacing: 4-5.2mm; 6. Length of teeth: 74mm	30 nos.













186.	Polystyrene		Thickness: 10mm Size: 2 Mtr. X 1 Mtr.	10 Nos.
187	Polystyrene		Thickness: 12 mm Size: 2 Mtr. X 1 Mtr.	10 Nos
188	Polypropylene Orthograde Sheet		Material: Ortho- 'P'- 'RC'- Weight bearing Colour: Natural Size of sheet: 1 Mtr (Width) x 2 Mtr(Length) Thickness: 4mm Quality: Premium	50 Sheets
189	Polypropylene Orthograde Sheet		Material: Ortho- 'Ortho- 'Flex' Non Weight bearing Colour: Natural Size of sheet: 1 Mtr (Width) x 2 Mtr(Length) Thickness: 3 mm Quality: Premium	50 Sheets
190	Polypropylene Orthograde Sheet		Material: Ortho- 'P'- 'RC'- Weight bearing Colour: Natural Size of sheet: 1 Mtr (Width) x 2 Mtr(Length) Thickness: 6mm Quality: Premium	50







191	Polypropylene Orthograde Sheet		Material: Ortho- 'P'- 'RC'- Weight bearing Colour: Natural Size of sheet: 1 Mtr (Width) x 2 Mtr(Length) Thickness: 12mm Quality: Premium	30 heets
192	Polypropylene Orthograde Sheet		Material: Ortho- 'P'- 'RC'- Weight bearing Colour: Natural Size of sheet: 1 Mtr (Width) x 2 Mtr(Length) Thickness: 15mm Quality: Premium	30 Sheets
193	Polyethylene Sheet		Thickness=3mm Length*Width=1.22mt*2.44mt Colour: Natural	20 heets
194	Polyethylene Sheet		Thickness= 4mm Length*Width=1.22mt*2.44mt Colour: Natural	20 Sheets
195	LTTP Sheet (Low temperature thermoplastic)		Thickness= 4mm Length*width=1 mtr x 1 mtr Quality: Porous Colour: Skin Tone	20 heets
196	Copolymer Plastic Sheet	Used for Fabrication of Prosthetic Socket and Lower extremity Orthosis	Material: blend of Polypropylene and polyethylene Colour: Natural Size: 2 Mtr (Length) x 1 Mtr (Width) Thickness: 12 mm	20 Sheets

MODULAR BELOW KNEE (BK/TT) PROSTHETIC KIT WITHOUT PROSTETIC FOOT- STAINLESS STEEL MADE					
197	BK/TT Prosthetic kit (For Plastic Lamination)	Kit Components: - Male Socket Adaptor (Pyramid Type)- 01 No.; Female Tube Clamp Adaptor- 01 Nos.; Pylon with female adapter- 01 No.; Foot Adapter with Bolt- 01 No.; Prosthetic Button with Hole (Copper Made)- 04 Nos.; Cosmetic Stocking (Skin Tone)- 02 Nos. Total Components= 10 Nos. MATERIAL= STAINLESS STEEL; WEIGHT BEARING CAPACITY- UP TO 120 Kg.			25 Nos.
198	BK/TT Prosthetic kit (For Plastic Drape)	Kit Components: - Male Socket Adaptor (Pyramid Type)- 01 No.; Female Tube Clamp Adaptor- 01 Nos.; Pylon with female adapter- 01 No.; Foot Adapter with Bolt- 01 No.; Prosthetic Button with Hole (Copper Made)- 04 Nos.; Cosmetic Stocking (Skin Tone)- 02 No. Total Components= 10 Nos. MATERIAL= STAINLESS STEEL; WEIGHT BEARING CAPACITY- UP TO 120 Kg.			125 Nos.
DESCRIPTION DETAILS OF BK/TT PROSTHETIC KITS- STAINLESS STEEL MADE					
			Plastic Lamination Type	Plastic Drape Type	
	Male socket adaptor (Pyramid type)	01 Nos. 			
	Female tube clamp adapter	01 Nos. 			
	Pylon with female adapter	01 No. 			

<p>Foot Adapter with Bolt</p>	<p>01 No.</p> 			
<p>Prosthetic Button with Hole</p>	 <p>04 Nos.</p>			
<p>Cosmetic Stocking (Skin Tone)- 02 Nos</p>	 <p>02 Nos.</p>			



MODULAR BELOW KNEE (BK/TT) PROSTHEITC KIT WITHOUT PROSTHETIC FOOT-ALUMINIUM MADE







199	BK/TT Prosthetic kit (For Plastic Lamination)	<p>Kit Components: - Male Socket Adaptor (Pyramid Type)- 01 No.; Female Tube Clamp Adaptor- 01 Nos.; Pylon with female adapter- 01 No.; Foot Adapter with Bolt- 01 No.; Prosthetic Button with Hole (Copper Made)- 04 Nos.; Cosmetic Stocking (Skin Tone)- 02 Nos.</p> <p>Total Components= 10 Nos.</p> <p>MATERIAL= ALUMINIUM ; WEIGHT BEARING CAPACITY- UP TO 100 Kg.</p>	25 Nos.		
200	BK/TT Prosthetic kit (For Plastic Drape)	<p>Kit Components: - Male Socket Adaptor (Pyramid Type)- 01 No.; Female Tube Clamp Adaptor- 01 Nos.; Pylon with female adapter- 01 No.; Foot Adapter with Bolt- 01 No.; Prosthetic Button with Hole (Copper Made)- 04 Nos.; Cosmetic Stocking (Skin Tone)- 02 No.</p> <p>Total Components= 10 Nos.</p> <p>MATERIAL= ALUMINIUM ; WEIGHT BEARING CAPACITY- UP TO 100 Kg.</p>	75 Nos.		
DESCRIPTION DETAILS OF BK/TT PROSTHETIC KITS- ALUMINIUM MADE					
		Plastic Lamination Type	Plastic Drape Type		
	Male socket adaptor	01 No. 			
	Female tube clamp adaptor	 01 No.			
	Pylon with female adapter	01 No. 			
	Foot Adapter with Bolt	01 Nos. 			

	Prosthetic Button with Holes	 04 Nos.	 		
	Cosmetic Stocking (Skin Tone)- 02 Nos	 02 Nos.	 		
201	Sleeve suspension for Below knee(BK/TT) Prosthesis				100NOS,
202	Stump Sock for Below knee(BK/TT) Prosthesis				100 Nos.
MODULAR ABOVE KNEE (AK/TF) PROSTHETIC KIT WITHOUT PROSTHETIC FOOT- STAINLESS STEEL					
203	AK/TF PROSTHETIC KIT – PLASTIC DRAPE TYPE	Kit Components: - AK Socket Adaptor with Pyramid Receiver - 01 No.; Four –Bar Polycentric Knee Joint- 01 No.; Tube Clamp Adaptor- 01 No.; Pylon with integrated tube Adaptor- 01 No.; Foot Adapter with Bolt- 01 No.; Prosthetic Button with Hole (Copper Made)- 04 Nos.; Cosmetic Stocking (Skin Tone)- 02 Nos.; Cosmetic PU Foam Covering- 01 No. Total Components= 12 Nos.			25 Nos.

		MATERIAL= STAINLESS STEEL ; WEIGHT BEARING CAPACITY- UP TO 120 Kg.	
204	AK/TF PROSTHETIC KIT – PLASTIC LAMINATE TYPE	Kit Components: - Three Prong AK Socket Adaptor with Rotatable Receiver - 01 No.; Four –Bar Polycentric Knee Joint- 01 No.; Tube Clamp Adaptor- 01 Nos.; Pylon with integrated tube Adaptor- 01 No.; Foot Adapter with Bolt- 01 No.; Prosthetic Button with Hole (Copper Made)- 04 Nos.; Cosmetic Stocking (Skin Tone)- 02 Nos.; Cosmetic PU Foam Covering- 01 No. Total Components= 12 Nos. MATERIAL= STAINLESS STEEL ; WEIGHT BEARING CAPACITY- UP TO 120 Kg.	50 Nos.
205	AK/TF PROSTHETIC KIT – PLASTIC LAMINATE TYPE	Kit Components: - Three Prong AK Socket Adaptor with Rotatable Receiver - 01 No.; Four –Bar Polycentric Knee Joint with Integrated tube bar adaptor- 01 No.; Pylon with integrated tube Adaptor- 01 No.; Foot Adapter with Bolt- 01 No.; Prosthetic Button with Hole (Copper Made)- 04 Nos.; Cosmetic Stocking (Skin Tone)- 02 Nos.; Cosmetic PU Foam Covering- 01 No. Total Components= 11 Nos. MATERIAL= STAINLESS STEEL ; WEIGHT BEARING CAPACITY- UP TO 120 Kg.	50 Nos.

DESCRIPTION OF AK/TF PROSTHETIC KITS











			Plastic Drape Type	Plastic Lamination Type
	AK socket Adaptor with Pyramid Receiver	 01 No.	Yes	No
	Socket Adaptor 3 Prong- Pyramid Type	 01 No.	NO	Yes



<p>Four- Bar Polycentric Knee Joint</p>	 01 No.	<p>Yes</p>	<p>Yes</p>
<p>Female tube clamp adapter</p>	 01 No.	<p>Yes</p>	<p>Yes</p>
<p>Pylon with Integrated Tube adapter</p>	 01 No	<p>Yes</p>	<p>Yes</p>
<p>Foot Adaptor with Bolt</p>	 01 No.	<p>Yes</p>	<p>Yes</p>
<p>Prosthetic Button with hole</p>	 04 Nos.	<p>Yes</p>	<p>Yes</p>
<p>Cosmetic Stocking</p>	 02 Nos.	<p>Yes</p>	<p>Yes</p>







THROUGH KNEE DISARTICULATION(KD/TH) PROSTHETIC KIT- STAINLESS STEEL MADE

206	KD/TH PROSTHETIC KIT – PLASTIC LAMINATE TYPE	Kit Components: - Modular Four Bar Polycentric Knee Joint with socket adaptor- 01 No.; Pylon with integrated tube Adaptor- 01 No.; Foot Adaptor with Bolt- 01 No.; Prosthetic Button with Hole (Copper Made)- 04 Nos.; Cosmetic Stocking (Skin Tone)- 02 Nos.; Total Components= 9 Nos. MATERIAL= STAINLESS STEEL ; WEIGHT BEARING CAPACITY- UP TO 120 Kg.	20 Nos.
-----	---	---	---------

DESCRIPTION OF PLASTIC LAMINATION TYPE KD/TH PROSTHEITC KIT

Modular Four Bar Polycentric Knee Joint with socket adaptor	 01 No.				
Female tube clamp adapter	 01 No.				
Pylon with Integrated Tube adapter	 02 No				
Foot Adaptor with Bolt	 01 No.				
Prosthetic Button with hole	 04 Nos.				







	Cosmetic Stocking	 02 Nos.			
207	Total Elastic Suspension (TES) for Above Knee (AK/TF) prosthesis (Right/Left)				100 Nos.
MODULAR HIP DISARTICULATION (HD) PROSTHETIC KIT WITHOUT PROSTHETIC FOOT- STAINLESS STEEL MADE					
208	HD PROSTHETIC KIT – PLASTIC LAMINATE TYPE	Kit Components: - Modular Polycentric Hip Joint with Integrated tube bar adaptor and socket adaptor- 01 No.; Proximal Pylon with integrated tube Adaptor- 01 No.; Four bar polycentric knee joint-01 Nos.; Female tube clamp adapter-01 Nos.; Pylon with integrated ankle adapter-01 Nos.; Foot Adapter with Bolt- 01 No.; Prosthetic Button with Hole (Copper Made)- 04 Nos.; Cosmetic Stocking (Skin Tone)- 02 Nos. Total Components= 12 Nos. MATERIAL= STAINLESS STEEL ; WEIGHT BEARING CAPACITY- UP TO 120 Kg.			15 Nos.
MODULAR HIP DISARTICULATION (HD) PROSTHETIC KIT WITHOUT PROSTHETIC FOOT DESCRIPTION DETAILS					
	Modular Polycentric Hip Joint with Integrated tube bar adaptor and socket adaptor	 01 No.			
	Proximal pylon tube with integrated tube bar adaptor	 01 No.			





	Four-bar prosthetic knee	01 No. 				
	Female tube clamp adapter	01 No. 				
	Pylon with integrated ankle adapter	01 No. 				
	Foot Adapter with bolt	01 No. 				
	Prosthetic Button with Hole	 04 Nos.				
	Cosmetic Stocking	 02 Nos.				
209	Ranger Foot Slim 22 cm Right Wooden Keel , Colour- Skin Texture, Material- Polyurethane, Internal KEEL- Wooden (Injection Molding,, Separate Great toe, Weight Limit- 100 Kg., Nut and Bolt assembly)				10 Nos.	
210	Ranger Foot Slim 22 cm Left Wooden Keel , Colour- Skin Texture, Material- Polyurethane, Internal KEEL- Wooden (Injection Molding,, Separate Great toe, Weight Limit- 100 Kg., Nut and Bolt assembly)				10 Nos.	
211	Ranger Foot Slim 23cm Right Wooden Keel , Colour- Skin Texture, Material- Polyurethane, Internal KEEL- Wooden (Injection Molding,, Separate Great toe, Weight Limit- 100 Kg., Nut and Bolt assembly)				10 Nos.	

212	Ranger Foot Slim 23cm Left Wooden Keel , Colour- Skin Texture, Material- Polyurethane, Internal KEEL- Wooden (Injection Molding,, Separate Great toe, Weight Limit- 100 Kg., Nut and Bolt assembly)	10 Nos.
213	Ranger Foot Slim 24cm Right Wooden Keel , Colour- Skin Texture, Material- Polyurethane, Internal KEEL- Wooden (Injection Molding,, Separate Great toe, Weight Limit- 100 Kg., Nut and Bolt assembly)	10 Nos.
214	Ranger Foot Slim 24cm Left Wooden Keel , Colour- Skin Texture, Material- Polyurethane, Internal KEEL- Wooden (Injection Molding,, Separate Great toe, Weight Limit- 100 Kg., Nut and Bolt assembly)	10 Nos.
215	Ranger Foot Slim 25cm Right Wooden Keel , Colour- Skin Texture, Material- Polyurethane, Internal KEEL- Wooden (Injection Molding,, Separate Great toe, Weight Limit- 100 Kg., Nut and Bolt assembly)	10 Nos.
216	Ranger Foot Slim 25 cm Left Wooden Keel , Colour- Skin Texture, Material- Polyurethane, Internal KEEL- Wooden (Injection Molding,, Separate Great toe, Weight Limit- 100 Kg., Nut and Bolt assembly)	20 Nos.
217	Ranger Foot Slim 26 cm Right Wooden Keel , Colour- Skin Texture, Material- Polyurethane, Internal KEEL- Wooden (Injection Molding,, Separate Great toe, Weight Limit- 100 Kg., Nut and Bolt assembly)	20 Nos.
218	Ranger Foot Slim 26 cm Left Wooden Keel , Colour- Skin Texture, Material- Polyurethane, Internal KEEL- Wooden (Injection Molding,, Separate Great toe, Weight Limit- 100 Kg., Nut and Bolt assembly)	30 Nos.
219	Ranger Foot Slim 27 cm Right Wooden Keel , Colour- Skin Texture, Material- Polyurethane, Internal KEEL- Wooden (Injection Molding,, Separate Great toe, Weight Limit- 100 Kg., Nut and Bolt assembly)	30 Nos.
220	Ranger Foot Slim 27cm Left Wooden Keel , Colour- Skin Texture, Material- Polyurethane, Internal KEEL- Wooden (Injection Molding,, Separate Great toe, Weight Limit- 100 Kg., Nut and Bolt assembly)	30 Nos.
221	Ranger Foot Slim 28 cm Right Wooden Keel , Colour- Skin Texture, Material- Polyurethane, Internal KEEL- Wooden (Injection Molding,, Separate Great toe, Weight Limit- 100 Kg., Nut and Bolt assembly)	30 Nos.
222	Ranger Foot Slim 28 cm Left Wooden Keel , Colour- Skin Texture, Material- Polyurethane, Internal KEEL- Wooden (Injection Molding,, Separate Great toe, Weight Limit- 100 Kg., Nut and Bolt assembly)	25 Nos.

223	Ranger Foot Slim for child (12 & 13 cm) Wooden Keel , Colour- Skin Texture, Material- Polyurethane, Internal KEEL- Wooden (Injection Molding,, Separate Great toe, Weight Limit- 35 Kg., Nut and Bolt assembly)	25 Nos.
224	Jaipur Foot Various sizes with ankle bolt	50 Nos.
225	Jaipur foot various Sizes without ankle bolt	50 Nos.
BODY POWERED BELOW ELBOW (BE/TR) PROSTHETIC KIT		
226	BE/TR PROSTHETIC KIT – ADULT – RIGHT Kit Components: - Mechanical Hand (VO Type)- 01 No.; Cosmetic hand gloves- 01 No.; Quick Disconnect Wrist Unit- 01 No.; Harness System- Figure-8-Type - 01 Nos.; Single Control Cable with Cable Housing kit (with all necessary accessories - 01 No. Total Components= 05 Nos. Material: Stainless steel/ Mild Steel/ Aluminum & High Quality Fabric(Cotton/Nylon	50 Nos.
227	BE/TR PROSTHETIC KIT – ADULT – LEFT Kit Components: - Mechanical Hand (VO Type)- 01 No.; Cosmetic hand gloves- 01 No.; Quick Disconnect Wrist Unit- 01 No.; Harness System- Figure-8-Type - 01 Nos.; Single Control Cable with Cable Housing kit (with all necessary accessories - 01 No. Total Components= 05 Nos. Material: Stainless steel/ Mild Steel/ Aluminum & High Quality Fabric(Cotton/Nylon)	35 Nos.
228	BE/TR PROSTHETIC KIT – CHILD – RIGHT Kit Components: - Mechanical Hand (VO Type)- 01 No.; Cosmetic hand gloves- 01 No.; Quick Disconnect Wrist Unit- 01 No.; Harness System- Figure-8-Type - 01 Nos.; Single Control Cable with Cable Housing kit (with all necessary accessories - 01 No. Total Components= 05 Nos. Material: Stainless steel/ Mild Steel/ Aluminum & High Quality Fabric(Cotton/Nylon)	20 Nos.
229	BE/TR PROSTHETIC KIT –CHILD – LEFT Kit Components: - Mechanical Hand (VO Type)- 01 No.; Cosmetic hand gloves- 01 No.; Quick Disconnect Wrist Unit- 01 No.; Harness System- Figure-8-Type - 01 Nos.; Single Control Cable with Cable Housing kit (with all necessary accessories - 01 No. Total Components= 05 Nos. Material: Stainless steel/ Mild Steel/ Aluminum & High Quality Fabric (Cotton/Nylon)	15 Nos.



DESCRIPTION OF BODY POWERED BELOW ELBOW (BE/TR) PROSTHETIC KIT







<p>Mechanical Hand (VO) with Rubberized Cover</p>	 <p>01 No.</p>		
<p>Cosmetic Glove-Skin Shade</p>	 <p>01 No.</p>		
<p>Quick Disconnect Wrist Unit</p>	 <p>01 No.</p>		
<p>Harness System-Figure-8-Type</p>	 <p>01 No.</p>		
<p>Single Control Cable system with housing</p>	 <p>01 No.</p>		



	Base Plate Retainer set	 01 No.		
	Cross Bar Assembly	 01 Set		
	Cable to TD Adaptor	 01 Set		
	Hanger	 01 No.		
BODY POWERED ABOVE ELBOW (AE/TH) PROSTHETIC KIT				
230	AE/TH PROSTHETIC KIT – ADULT – RIGHT	Kit Components: - Manually operated Mechanical Elbow Joint – 01 No.; Mechanical Hand (VO Type)- 01 No.; Cosmetic hand gloves- 01 No.; Quick Disconnect Wrist Unit- 01 No.; Harness System- Figure-8-Type with all necessary strap- 01 No.; Forearm Lift Lever Loop- 01 No.; Dual Control Cable with Cable Housing kit (with all necessary accessories - 01 No. Total Components= 07Nos. Material: Stainless steel/ Mild Steel/ Aluminum & High Quality Fabric(Cotton/Nylon)/Leather		50 Nos.
231	AE/TH PROSTHETIC KIT – ADULT – LEFT	Kit Components: - Manually operated Mechanical Elbow Joint – 01 No; Mechanical Hand (VO Type)- 01 No.; Cosmetic hand gloves- 01 No.; Quick Disconnect Wrist Unit- 01 No.; Harness System- Figure-8-Type with all necessary strap - 01 No; Forearm Lift Lever Loop- 01 No; Dual Control Cable with Cable Housing kit (with all necessary accessories - 01 No.		40 Nos.

		Total Components= 07 Nos. Material: Stainless steel/ Mild Steel/ Aluminum & High Quality Fabric(Cotton/Nylon)/Leather	
232	AE/TH PROSTHETIC KIT –CHILD – RIGHT	Kit Components: - Manually operated Mechanical Elbow Joint – 01 No; Mechanical Hand (VO Type)- 01 No.; Cosmetic hand gloves- 01 No.; Quick Disconnect Wrist Unit- 01 No.; Harness System- Figure-8-Type with all necessary strap - 01 No.; Forearm Lift Lever Loop- 01 No; Dual Control Cable with Cable Housing kit (with all necessary accessories - 01 No. Total Components= 07 Nos. Material: Stainless steel/ Mild Steel/ Aluminum & High Quality Fabric(Cotton/Nylon)/Leather	20 Nos.
233	AE/TH PROSTHETIC KIT – CHILD – LEFT	Kit Components: - Manually operated Mechanical Elbow Joint – 01 No; Mechanical Hand (VO Type)- 01 No.; Cosmetic hand gloves- 01 No.; Quick Disconnect Wrist Unit- 01 No.; Harness System- Figure-8-Type with all necessary strap - 01 No.; Forearm Lift Lever Loop- 01 No; Dual Control Cable with Cable Housing kit (with all necessary accessories - 01 No. Total Components= 07 Nos. Material: Stainless steel/ Mild Steel/ Aluminum & High Quality Fabric(Cotton/Nylon)/Leather	15 Nos.



DESCRIPTION OF AE/TH BODY POWERED PROSTHESIS

Internal Locking Mechanical Elbow Unit	 01 No.	
Forearm lift lever loop	 01 No.	
Mechanical Hand with Rubberized Cover (VO)	 01 No.	

<p>Cosmetic Glove- Skin Shade</p>	 <p>01 No.</p>		
<p>Quick Disconnect Wrist Unit</p>	 <p>01No.</p>		
<p>Harness System- Figure-8- type</p>	 <p>01 No.</p>		
<p>Dual Control Cable with housing</p>	 <p>01 No.</p>		
<p>Base Plate Retainer</p>	 <p>01 Set</p>		
<p>Cable to TD Adapter</p>	 <p>01 Set</p>		

	Hanger				
		01 No.			
BODY POWERED SHOULDER DISARTICULATION (SD) PROSTHETIC KIT					
234	SD PROSTHETIC KIT – ADULT – RIGHT	Kit Components: - Manually operated Mechanical Elbow Joint – 01 No.; Single axis Shoulder Joint – 01 No.; Mechanical Hand (VO Type)- 01 No.; Cosmetic hand gloves- 01 No.; Quick Disconnect Wrist Unit- 01 No.; Chest strap & Shoulder Harness System- with all necessary strap- 01 No.; Forearm Lift Lever Loop- 01 No.; Dual Control Cable with Cable Housing kit (with all necessary accessories - 01 No.; Extension amplifier materials – 01 No. Total Components= 09 Nos. Material: Stainless steel/ Mild Steel/ Aluminum & High Quality Fabric(Cotton/Nylon)/Leather			50 Nos.
235	SD PROSTHETIC KIT – ADULT – LEFT	Kit Components: - Manually operated Mechanical Elbow Joint – 01 No.; Single axis Shoulder Joint – 01 No.; Mechanical Hand (VO Type)- 01 No.; Cosmetic hand gloves- 01 No.; Quick Disconnect Wrist Unit- 01 No.; Chest strap & Shoulder Harness System- with all necessary strap- 01 No.; Forearm Lift Lever Loop- 01 No.; Dual Control Cable with Cable Housing kit (with all necessary accessories - 01 No.; Extension amplifier materials – 01 No. Total Components= 09 Nos. Material: Stainless steel/ Mild Steel/ Aluminum & High Quality Fabric(Cotton/Nylon)/Leather			35 Nos.
DESCRIPTION OF BODY POWERED BELOW ELBOW (BE/TR) PROSTHETIC KIT					
	Mechanical Hand (VO) with Rubberized Cover				
		01 No.			

<p>Cosmetic Glove</p>	 <p>01 No.</p>			
<p>Quick Disconnect Wrist Unit</p>	 <p>01 No.</p>			
<p>Internal locking elbow</p>	 <p>01 No.</p>			
<p>Shoulder Bulk Head joint</p>	 <p>01 No.</p>			
<p>Harness System- Figure-8- Type</p>	 <p>01 No.</p>			
<p>Dual Control Cable with housing</p>				

		01 No.			
	Base Plate Retainer	 01 Set			
	Hanger	 01 Set			
	Cable to TD adaptor	 01 No.			

ORTHOTIC COMPONENTS

CONVENTIONAL ANKLE FOOT ORTHOSIS (AFO) KIT WITHOUT SURGICAL SHOE

236	METAL ORTHOTIC AFO KIT (SIZE-1)- RIGHT SIDE	<p>Kit Components: - Side Bar Uprights – 02 Nos.; Calf Band – 01 No.; Ankle joints (Medial & Lateral) - 02 No.; Stirrup Plate= 01 No.; Stirrup Split= 02 Nos. Total Components= 08 Nos.</p> <p>Material: Uprights: - Aluminum; Joints/ Band: Stainless steel/ Mild Steel</p>	50 Nos
237	METAL ORTHOTIC AFO KIT (SIZE-1)- LEFT SIDE	<p>Kit Components: - Side Bar Uprights – 02 Nos.; Calf Band – 01 No.; Ankle joints (Medial & Lateral) - 02 No.; Stirrup Plate= 01 No.; Stirrup Split= 02 Nos. Total Components= 08 Nos.</p> <p>Material: Uprights: - Aluminum; Joints/ Band: Stainless steel/ Mild Steel</p>	50 Nos

238	METAL ORTHOTIC AFO KIT (SIZE-2)- RIGHT SIDE	Kit Components: - Side Bar Uprights – 02 Nos.; Calf Band – 01 No.; Ankle joints (Medial & Lateral) - 02 No.; Stirrup Plate= 01 No.; Stirrup Split= 02 Nos. Total Components= 08 Nos. Material: Uprights: - Aluminum; Joints/ Band: Stainless steel/ Mild Steel	50 Nos
239	METAL ORTHOTIC AFO KIT (SIZE-2)- LEFT SIDE	Kit Components: - Side Bar Uprights – 02 Nos.; Calf Band – 01 No.; Ankle joints (Medial & Lateral) - 02 No.; Stirrup Plate= 01 No.; Stirrup Split= 02 Nos. Total Components= 08 Nos. Material: Uprights: - Aluminum; Joints/ Band: Stainless steel/ Mild Steel	50 Nos
240	METAL ORTHOTIC AFO KIT (SIZE-3)- RIGHT SIDE	Kit Components: - Side Bar Uprights – 02 Nos.; Calf Band – 01 No.; Limited Motion Ankle joints (Medial & Lateral) - 02 No.; Stirrup Plate= 01 No.; Stirrup Split= 02 Nos. Total Components= 08 Nos. Material: Uprights: - Aluminum; Joints/ Band: Stainless steel/ Mild Steel	30 Nos
241	METAL ORTHOTIC AFO KIT (SIZE-3)- LEFT SIDE	Kit Components: - Side Bar Uprights – 02 Nos.; Calf Band – 01 No.; Limited Motion Ankle joints (Medial & Lateral) - 02 No.; Stirrup Plate= 01 No.; Stirrup Split= 02 Nos. Total Components= 08 Nos. Material: Uprights: - Aluminum; Joints/ Band: Stainless steel/ Mild Steel	30 Nos
DESCRIPTION OF ANKLE FOOT ORTHOSIS (AFO) ORTHOTIC KIT (SIZE – 1,2,3)			
	Stirrup Plate	01 No. 	

	Stirrup Split	02 Nos. 		
	Limited motion Ankle Joint	 02 Nos. (Medial & Lateral)		
	Uprights	 02 Nos.		
	Calf band	 01 No.		
CONVENTIONAL METAL KNEE ANKLE FOOT ORTHOSIS (KAFO) KIT WITHOUT SURGICAL SHOE				
242	METAL ORTHOTIC KAFO KIT (SIZE-1)- RIGHT SIDE	Kit Components: - Knee Lower Bar – 02 Nos.; Knee upper Bar – 02.; Drop Lock Knee Joint – 02.; Calf Band – 01 No.; Thigh Band – 01 No.; Tuber Band – 01 No.; Limited Motion Ankle joints (Medial & Lateral) - 02 No.; Stirrup Plate= 01 No.; Stirrup Split= 02 Nos. Total Components= 14 Nos. Material: Uprights: - Aluminum; Joints/ Band: Stainless steel/ Mild Steel		100 Nos

243	METAL ORTHOTIC KAFO KIT (SIZE-1)- LEFT SIDE	Kit Components: - Knee Lower Bar – 02 Nos.; Knee upper Bar – 02.; Drop Lock Knee Joint – 02.; Calf Band – 01 No.; Thigh Band – 01 No.; Tuber Band – 01 No.; Limited Motion Ankle joints (Medial & Lateral) - 02 No.; Stirrup Plate= 01 No.; Stirrup Split= 02 Nos. Total Components= 14 Nos. Material: Uprights: - Aluminum; Joints/ Band: Stainless steel/ Mild Steel	100 Nos
244	METAL ORTHOTIC KAFO KIT (SIZE-2)- RIGHT SIDE	Kit Components: - Knee Lower Bar – 02 Nos.; Knee upper Bar – 02.; Drop Lock Knee Joint – 02.; Calf Band – 01 No.; Thigh Band – 01 No.; Tuber Band – 01 No.; Limited Motion Ankle joints (Medial & Lateral) - 02 No.; Stirrup Plate= 01 No.; Stirrup Split= 02 Nos. Total Components= 14 Nos. Material: Uprights: - Aluminum; Joints/ Band: Stainless steel/ Mild Steel	100 Nos
245	METAL ORTHOTIC KAFO KIT (SIZE-2)- LEFT SIDE	Kit Components: - Knee Lower Bar – 02 Nos.; Knee upper Bar – 02.; Drop Lock Knee Joint – 02.; Calf Band – 01 No.; Thigh Band – 01 No.; Tuber Band – 01 No.; Limited Motion Ankle joints (Medial & Lateral) - 02 No.; Stirrup Plate= 01 No.; Stirrup Split= 02 Nos. Total Components= 14 Nos. Material: Uprights: - Aluminum; Joints/ Band: Stainless steel/ Mild Steel	100 Nos
246	METAL ORTHOTIC KAFO KIT (SIZE-3)- RIGHT SIDE	Kit Components: - Knee Lower Bar – 02 Nos.; Knee upper Bar – 02.; Drop Lock Knee Joint – 02.; Calf Band – 01 No.; Thigh Band – 01 No.; Tuber Band – 01 No.; Limited Motion Ankle joints (Medial & Lateral) - 02 No.; Stirrup Plate= 01 No.; Stirrup Split= 02 Nos. Total Components= 14 Nos. Material: Uprights: - Aluminum; Joints/ Band: Stainless steel/ Mild Steel	50 Nos
247	METAL ORTHOTIC KAFO KIT (SIZE-3)- LEFT SIDE	Kit Components: - Knee Lower Bar – 02 Nos.; Knee upper Bar – 02.; Drop Lock Knee Joint – 02.; Calf Band – 01 No.; Thigh Band – 01 No.; Tuber Band – 01 No.; Limited Motion Ankle joints (Medial & Lateral) - 02 No.; Stirrup Plate= 01 No.; Stirrup Split= 02 Nos. Total Components= 14 Nos. Material: Uprights: - Aluminum; Joints/ Band: Stainless steel/ Mild Steel	50 Nos



DESCRIPTION OF KNEE ANKLE FOOT ORTHOSIS (KAFO) ORTHOTIC KIT (SIZE – 1,2,3)









Stirrup Plate	01 NO.		
Split Stirrup	02 NOS.		
Limited motion Ankle Joint	02 NOS.		
Ankle uprights	02 NOS.		
Knee Lower Bar	02 NOS.		
Drop Lock Knee Joint	 02 NOS.		
Knee Upper Bar	02 NOS.		
Calf band	01 NO.		
Thigh band	01 NO.		

	Tuber Band	 01 NO.		
CONVENTIONAL METAL HIP KNEE ANKLE FOOT ORTHOSIS (HKAFO) KIT WITHOUT SURGICAL SHOE				
248	METAL ORTHOTIC HKAFO KIT (SIZE-1)- RIGHT SIDE	<p>Kit Components: - Knee Lower Bar – 02 Nos.; Knee upper Bar – 02.; Drop Lock Hip Joint with Bars – 01 No.; Drop Lock Knee Joint – 02.; Calf Band – 01 No.; Thigh Band – 01 No.; Tuber Band – 01 No.; Pelvic Band – 01 No.; Limited Motion Ankle joints (Medial & Lateral) - 02 No.; Stirrup Plate= 01 No.; Stirrup Split= 02 Nos. Total Components= 16 Nos.</p> <p>Material: Uprights: - Aluminum; Joints/ Band: Stainless steel/ Mild Steel</p>		100 Nos
249	METAL ORTHOTIC HKAFO KIT (SIZE-1)- LEFT SIDE	<p>Kit Components: - Knee Lower Bar – 02 Nos.; Knee upper Bar – 02.; Drop Lock Hip Joint with Bars – 01 No.; Drop Lock Knee Joint – 02.; Calf Band – 01 No.; Thigh Band – 01 No.; Tuber Band – 01 No.; Pelvic Band – 01 No.; Limited Motion Ankle joints (Medial & Lateral) - 02 No.; Stirrup Plate= 01 No.; Stirrup Split= 02 Nos. Total Components= 16 Nos.</p> <p>Material: Uprights: - Aluminum; Joints/ Band: Stainless steel/ Mild Steel</p>		100 Nos
250	METAL ORTHOTIC HKAFO KIT (SIZE-2)- RIGHT SIDE	<p>Kit Components: - Knee Lower Bar – 02 Nos.; Knee upper Bar – 02.; Drop Lock Hip Joint with Bars – 01 No.; Drop Lock Knee Joint – 02.; Calf Band – 01 No.; Thigh Band – 01 No.; Tuber Band – 01 No.; Pelvic Band – 01 No.; Limited Motion Ankle joints (Medial & Lateral) - 02 No.; Stirrup Plate= 01 No.; Stirrup Split= 02 Nos. Total Components= 16 Nos.</p> <p>Material: Uprights: - Aluminum; Joints/ Band: Stainless steel/ Mild Steel</p>		75 Nos
251	METAL ORTHOTIC HKAFO KIT	<p>Kit Components: - Knee Lower Bar – 02 Nos.; Knee upper Bar – 02.; Drop Lock Hip Joint with Bars – 01 No.; Drop Lock Knee Joint – 02.; Calf Band – 01 No.; Thigh Band – 01 No.; Tuber Band – 01 No.; Pelvic</p>		75 Nos

	(SIZE-2)- LEFT SIDE	<p>Band – 01 No.; Limited Motion Ankle joints (Medial & Lateral) - 02 No.; Stirrup Plate= 01 No.; Stirrup Split= 02 Nos.</p> <p>Total Components= 16 Nos.</p> <p>Material:</p> <p>Uprights: - Aluminum; Joints/ Band: Stainless steel/ Mild Steel</p>	
252	METAL ORTHOTIC HKAFO KIT (SIZE-3)- RIGHT SIDE	<p>Kit Components: - Knee Lower Bar – 02 Nos.; Knee upper Bar – 02.; Drop Lock Hip Joint with Bars – 01 No.; Drop Lock Knee Joint – 02.; Calf Band – 01 No.; Thigh Band – 01 No.; Tuber Band – 01 No.; Pelvic Band – 01 No.; Limited Motion Ankle joints (Medial & Lateral) - 02 No.; Stirrup Plate= 01 No.; Stirrup Split= 02 Nos.</p> <p>Total Components= 16 Nos.</p> <p>Material:</p> <p>Uprights: - Aluminum; Joints/ Band: Stainless steel/ Mild Steel</p>	50 Nos
253	METAL ORTHOTIC HKAFO KIT (SIZE-3)- LEFT SIDE	<p>Kit Components: - Knee Lower Bar – 02 Nos.; Knee upper Bar – 02.; Drop Lock Hip Joint with Bars – 01 No.; Drop Lock Knee Joint – 02.; Calf Band – 01 No.; Thigh Band – 01 No.; Tuber Band – 01 No.; Pelvic Band – 01 No.; Limited Motion Ankle joints (Medial & Lateral) - 02 No.; Stirrup Plate= 01 No.; Stirrup Split= 02 Nos.</p> <p>Total Components= 16 Nos.</p> <p>Material:</p> <p>Uprights: - Aluminum; Joints/ Band: Stainless steel/ Mild Steel</p>	50 Nos





DESCRIPTION OF METAL HIP KNEE ANKLE FOOT ORTHOSIS (HKAFO) ORTHOTIC KIT (SIZE – 1,2,3)

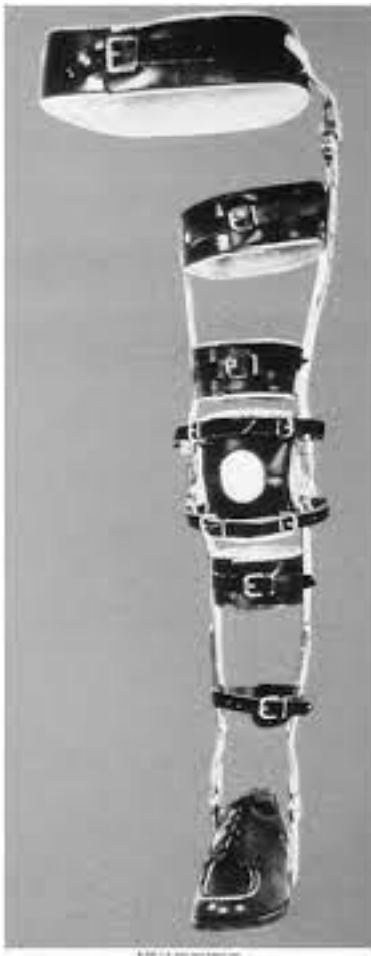





	Stirrup Plate	01 No.		
	Split Stirrup	02 Nos.		
	Limited motion Ankle Joint	02 Nos.		







Ankle uprights	02 Nos.	
Knee Lower Bar	02 Nos.	
Drop Lock Knee Joint	02 Nos.	
Knee Upper Bar	02 Nos.	
Calf band	01 No.	
Thigh band	01 No.	
Tuber Band	01 No.	
Drop Lock Hip Joint with Upright	01 No.	
Pelvic Band	01 No.	















ORTHOTIC COMPONENTS ACCESSORIES



254	Free Motion Ankle Joint with stirrup split- size I (Medial & Lateral)			50 Pairs
255	Free Motion Ankle Joint with stirrup split - size II (Medial & Lateral)			50 Pairs
256	Free Motion Ankle Joint with stirrup split- size III (Medial & Lateral)			50 Pairs
257	Limited Motion Ankle joint with stirrup split- For AFO, KAFO & HKAFO KIT Size- 1 (Medial & Lateral)			50 Pairs
258	Limited Motion Ankle joint with stirrup split- For AFO, KAFO & HKAFO KIT Size- II(Medial & Lateral)			50 Pairs

259	Limited Motion Ankle joint with stirrup split- For AFO, KAFO & HKAFO KIT Size- 1II(Medial & Lateral)			50 Pairs
260	Foot Drop Ankle joint with stirrup split- For AFO, KAFO & HKAFO KIT Size- I (Medial & Lateral)			50 Pairs
261	Foot Drop Ankle joint with stirrup split - For AFO, KAFO & HKAFO KIT Size- II(Medial & Lateral)			50 Pairs .
262	Foot Drop Ankle joint with stirrup split - For AFO, KAFO & HKAFO KIT Size- III(Medial & Lateral)			50 Pairs
263	Double Action Ankle joint with stirrup split - For AFO, KAFO & HKAFO KIT Size- 1(Medial & Lateral)			50 Pairs
264	Double Action Ankle joint with stirrup split - For AFO, KAFO & HKAFO KIT Size- 1I(Medial & Lateral)			50 Pairs
265	Double Action Ankle joint with stirrup split - For AFO, KAFO & HKAFO KIT Size- 1II(Medial & Lateral)			50 Pairs

266	Tamarack Flexure Joint –Free Motion			200 Nos.
267	Tamarack Flexure Joint Dorsiflexion Assist			100 Nos.
268	Polypropylene Oklahoma Ankle Joint-Small and Adult Size			100 Nos.
269	Drop Lock Knee Joint Size-I For Conventional KAFOs & HKAFOs			100 Nos.
270	Drop Lock Knee Joint Size-II For Conventional KAFOs & HKAFOs			100 Nos.
271	Drop Lock Knee Joint Size-III For Conventional KAFOs & HKAFOs			100 Nos.

272	Posterior Offset Knee Joint Size-I For Conventional KAFOs & HKAFOs			50 Nos.
273	Posterior Offset Knee Joint Size-II For Conventional KAFOs & HKAFOs			50 Nos.
274	Posterior Offset Knee Joint Size-II For Conventional KAFOs & HKAFOs			50 Nos.
275	Polycentric Knee Joint Size-I For Conventional KAFOs & HKAFOs			50 Nos.
276	Polycentric Knee Joint Size-II For Conventional KAFOs & HKAFOs			50 Nos.
277	Polycentric Knee Joint Size-III For Conventional KAFOs & HKAFOs			50 Nos.



278	Spring lever knee Joint Size-I For Conventional KAFOs & HKAFOs			50 Nos.
279	Spring lever knee Joint Size-II For Conventional KAFOs & HKAFOs			50 Nos.
280	Spring lever knee Joint Size-III For Conventional KAFOs & HKAFOs			50 Nos.
281	Load Response Knee Joint			20 Nos.
282	Hip Joint Drop Lock Size-I For Conventional HKAFOs			100 Nos.
283	Hip Joint Drop Lock Size-II For Conventional HKAFOs			50 Nos.



284	Hip Joint Drop Lock Size-III For Conventional HKAFOs			50 Nos.
285	Stirrup Plate- Right Size- Small, Medium & Large			100 nos.
286	Stirrup Plate- Left Size- Small, Medium & Large			100 nos.
287	Splint C/Foot with D.B. Shoe Extra Small			50 Nos.
288	Splint C/Foot with D.B. Shoe Small			50 Nos.
289	Splint C/Foot with D.B. Shoe Medium			30 Nos.
290	Milwaukee Brace- Spinal Orthosis Kits Size- Child			20 Nos.
291	Milwaukee Brace- Spinal Orthosis Kits Size- Adult			20 Nos.
292	SOMI Brace Kit- Adult Size			25 Nos.
293	Anterior Spinal Hyperextension Brace- Adult Size			25 Nos.

294	Soft Cervical Collar- Standard Size	50 Nos.
295	Rigid Cervical Collar (Philadelphia Collar)	50 Nos.
296	Porous Low temperature thermoplastic sheet- 2mm Thickness Sheet Size- 2mtr.X1 mtr. Colour- Skin tone	15 Sheets
297	Porous Low temperature thermoplastic sheet- 3mm Thickness Sheet Size- 2mtr.X1 mtr. Colour- Skin tone	15 Sheets
298	Porous Low temperature thermoplastic sheet- 4mm Thickness Sheet Size- 2mtr.X1 mtr. Colour- Skin tone	05 Sheets
299	Knee sleeve (Small, Medium, Large) (Neoprene rubberized material)	200 Nos.
300	Elbow sleeve (Small, Medium, Large)	100 Nos
301	Elastic Band (1.5 width) ; Colour- Black/ Skin Tone	100 Mtrs
302	Elastic Band (2 inches width); Colour- Black/ Skin Tone	100 Mtrs
303	Elastic Band (4 inches width); Colour- Black/ Skin Tone	100 Mtrs
304	Cosmetic Gloves with Zipper design (For Upper Limb Prosthesis) – Right Side Adult	20 Nos.

305	Cosmetic Gloves with Zipper design (For Upper Limb Prosthesis) – Left Side Adult		20 Nos.	
306	Cosmetic PU Foam Covering – Below Knee prosthesis  (Semi Rigid Foam)		100 Nos.	
307	Cosmetic PU Foam Covering – Above Knee prosthesis  (Soft Foam)		75 Nos.	
308	Dental Stone / Die Stone (Gypsum Powder)		Type-III (Physical Properties of Medium Strength). Preferably green color. (1 kg = 1 pocket)	20 Kg (20 Pockets)

309.	Dental Modelling Wax	 <p>The image shows a white box with pink and red accents labeled 'PYRAX MODELLING WAX'. Below the box is a stack of several translucent orange sheets of wax.</p>	<p>Sheet dimensions= 160mm x 90mm or 170mm x 100mm.</p> <p>Thickness = 1.0 mm to 1.5 mm</p> <p>Weight = 200 g or 500 g (1 box)</p>	10 boxes (1 box=12 pieces)
310.	Cold cure (Acrylic mixture)	 <p>The image shows two boxes of 'DPI RR Cold Cure Acrylic Repair Material'. The boxes are white with blue and teal accents. One box is labeled 'Highly Penetrating from Above 17°C' and the other is labeled 'FOR USE IN DENTISTRY'.</p>	<p>Powder: Polymethyl methacrylate (PMMA) polymer, initiator (benzoyl peroxide)</p>	2 boxes (1 box=250ml)

311.	Xylene		NA	1 bottle (1 bottle = 0.50ml)
312.	Silicone extrinsic color		Fe-1999(it includes 8 colours which, Red, Blue, Yellow, Liver Spot. C. Stipple, Stipple, Raw Sienna) from factor II.	1 box (1 box = 8 colour)

313.	Micro motor tools (different grinding and polishing tools)		<p>(12 pcs set abrasive Mounted stone for rotatory Tools Grinding Stone wheel head tools accessories)</p> <p>(Mandrel diameter = 2.1 mm)</p>	1 box (1 box = 12 pcs)
314.	Alginate impression material		<p>Dental impression material.</p> <p>(1 Pocket = ½ kg)</p>	20 kg

315.	Thixotropic agent		NA	1 Bottle (1 bottle = 200 ml)
316.	RTV Silicone Sealant		NA	2 Bottle (1 Bottle= 100 L)

317	Oven Teflon sheet		NA	5 Mtr.
318	Rexin Sheet		Thickness ranging from approximately 0.8 mm	25 Mtr.

319	Nylon webbing strap		1. Material – Nylon, 2. Width – ½” Colour - Red, Blue, White	200 Mtr. (10 rolls.) Each
320	Nylon webbing strap		1. Material – Nylon, 2. Width – ½” Colour - Red, Blue, White	200 Mtr. (10 rolls.) Each
321	Nylon webbing strap		1. Material – Nylon, 2. Width – ½” Colour - Red, Blue, White	200 Mtr. (10 rolls.) Each
322	Nylon webbing strap		1. Material – Nylon, 2. Width – ½” c) Colour - Red, Blue, White	200 Mtr. (10 rolls.) Each
323	Nylon webbing strap		1. Material – Nylon, 2. Width – ½” (a) Colour - Red, Blue, White	200 Mtr. (10 rolls.) Each

P&O Machine Equipment & Hand Tools

01.	Hot air oven	heating chamber size-36” wx24” dx30”h, with double layer toughened front visible glass with inside light arrangement, max temp.350oc12 kw rating and 1 hp3 phase motor for fan with digital timer. Thermostat temperature controller	1 No.
02.	Sand stone grinding Machine Cum polishing	Motor Power: 0.5 HP to 2 HP (for benchtop/flexible shaft), up to 7.5 HP for heavy-duty, industrial-grade machines. Operation Speed: Typically, 2800 RPM (no load) for grinding, with some units featuring variable speed (1100–7000 RPM or 1500–3000 RPM) for flexible polishing. Operating Voltage: 220V (Single Phase) or 440V (Three Phase). Disc/Wheel Diameter: 4 to 12 inches (100mm–300mm), with 6–10 inches being standard.	01 No.

03.	Infrared Oven	Dimension-600x1200x1300mm, Net weight-185 kg, Voltage-380V, 50Hz/cyc., 3-Ph, Power-2.2 kW, Speed frequency controller- 700-3000RPM, Tilt Angle Adjustable – 30 degree – 90 degree.	01 No.
04.	Bench Grinder cum sander	0.5 hp single phase motor, abrasive wheel size 10" x 1"	01 No.
05.	Pillar drilling machine	Drilling capacity 25mm, pillar dia 87mm max. distance spindle to table 600mm, table working surface dia 400mm with 1hp 3 phase motor	No.
06.	Bench drilling machine with stand	capacity ½" Hp motor	01 No.
07.	Industrial leather and canvas sewing machine	¼" HP motor	01 No.
08.	Adjustable circular saw	circular saw dia 18", working table size 24"x36", max depth of cut 5 ½" with 3hp 3 phase motor	01 No.
09.	Belt and disc sander	disc dia. 10", belt size 6"x 48" with 1 hp 3 phase motor	01 No.
10.	All-purpose saw	temperature range 100-600 degrees c, power input 2000w	01 No.
11.	Hot air gun	temperature range 100–600-degree c, power input 2000w	01 No.
12.	Jig saw machine	sawing depth in wood 54mm, rated 350w	01 No.
13.	High vacuum machine	¼" hp motor	01 No.
14.	Removable Prosthetic mandrills for Below Knee Prosthesis	Material: - Polypropylene Shape: - Conical with one side flat surface finish Size: - Handle- 8 inches with 1.5-inch diameter Body: - Length- 10 inches Maximum Diameter- 2.5 inches Minimum Diameter- 1.5 inches	03 Nos.
15.	hot water bath for softening low temperature thermoplastic sheets	Temperature Range: Adjustable between 60°C and 70°C (140°F-160°F). Approximately 18" x 24" or larger (e.g., 700 x 550 x 200 mm) Crevice-free, high-grade stainless-steel interior (SS 304)	01 No.
16.	Adjustable / fixed grinding and milling machine with dust collector	Motor: 2 Hp/ 3 Hp, Motor speed: 1400-2800 rpm, Voltage: 1.5 kw, Duct collector motor: 1.5 hp, Dust collector motor speed: 2800 rpm, Dimension: 1220x1065x760mm.	01 No.
17.	Sanding roll	Sanding roller diameter: 280mm, Polishing roller diameter: 180mm, working width: 200mm-1250mm, feeding speed: 5-40m/min, Belt size: 1330mmx2620mm, Total power: 39 kw	02 Nos.
18.	Sanding sleeve	Grit Material: Aluminum Oxide, Grit Type: Fine, Grit Number: 120 Size- 3 inches x 3 inches	02 Nos.
19.	Sanding drum	Material: Metal, Size- 3 inches diameter & 3 inches length Shank- ½ inches Solid/ Non-removable	02 Nos.
20.	Tool holder	Length 19 inches, Width – 14 inches & depth 10 inches.	05 Nos.
21.	Rasp head	<ul style="list-style-type: none"> • Head diameter: typically, 5/8 inch (approx. 15.8mm) to 30mm. • Head Length: Ranging from 1 1/8 inch (approx. 28mm) to 1 3/8 inch (approx. 35mm). • Material: Usually hardened, high-quality carbon steel or Tungsten steel. • Shank Diameter: Commonly 6mm (approx. 1/4 inch). • Shapes: Cylindrical, Conical, Ball, Flame, or Round. 	01 No.

22.	Hot sealing iron	Temperature Control: Range: 50°C to 400°C (122°F to 750°F) is common, with some industrial units going higher. Type: Constant heat (adjustable) or impulse (timed). Precision: Digital controllers for accuracy.	02 Nos.
23.	Staple gun	NA	02 Nos.
24.	Hand drill machine	Chuck size: 10 mm, Tool type: Rotary drill, Power type: Cordless, Corded, Power Voltage: 220V, Max speed: 3000 RPM, Material: Alloy	04 Nos.
25.	Cordless hand drill machine	1. Cordless Drilling machine with charger 2. Operating Voltage: 18 Volts 3. Max Screw Diameter: 10mm 4. Torque (Soft/hard): 21/54Nm 5. Minimum 1 year warranty 6. one set of drill bit 1 mm to 10 mm (1,2,3,4,5,6,7,8,9 & 10 mm) are required along with each drilling machine	02 Nos.
26.	Shoe finishing machine	Drive rotor: Electric motor, Power consumption: 50-watt, Rotational speed: 1400 rpm Input supply: single phase / 3 phase (220V, 50 Hz), Overall dimension (LxWxH): 280x370x210	01 No.
27.	Working table with pegboard	Material: Mild Steel, Size: 1500x850x800 mm (WxDxH), No. of peg: 01, Thickness on top: 34mm, No. of Drawer – 04.	10 Nos.
28.	Over locking machine	Speed: Typically, 3,000–8,500+ Stitches Per Minute (SPM), Thread: Uses 2 to 6 threads, Stitch Length: Adjustable, commonly 2 to 4 mm. Stitch Width: Varies by needle gauge (e.g., 2.0mm, 3.0mm, 5.0mm) Needle: Specific types (e.g., DCx27) and sizes (#11, #14, #18) used. Working range: 15m	01 No.
29.	Laser aligner	Working range : 15m, Levelling accuracy: Approx. 0.5mm/m, Self levelling range: Approx. 4-degree, Laser diode. Class: 635Nm<1mW/2, Power Supply: 4x1.5 V Dimension (LxWxH): 97x65x120 mm, Weight: 1.5 kg.	01 No.
30.	Interlocking machine	Needle count (2-4), thread count (4-6), <u>max speed</u> (2000-6000 stitches/min), <u>stitch length</u> (1.4-6.4mm), needle distance (3.2-6.4mm), bed type (flat, cylinder), motor (direct drive/clutch)	01 No.
31	Flat File Bastard	Material: High-quality carbon or alloy tool steel (e.g., T12 CH-Moly). Cut Type: Bastard (coarse teeth for fast cutting). Cut Pattern: Double-cut (cross-hatched) on surfaces, single-cut (straight) on edges. Shape: Flat, rectangular cross-section, tapering slightly in width and thickness towards the point. Dimensions: Available in various lengths (e.g., 200mm/8", 250mm/10", 300mm/12") and widths.	10 nos. each

32	Aluminum Flat file	<p>Material: High-quality Carbon Alloy Steel (e.g., 130 Cr2).</p> <p>Hardness: Typically, 62 HRC minimum after hardening.</p> <p>Tooth Design: Coarse, fast-cutting, single-cut teeth, specifically designed to prevent material clogging (gumming) on soft materials like aluminium.</p> <p>Dimensions:</p> <p>Length: Common sizes include 200mm, 250mm, 300mm, 350mm (file body only).</p> <p>Width: Varies; often around 25mm or more for larger files.</p> <p>Thickness: Varies by length and manufacturer.</p>	10 nos. each
33	Round file	<p>Material: Typically made from high-quality tool steel (e.g., T12 alloy) for durability and performance.</p> <p>Shape: Circular cross-section, also known as a "rat-tail" file, with a pointed or tapered end.</p> <p>Size: Defined by overall length (e.g., 200mm/8") and diameter/width of the cutting surface, often in inches or millimetres.</p> <p>Cut Type (Teeth):</p> <p>Single-cut: Parallel rows of teeth for smoother finishes.</p> <p>Double-cut (Cross-cut): Intersecting rows for faster cutting, common in coarser files.</p>	10 nos. each
34	Flat File	<p>Material: Typically made from high-quality tool steel (e.g., T12 alloy) for durability and performance.</p> <p>Shape: Circular cross-section, also known as a "rat-tail" file, with a pointed or tapered end.</p> <p>Size: Defined by overall length (e.g., 200mm/8") and diameter/width of the cutting surface, often in inches or millimetres.</p> <p>Cut Type (Teeth):</p> <p>Single-cut: Parallel rows of teeth for smoother finishes. Double (Cross-cut): Intersecting rows for faster cutting, common in coarser files</p>	10 nos. each
35	Triangular File	<ul style="list-style-type: none"> • Shape & Size: Tapering triangular cross-section, available in various lengths (e.g., 4", 6", 8", 10", 12") and corresponding widths/thicknesses (e.g., 7mm, 11mm, 14mm). • Material: High-carbon steel, hardened for durability, with softer tang for handle connection to prevent breakage. • Teeth: Different cuts available: Coarse (for rapid material removal), Medium (general purpose), Fine (smooth finish). 	10 nos. each
36	Rasp File Half round	<p>Length -6inch(150mm), Steel section: 19/32-inch x 11/64 inch (15.08x4.37mm)</p> <p>Material: Metal</p>	10 nos. each
37	Rasp File Flat	<p>Length -6inch(150mm), Steel section: 19/32-inch x 11/64 inch (15.08x4.37mm)</p> <p>Material: Metal</p>	10 nos. each
38	Rasp File Round	<p>Length -6inch(150mm), Steel section: 19/32-inch x 11/64 inch (15.08x4.37mm)</p> <p>Material: Metal</p>	10 nos. each

39	Screw driver	<p>Material: High-grade CA plastic, resistant to oil, petrol, grease, and non-flammable.</p> <p>Hardness: Tip hardness (e.g., 55-58 HRC) resists wear and bending.</p> <p>Material: High-grade Silicon-Manganese steel for spring effect and strength.</p> <p>Flathead: Width of blade * Shank length (e.g., 2mm * 75mm).</p>	10 nos. each
40	Flat Chisel	<p>Material: High-grade carbon steel or Chrome Vanadium steel</p> <p>Cutting Edge: Harder (e.g., 55-57 HRC)</p> <p>Overall Length: Varies (e.g., 150mm, 200mm, 400mm).</p>	02 nos. each
41	Cold chisel	<p>Material: High-quality alloy steel or chrome vanadium steel</p> <p>Cutting Angle: Usually 50-60 degrees (included angle)</p> <p>Dimensions: Vary widely; common sizes include blade widths from 6mm (1/4") to 35mm (1"+) and lengths from 100mm (4") to 300mm (12")</p>	02 nos. each
42	Half round chisel	<p>Material: High-carbon steel, Chrome Vanadium (Cr-V) steel, or Chromium-Molybdenum steel</p> <p>Cutting Edge: Shaped to a half-circle; width/diameter varies (e.g., 10mm, 13mm, 1/4", 32mm).</p> <p>Length: Varies, from ~100mm (short cold chisels) to 150-250mm for longer versions.</p>	02 nos. each
43	Ruler steel	Length- 1600mm, Width- 300mm	02 nos. each
44	Steel square with leg/ Tri- Square	<p>Material- Arm & Body- Carbon Steel, Cast Zinc Handle, Metric/Imperial Marking on ruler,</p> <p>Blade Length- 12 inches, Handle- 7 1/4 Inches</p>	02 nos. each
45	Spring Caliper inside	Material- Stainless Steel. Size- 12 Inches	02 nos. each
46	Caliper outside	Material- Stainless Steel. Size- 12 Inches	02 nos. each
47	Compass/ Driver	<p>Material: Metal (steel, zinc alloy) or plastic for durability and precision.</p> <p>Size/Range: Varies from small (4-8 inches) to large (up to 24 inches or more)</p>	02 nos. each
48	Hammer ball pein	<p>Head Material: High-grade Carbon Steel, Drop Forged, Induction Hardened.</p> <p>Head Hardness: Typically, 50-58 HRC. Head weight: 8oz/220 g</p>	10 nos. each
49	Mallet Hammer	<p>Head Material: Rubber, plastic (HDPE, nylon), wood (hickory, oak), brass, copper, or composite.</p> <p>Weight: Ranges from light (250g) for detail work to heavy for assembly (e.g., 450g, 1.4kg).</p> <p>Handle: Wood (classic), fiberglass (durability), steel (strength), or composite, often with ergonomic grips.</p> <p>Face Diameter/Size: Indicates the striking surface (e.g., 35mm, 50mm).</p>	02 Nos. Each
50	Hammer seaming plier (pincer)	<p>Length: Commonly 8 inches to 9 inches (approx. 200–225mm).</p> <p>Jaw Width: 3 inches (approx. 80mm) is standard, with 6-inch (150mm) options for wider applications.</p> <p>Depth: Throat/seaming depth often ranges between 30mm and 60mm.</p>	04 nos. each
51	Nipper	Material: High-grade alloy steel, high carbon steel, often heat-treated or induction-hardened for durability.	02 nos. each

		Size/Length: Typically compact, around 115mm to 120mm (4.75 inches)	
52	Plier	Steel Type: High-grade carbon steel for strength. Overall Length: Total length (e.g., 150mm, 200mm).	10 nos. each
53	Long nose plier	Material: High-grade steel, often <u>Chrome Vanadium (Cr-V)</u> for durability, with anti-rust finish like black phosphate or nickel plating. Length: Varies (e.g., 6-inch, 8-inch, 200mm), with longer for deeper reach.	10 nos. each
54	Revolving Hole punch	Metric: Common sizes include 2mm, 2.5mm, 3mm, 3.5mm, 4mm, 4.5mm, 5mm. Imperial (Inches): Often fractional, like 5/64", 3/32", 7/64", 1/8", 5/32", 3/16". Number of Sizes: Typically 6 to 8 different sizes on the revolving head. Material: High-grade alloy or chrome steel, heat-treated for sharp, durable cutting blades	10 nos. each
55	Centre punch	Material: Hardened & Tempered Alloy/Tool Steel Dimensions: Vary by tool, common examples: 100mm length, 10mm body diameter, 4-8mm tip diameter.	10 nos. each
56	Hole Punch	Alloy steel material with imperial sizes (in inches)	03 nos. each
57	Hole Punch set	Alloy steel material with imperial sizes (in inches)	02 nos. each
58	Scissor	Material: High Carbon Steel, Stainless Steel (German, etc.), Polypropylene (handles). Dimensions: Total Length (e.g., 160mm, 180mm, 6-7 inches), Blade Length (e.g., 40mm, 66mm, 4.5-8 inches), Blade Thickness (e.g., 2.5mm).	10 nos. each
59	Hacksaw Frame	<u>Adjustable Flat</u> : Versatile for different standard lengths (e.g., 250-300mm). <u>Adjustable Tubular</u> : lengths (e.g., 250-300mm). Blade Capacity: Usually specified by the blade length it holds (e.g., 300mm/12") or the range (e.g., 250-300mm). Material: Steel (heavy duty), aluminum (die-cast for lightness), or steel with plastic/rubber handles.	10 nos. each
60	Hacksaw blades	Blade Capacity: Usually specified by the blade length it holds (e.g., 300mm/12") or the range (e.g., 250-300mm).	144 pcs
61	Tap Handle	Length: 8" (200 mm) Jaw Holding Capacity (Square Size): 3/32" - 1/2" (2.5 mm - 9.5 mm) Jaw Holding Capacity (Tap Size) Inch: 1/8 - 3/8 Jaw Holding Capacity (Tap Size) mm	02 nos. each
62	Grip Plier	Length: Commonly 8 inches to 9 inches (approx. 200–225mm). Jaw Width: 3 inches (approx. 80mm) is standard, with 6-inch (150mm) options for wider applications. Depth: Throat/seaming depth often ranges between 30mm and 60mm.	02 nos. each
63	Dieset	<u>Material & Finish</u> : Steel, hardened steel, etc., and surface finish (e.g., roughness) for plunger/anvil surfaces.	10 nos. each

		Application-Specific: For <u>XRF Pellet Dies</u> , specifications include plunger height and anvil height; for <u>Pipe Threading</u> , it's pipe size and thread type (e.g., NPT). Tap & Die Sets (for threading): Thread size (e.g., M3 x 0.5, M10 x 1.5), thread pitch (coarse/fine), material (carbon steel), and included accessories (wrenches, holders)	
64	Cros pein hammer	Head Material: Typically high-quality drop-forged steel, often hardened for durability. Handle Material: Commonly seasoned wood (like hickory) for grip and shock absorption, though synthetic materials (polypropylene, fiberglass) are also used. Weight: Varies significantly, from light-duty (200g, 0.44 lbs) to heavier types (800g, ~1.76 lbs).	10 nos. each
65	Wire cutter	Material- Metal, Size- 8 inches	10 nos. each
66	Measuring tape	Tailoring measuring tape length: 1 meter.	10 nos. each
67	Shoe maker hammer	Material: Head forged from high-hardness steel Weight: Varies by preference, typically 7.5 oz (210g) to 13 oz (370g) or more, for balanced use. Length: Around 12 to 14 inches (30-35 cm) for good leverage and control.	05 nos. each
68	Anvil	Material: Hardened tool steel (preferred), cast iron (basic/soft). Weight: 75 to 500+ lbs	02 nos. each
69	Half round leather knife (Rapi)	Metal grade - steel W1-7(60-62 HRC) Metal thickness - 3mm Coverage - linseed oil; Handle material -oak. 180 degree cutting edge!	05 nos. each
70	Nipper Shoemaker	Material: High-grade forged alloy steel, stainless steel. Length: Commonly around 4 inches (100mm) for fine work, or up to 12-14 inches	05 nos. each
71	Leather Knife	Wooden Handle Leather Working Knife, Material: high-quality steel with wooden handle.,Length: approx. 6.7 inch; Knife Head Size: 3.5cm x 7cm (1.38"x 2.75"),Blade Material- Alloy Steel, Blade Length- 4 Inches	02 nos. each
72	Bender brace	Weight: 978 g Material- Hardened Mild steel	1 no. each
73	Cone sander fine, Medium, coarse	Material: Usually made from high-standard steel, with some being forged from 1018 steel or plasma-cut from AR500 steel. Hardy Shank: Designed to fit standard 1-inch (or sometimes 3/4-inch) hardy holes. Gap Between Tines: Typically around 1 inch to 1-1/4 inches. Total Length: Generally, around 6 to 7 inches.	10 nos. each
74	Plaster knife	Material- Stainless steel, Weight – Approx. 170 g	10 nos. each

75	Vice limb Maker	Material- Wood Size- 12 inches x 18 inches Jaw Opening- 10 inches	1 no. each
76	Bending fork	Material- Hardened Cast Iron Shank Length- 10 inches Jaw Length- 2 inches Jaw width- 4mm and 6mm	02 nos. each
77	Caliper AP /Measurement	Material- High Grade Wood Dimension- 19.3 x 3.8 x 61.5 cm	02 nos. each
78	Ear Protector/ Over-the Head Ear Muffs	<ul style="list-style-type: none"> • Noise Reduction (NRR 26dB / SNR 33dB): Double-shell insulation and oval foam padding block harmful noise levels, providing reliable protection in loud environments. • Soft padded headband with 4-point suspension Stainless steel wire headband	05 nos. each
79	Heat Proof Gloves/ Kevlar heat resistant glove	<ul style="list-style-type: none"> • Material- The Gloves are made from 1.5mm thick and soft shoulder split natural leather • Size- Adult (14 Inches) [The 14 inches extra-long glove with 7.5 inches long sleeve • Heat Temperature- Up to 400 degrees Celsius. • Reinforced Double Layer Kevlar Padding on Finger, Palm Back Design- Outermost layer: Double layer kevlar padding leather. Intermediate layer: a composite product by laminating a kind of high temperature resistant Genuine Quality Split Leather in Lower Half and a flame-retardant cotton cloth. Inner layer: a 100% soft insulated cotton lining.	04 Pairs
80	Eyelet punch	Pliers Size: 20cm (7., 9 inches) Eyelet Size: 4., 8mm (outer diameter), 4., 5mm (inner diameter) Material: Steel with anti-rust coating Included: 1x punch plier, 100x gold eyelets	10 nos. each
81	Rivet head finishing punch	Rivet Diameter Compatibility: Commonly available for rivet diameters of 2 mm, 3 mm, 4 mm, 5 mm, and 6 mm (or fractional equivalents like 1/8", 3/16", 1/4"). Material: Usually made from hardened alloy tool steel	10 nos. each
82	Allen Keys set	9 Pcs. Set (1.5mm, 2mm, 2.5mm, 3mm, 4mm, 5mm, 6mm, 8mm,10mm)	10 Sets. each
83	Torque Wrench	<ul style="list-style-type: none"> • Material- Made from high grade steel • Three-way signal-touch, sight and sound. • Push through moveable square permits use on both right hand and left-hand directions. Size range- 3/8'' to 1'' diameter x 2-10 to 400-1000 LBFT x 0.3-1.4 to 55-140 KGF.M x 3-14 to 540-1380 NM	01 no.
84	Bench Vice	Jaw Width (Size): The primary size indicator, e.g., 4", 6", 8" (100mm, 150mm, 200mm). Jaw Opening : Max distance the jaws can separate.	10 nos. each

		<p>Throat Depth: Distance from the screw to the fixed jaw, affecting workpiece clearance.</p> <p>Material: Body: Cast Iron (basic), Ductile Iron (stronger, less brittle), or All Steel (heavy-duty). Jaws: Hardened & serrated carbon/alloy steel</p>	
85	Vernier Caliper	<p>Range (Measuring Capacity): The maximum length the caliper can measure, commonly 0-150mm (6") or 0-200mm (8"), but can go up to 1000mm or more.</p> <p>Least Count (Resolution): The smallest measurement increment, typically 0.02mm (metric) or 0.001" (inch) for standard models, with higher precision possible.</p> <p>Accuracy: The maximum permissible error, usually ± 0.02mm to ± 0.05mm for common sizes, depending on the range and quality.</p> <p>Material: Usually hardened stainless steel for durability, often with satin chrome finish for readability.</p>	10 nos. each
86	V- Block	<p>Hardened Steel V Block Set with Clamp 90 Degree Angle 1-5/8" x 1-1/4" x 1-1/4" Inch (40 x 32 x 32 mm) II Multi-use Gauge Gage Machinist Tool</p> <ul style="list-style-type: none"> • Precision Vee Block for Grinding, Milling or Drilling Job. • The sides are parallel and Vee is ground. • 1-5/8" x 1-1/4" x 1-1/4" Inch (40 x 32 x 32 mm) • Holding capacity - 1" Inch I 25 mm Capacity 	02 nos. each

Important Note:

The vendors may be asked to produce sample of quoted materials to qualify technically during technical evaluation process. Non production of sample will resulting in rejection of said material technically. Financially qualified bidders will be submitting one set of each qualified item as sample to NIEPMD for entire currency of contract. No cost will be paid for Samples; samples will be returned to supplier on closing of contract.

Special Terms & Conditions:

1. The bidder should have their own agency facility. Proof to be uploaded with the Tech Bid.
2. The bidder should have an average annual minimum turnover of **Rs. 50 Lakh** for last 03 financial years (i.e. at least Rs. 1.5 crores during last 03 FYs.). Proof of certificate for turnover is required to be uploaded with the tender (CA attested copy of the balance sheet with profit & loss statement of last 03 FYs. i.e. 31st Mar 2025)
3. The applying firm must be registered with the GSTIN and the supporting proof for the same is to be uploaded.
4. Tenderer should upload for last 03 FYs income tax return copies ending on 31st March 2025.
5. The bidder must have minimum 03 years' experience in present business, proof of 03 years' experience and in businesses should be uploaded with technical bid. Bidders should provide brief profile of their work experience for the last three years along with the relevant samples of the similar work done earlier.
6. Must have minimum 03 years' experience in the field of supplying **Prosthetics & Orthotics (P&O) Components & Raw Materials** to any government agency / PSU/ autonomous bodies. Proof of experience in form of supply orders / delivery challans / contract awarding letter may be uploaded.
7. The materials should be delivered at NIEPMD, Chennai and its Composite Regional Centers (CRCs). Transportation charges in the cheapest mode (Until otherwise instructed) will be paid on production of original transportation invoices.
8. **The total cost quoted should be exclusive of taxes. Applicable taxes to be mentioned separately. Tax applicable at the time of invoice will be paid.**
9. NIEPMD reserves the right to accept / reject / select more than one Agency. And to annul the bidding process of any or all bids at any time prior to award of contract without thereby incurring any liability to the affected bidders.
10. Product images uploaded in scope of work are for reference purpose only, however tender document does not recommend for any specific brand/make/ manufacturer. In case if any seems to be like this it will be a co-incident only.
11. In case of any query / clarification regarding items technical specification please contact on mobile No. 8072267210.
12. **The successful bidder will be required to execute a performance security of 10% (ten percent) of the value of the contract in form of fixed Deposit with bank with lien made until the contract is over or one year, whichever is later.**
13. In case of not depositing or showing inefficiency to deposit the performance security after successfully qualifying, the proposal will be treated as cancelled.

We agree to all terms and conditions as mentioned above including the validity of the offer.

Utmost confidentiality of the data provided shall be maintained.

Name, Designation & Signature of the bidder with the seal

CHECK LIST

The Technical Bid shall be summarily rejected, if these documents are not uploaded.

Documents must be attached in following serial order only.

Sl. No.	Particulars	Yes / No
1.	EMD Amount of Rs.50,000/- (receipts of online payment be uploaded with technical bid)	
2.	Proof of average annual turnover of last 03 financial years Rs. 50/-Lac (I.e. 1.5 Crores in 03 FYs) (CA certified copies and profit and loss statement with balance sheet to be uploaded with technical bid)	
3.	Copy of appropriate PAN Card (be uploaded with technical bid)	
4.	Copy of GSTIN Certificate (GSTIN should be active mode)	
5.	Technical Specification of materials quoted in respect to our tender document. (Serial No. & Name of Item, Page No.) as per appendix "B"	
6.	Undertaking to supply on credit of 30 days after clear receipt of materials (be uploaded with technical bid)	
7.	Proof of having own agency facility. (Proof to be uploaded)	
8.	Copies of supply orders / challans / contract award letter of authentic agencies as proof of in same business.	
9.	Self-certification that firm is not blacklisted / debarred during last 03 years.	
10.	Undertaking regarding rates will be firm during contract period. (Self-Certificate on company letter head to be uploaded)	
11.	Copy of Income Tax Return of the firm/company/agency (Individual in case sole proprietary firm) for last 03 financial years. (Ending 31 st March 2025).	
12.	Copy of NIT duly signed and stamped by the bidder on all pages Must be uploaded.	
13.	The Bidder must either be the Original Equipment Manufacturer (OEM) or an authorized dealer. In case of OEM, Proof of being Original Equipment Manufacturer (OEM) or authorized dealer must be uploaded OR In case of authorized representative of OEM - current authorization from the OEM must be uploaded. OR In case of Authorised distributor of OEM detailed and valid agreement between Distributor and the OEM(s) defining clearly the role, responsibility, scope of work and contribution towards the tendered Equipment/System for each OEM(s).must be uploaded.	
14.	Agreed with Important note on page No. 80 regarding providing samples of quoted materials	
15.	Conditions mentioned in Important Note on Tender Page No. 83 must be adhered and document must be uploaded as per mentioned terms.	

Important Note:

- a) All the certificate and undertaking required in tender document must be signed and mentioned with date on or after the tender release date.
- b) Any Certificate submitted without signature, without date or old date will not be considered for evaluation purpose.
- c) Where the certificates are having valid up status, the certificate expiry date should be after the last date of tender opening date.
- d) Any document uploaded with technical bid must be clear and in readable condition, hazy document or document in not readable condition will not be considered for evaluation. Institute will not borne any responsibility in this regard.

**NATIONAL INSTITUTE FOR EMPOWERMENT OF PERSONS
WITH MULTIPLE DISABILITIES (NIEPMD)**

(Department of Empowerment of Persons with Disabilities,
Ministry of Social Justice & Empowerment, Govt. of India)

East coast Road, Muttukadu, Kovalam(post) Chennai-603 112

Tel:044-27472113,274720 46 Fax:044-27472389

www.niepmd.nic.in Email:niepmd@gov.in

FINANCIAL BID

(b) BOQ in excel format provided with tender document should be downloaded and filled up as per details in BOQ document. No commercial quote should be mentioned in technical bid. In case mentioning commercial quotes with technical bid will leads in rejection of tender document.

Signature and seal of the bidder

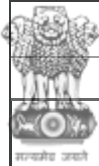

Basic Details

Organisation Chain	National Institute for Empowerment of Persons with Multiple Disabilities		
Tender Reference Number	NIEPMD/Pur 4 (13)/2025-26		
Tender ID	2026_NIEPM_895512_2	Withdrawal Allowed	Yes
Tender Type	Open Tender	Form of contract	Item Rate
Tender Category	Goods	No. of Covers	2
General Technical Evaluation Allowed	No	ItemWise Technical Evaluation Allowed	Yes
Payment Mode	Offline	Is Multi Currency Allowed For BOQ	No
Is Multi Currency Allowed For Fee	No	Allow Two Stage Bidding	No

Payment Instruments

Offline	S.No	Instrument Type
	1	R-T-G-S
	2	NEFT

Cover Details, No. Of Covers - 2

Cover No	Cover	Document Type	Description
1	Fee/PreQual/Technical	.pdf	Technical Bid
2	Finance	.xls	BOQ

Other Important Documents

S.No	Category	Sub Category	Sub Category Description	Format/File
1	Certificate Details	Permanent Account Number	Permanent Account Number Details	
2	Certificate Details	Registration Certificate	Registration Certificate Details	
3	Certificate Details	Income Tax Certificate	Income Tax Certificate Details	
4	Certificate Details	GST Registration Certificate	GST Registration Certificate	
5	Certificate Details	The Micro, Small and Medium Enterprises Certificate	The Micro, Small and Medium Enterprises Certificate	
6	Financial Details	Annual Turn Over Details	Annual Turn Over Details	
7	Financial Details	Annual Turn over certificates from CA	Annual Turn over certificates from CA	
8	Financial Details	Audited Profit and Loss Account and Balance Sheet Details for last 3 Years	Audited Profit and Loss Account and Balance Sheet Details for last 3 Years	
9	Purchase Order Details	Purchase Orders - 1	Purchase Orders - 1	
10	Purchase Order Details	Purchase Orders - 2	Purchase Orders - 2	
11	Purchase Order Details	Purchase Orders - 3	Purchase Orders - 3	
12	Purchase Order Details	Purchase Orders - 4	Purchase Orders - 4	
13	Purchase Order Details	Purchase Orders - 5	Purchase Orders - 5	

Tender Fee Details, [Total Fee in ₹ * - 0.00]

Tender Fee in ₹	0.00		
Fee Payable To	Nil	Fee Payable At	Nil
Tender Fee Exemption Allowed	No		

EMD Fee Details

EMD Amount in ₹	50,000	EMD Exemption Allowed	Yes
EMD Fee Type	fixed	EMD Percentage	NA
EMD Payable To	Director, NIEPMD	EMD Payable At	Chennai

[Click to view modification history](#)

Work /Item(s)

Title	Purchase of Prosthetics and Orthotics Components Kits Raw Materials and Machinery Equipment		
Work Description	Purchase of Prosthetics and Orthotics Components Kits Raw Materials and Machinery Equipment		
Pre Qualification Details	As per NIT Document		
Independent External Monitor/Remarks	NIEPMD Purchase Committee		
Show Tender Value in Public Domain	No		

Tender Value in ₹	0.00	Product Category	Consumables-Raw materials	Sub category	Purchase of Prosthetics and Orthotics Components
Contract Type	Rate Contract	Bid Validity(Days)	60	Period Of Work(Days)	1095
Location	NIEPMD, ECR, Muttukadu, Kovalam, Chennai	Pincode	603112	Pre Bid Meeting Place	NA
Pre Bid Meeting Address	NA	Pre Bid Meeting Date	NA	Bid Opening Place	NIEPMD, ECR, Muttukadu
Should Allow NDA Tender	No	Allow Preferential Bidder	No		

Critical Dates

Publish Date	13-Apr-2026 02:00 PM	Bid Opening Date	05-May-2026 04:30 PM
Document Download / Sale Start Date	13-Apr-2026 02:00 PM	Document Download / Sale End Date	04-May-2026 04:00 PM
Clarification Start Date	13-Apr-2026 02:00 PM	Clarification End Date	04-May-2026 04:00 PM
Bid Submission Start Date	13-Apr-2026 02:00 PM	Bid Submission End Date	04-May-2026 04:00 PM

Tender Documents

NIT Document	S.No	Document Name	Description	Document Size (in KB)
	1	Tendernotice_1.pdf	NIT Document	2695.51

Work Item Documents	S.No	Document Type	Document Name	Description	Document Size (in KB)
	1	BOQ	BOQ_951531.xls	BOQ	796.00

Bid Openers List

S.No	Bid Opener Login Id	Bid Opener Name	Certificate Name
1.	kmrajesh2002@gmail.com	M Rajesh	RAJESH MUNIYANDI
2.	kanchana70_ravi@yahoo.co.in	J Kanchana	J KANCHANA
3.	prabhakant997@gmail.com	Prabha Kant Tripathi	PRABHA KANT TRIPATHI

GeMARPTS Details

GeMARPTS ID	VSP2OUZ5CJIF
Description	P and O New
Report Initiated On	13-Apr-2026
Valid Until	13-May-2026

Tender Properties

Auto Tendering Process allowed	No	Show Technical bid status	Yes
Show Finance bid status	Yes	Stage to disclose Bid Details in Public Domain	Technical Bid Opening
BoQ Comparative Chart model	Normal	BoQ Compative chart decimal places	2
BoQ Comparative Chart Rank Type	L	Form Based BoQ	No

TIA Undertaking

S.No	Undertaking to Order	Tender complying with Order	Reason for non compliance of Order
1	PPP-MII Order 2017	Agree	Agree
2	MSEs Order 2012	Agree	Agree

Tender Inviting Authority

Name	Director, NIEPMD
Address	ECR, Muttukadu, Kovalam Post Chennai -603112

Tender Creator Details	
Created By	Prabha Kant Tripathi
Designation	Asst. Store and Purchase Officer
Created Date	13-Apr-2026 12:41 PM