



# Development of thermally insulated vending cart for fresh fruits and vegetables

**Prof. Abhijit P Deshpande**

**Sreenivas Chigullapalli**

**Hisham K V**

**RuTAG IIT Madras**



# Vegetable & fruit vending in India

- Street vending is a global phenomenon and the most visible aspect of the informal sector in India
- Like other informal sector, street vending is characterized by
  - low level of income
  - ease of entry
  - self-employment
- Vending involves enormous physical labour; **arranging, cleaning, sorting, weighing and dealing with customers** is not easy
- Hawkers are **on the move from one lane to another** irrespective of the heat, wind, rain and cold.



# Main problem to be addressed

- Local vendors would procure fresh produces in small quantity and display on the wooden/metal platform of a Pulling Vending Cycle and then move around the residential areas. As a result,
  - these **fresh vegetables and fruits are always exposed to sunlight, heat, dust, rain** etc. which leads to most unhygienic condition of these fresh food items
  - the fresh vegetables and fruits being perishable in nature are **either rotten or wilted within few hours**
  - **the leafy vegetables are curled due to heat and rotten due to the presence of sprinkled water** and thus, the products become unacceptable by the customers
- In such case, the vendor has to either discard or throw the rotten vegetables or sell the goods at low price
  - discarding the fresh produces on regular basis leads to great financial loss to the poor vendor due to spoilage of perishable commodity goods with limited shelf life.



## Who has this problem, how many people are affected, where does it occur?

- Mobile street vendors/hawkers who sell vegetables and fresh fruits at the consumer doorstep or at any designated locations face problems to keep the vegetables/fruits fresh during the daily operations.
- There are no statistics related to the vegetable/fruit vendors due to their unorganized nature of operations.
- The problem occurs and very common at places where there is a mismatch of supply and demand at retail markets.
- A number of urban poor are involved in vending in poor living conditions as their income is insufficient due to the loss of quality of their produce.



# Why is it a priority to solve this?

- India is the second largest producer of fruits and vegetables in the world after China (2015-16)
  - 90 MT fruits
  - 169 MT vegetables(2015-16)
- As per latest estimates by the Associated Chambers of Commerce of India, a country-wide study measuring crop losses revealed that **5.8%-18.1% fruits**, and **6.9%-13% vegetables** were **lost during harvesting, post-harvest activities, handling and storage**
- Post-harvest losses in India stem from a range of factors including
  - **lack of post-harvest infrastructure**
  - **value chain riddled with inefficiencies**
  - imperfect market knowledge, and
  - inadequate market access.
- India currently *leads the world in producing a wide range of agricultural commodities* and **yet, faces the threat of food and nutrition insecurity**. According to the 2014 Global Hunger Index, India ranks 55 among 120 countries with the highest food insecurity.



# Problem to be solved

- To reduce the spoilage of vegetables and fresh fruits during the retail marketing by street vendors thereby offsetting a fraction of post-harvest losses in the supply chain
- To increase the shelf life of fresh fruits and vegetables during the retailing/street vending so that consumers can get more utility for their spending

# How is the problem currently being solved?

- Street vendors use wet gunny bags and sprinkle water on their produce to keep it fresh. This leads to spoilage of the vegetables, particularly the leafy ones and tomatoes, cucumber, etc. as these vegetables have a short shelf life.





# Why would they (customers) pay for the proposed solution/product/service?

- Street vendors would be able to pay for the solution because they would be able to reduce the spoilage of vegetables/fruits in the retail operations with increased shelf life with refrigerated/thermally insulated vending cart.
- Few field observations are required to estimate the current practices and losses incurred by the street vendors.



# Review of status: Any existing/ past initiatives to solve this issue? (...1)

- Many organizations have tried developing new and innovative designs of vegetable and fruit vending carts, which are listed below:
  - Safal by Mother Dairy fruit and vegetable Pvt. Ltd.
  - Solar vegetable cart by Indian Agricultural Research Institute (IARI)
  - Samriddhii vending cart by Sampoon Samriddhii
  - Vegetable vending van by ICAR-IIHR (Indian Council of Agricultural Research and Indian Institute of Horticulture Research)



*Samriddhii motorized vegetable vending cart*



*Solar vending cart*



*Samriddhii vegetable vending cart*



*Safal vegetable vending cart*



*Rickshaw mounted vegetable vending cart*



*Innovative Designs of Thermal insulated Vending Cart developed earlier*



## Review of status: Any existing/ past initiatives to solve this issue? (...2)

- All these above mentioned designs are made with cycle rickshaw pulling mechanism which may not be accepted by the vendors as they are not habitual to this mechanism.
- Instead, the design has to be made as per the existing mechanism with similar convenient features to the vendor.
- Currently available vegetable vending carts priced in between **Rs.30,000 – 50,000 per unit**, depending upon the capacity and design.
- The vendors may not be able to afford the investment required for complete shift from conventional vending carts to the new ones. So, in this proposal a possible retrofit for vegetable vending cart is envisaged.



## Suggested/proposed solution provided in project

- To design thermal insulated rotational moulded plastic based compartment design with transparent cover for display of fruits and vegetables by maintaining the temperature of 15-25 degree C to keep the freshness of fresh produces and a Canopy to protect the product/vendor from rain and sun will be designed as an attachment which can be easily bolted over the existing wooden platform of vending cycle.
- The vendor need not to purchase a new vending cart. Rather, only the upper moulded part with thermal insulation can be procured as an attachment. This will definitely reduce the cost of the vending cycle.
- Expected solution should be affordable to the street vendors and possibly below Rs. 20,000.

# Conceptual designs made by RuTAG IIT Madras

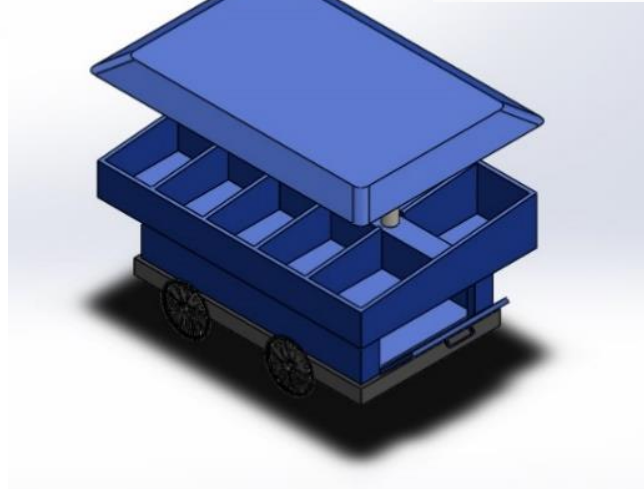
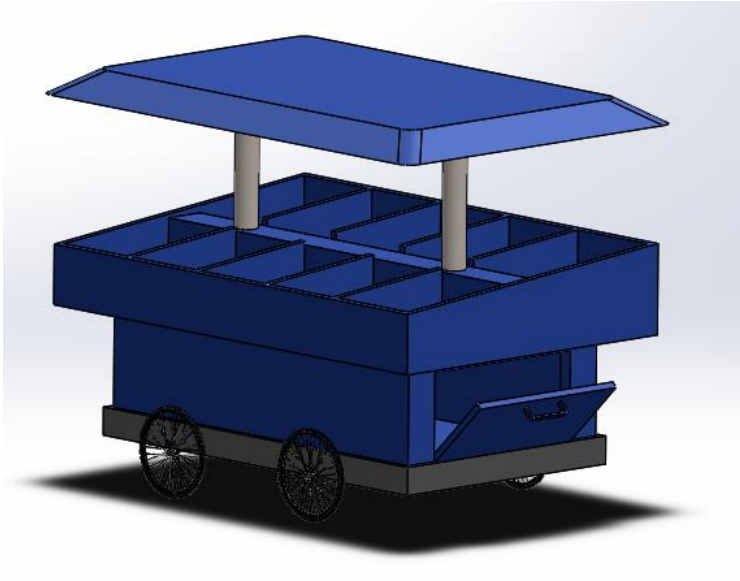



# Methodology

- The proposed project may involve the following tasks and sub-tasks:
  - Design modification in current vending cart / design of new vending cart
    - ✓ Analysis of available design alternatives
    - ✓ Choosing suitable alternative and preparing engineering design drawing
  - Fabrication of prototype & testing
  - Field trials and feedback



# Nature of project

- Scientific knowledge generation for future use in product/ process development
- Development of new technology (only design)
- Modification/ upgradation of existing technology (only design)
- Fabrication of prototype/ Lab scale testing (may include field trials to get inputs)
- Pilot study/ Demonstration of final deliverable on field



# Target beneficiaries

- Farmers
- Women
- Youth (unemployed, unskilled/semi-skilled)
- Economically weaker sections
- Others: Mobile Street Vendors

# Expected benefits

Nature of benefits	Brief description
Drudgery reduction/ Ease of operation	Due to the reduced spoilage, vendors may have to invest little time in sorting out the damaged vegetables/fruits from the stock in the cart.
Improved livelihood opportunities	With reduced financial losses in retail operations, street vending of vegetables/fruits may be a lucrative business opportunity, especially for women in urban/semi-urban localities.
Value addition	Due to increased shelf life of the vegetables and fruits, street vendors would be able to fetch better market prices under volatile market supply demand scenario.



# Budget details

Sr. no	Item	Estimated Budget (Rs. in lakhs)
<b>A</b>	<b>Recurring</b>	
	Manpower	---
	Consumables	0.5
	Travel	0.5
	Demo/ Field Trials	2.0
	Contingencies	0.5
<b>B</b>	<b>Non- recurring</b>	
	Permanent equipment	---
	Fabrication of prototype (5 units)	1.5
<b>C</b>	<b>Institute Overhead</b>	1.0
	<b>Grand total (A+B+C)</b>	<b>6.0</b>



**Thank you**